

N72-19991

NASA TECHNICAL
MEMORANDUM

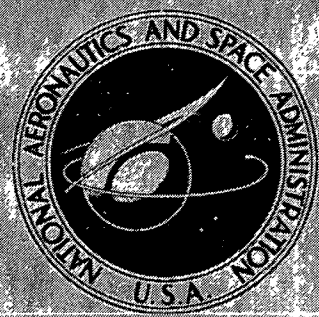

NASA TM X-2448

NASA TM X-2448

CASE FILE
COPY

PERFORMANCE OF
A 1380-FOOT-PER-SECOND-TIP-SPEED
AXIAL-FLOW COMPRESSOR ROTOR WITH
A BLADE TIP SOLIDITY OF 1.3

by Roy D. Hager, David C. Janetzke, and Lonnie Reid
Lewis Research Center
Cleveland, Ohio 44135

1. Report No. NASA TM X-2448	2. Government Accession No.	3. Recipient's Catalog No.	
4. Title and Subtitle PERFORMANCE OF A 1380-FOOT-PER-SECOND-TIP-SPEED AXIAL-FLOW COMPRESSOR ROTOR WITH A BLADE TIP SOLIDITY OF 1.3		5. Report Date April 1972	6. Performing Organization Code
		8. Performing Organization Report No. E-6503	10. Work Unit No. 764-74
7. Author(s) Roy D. Hager, David C. Janetzke, and Lonnie Reid		11. Contract or Grant No.	
9. Performing Organization Name and Address Lewis Research Center National Aeronautics and Space Administration Cleveland, Ohio 44135		13. Type of Report and Period Covered Technical Memorandum	
		14. Sponsoring Agency Code	
12. Sponsoring Agency Name and Address National Aeronautics and Space Administration Washington, D. C. 20546		15. Supplementary Notes	
16. Abstract This report presents the aerodynamic design parameters, along with the overall and blade element performance, of an axial-flow compressor rotor designed to study the effects of blade solidity on efficiency and stall margin. At design speed the peak efficiency was 0.844 and occurred at an equivalent weight flow of 63.5 lb/sec with a total pressure ratio of 1.801. Design efficiency, pressure ratio, and weight flow were 0.814, 1.65, and 65.3 (41.1 lb/sec/sq ft of annulus area), respectively. Stall margin for design speed was 6.4 percent based on the weight flow and pressure ratio values at peak efficiency and just prior to stall.			
17. Key Words (Suggested by Author(s)) Compressor Axial flow Turbomachinery		18. Distribution Statement Unclassified - unlimited	
19. Security Classif. (of this report) Unclassified	20. Security Classif. (of this page) Unclassified	21. No. of Pages 94	22. Price* \$3.00

PERFORMANCE OF A 1380-FOOT-PER-SECOND-TIP-SPEED AXIAL-FLOW
COMPRESSOR ROTOR WITH A BLADE TIP SOLIDITY OF 1.3

by Roy D. Hager, David C. Janetzke, and Lonnie Reid

Lewis Research Center

SUMMARY

The overall performance and the blade element performance are presented for an axial-flow compressor rotor designed to study the effects of blade solidity on efficiency and stall margin. The rotor was designed for a tip speed of 1380 feet per second, a blade tip solidity of 1.3, and a weight flow per unit annulus area of 41.1 pounds per second per square foot. Data were obtained for speeds from 50 to 100 percent of design and over a flow range from maximum flow to stall.

At design speed the peak efficiency was 0.844 and occurred at an equivalent weight flow of 63.5 pounds per second with a total pressure ratio of 1.801. Design values of efficiency, weight flow, and pressure ratio were 0.814, 65.3, and 1.65, respectively. Stall margin for design speed was 6.4 percent based on the weight flow and pressure ratio at peak efficiency and that just prior to stall.

Calculations based on radial surveys of total pressure, total temperature, and flow angle indicated that the losses were lower than design except in the region of the damper and the hub. The radial survey data indicate that the damper affected the blade element performance over approximately 30 to 40 percent of the blade span. The estimated effect on the rotor performance was 3 points in efficiency.

It is concluded that the higher-than-design pressure ratio, temperature ratio, and efficiency of this rotor are primarily a result of the actual losses being generally lower than those assumed in the design. The lower loss level resulted in a higher pressure rise, which reduced the velocity ratio to less than design values. This reduction in velocity ratio further increased the pressure ratio as a result of increasing the energy addition to greater than design.

INTRODUCTION

The Lewis Research Center of the National Aeronautics and Space Administration is engaged in a research program on axial-flow fans and compressors for advanced air-breathing engines. The program is directed primarily towards providing the technology to permit reducing the size and weight of the fans and compressors while maintaining a high level of performance. In support of this program, experimental studies are being conducted on improved blade shapes for high Mach number operation and the effect of blade aspect ratio, blade solidity, blade loading, area margin above choke, weight flow per unit annulus area, velocity ratio, and blade spacing on efficiency and stall margin.

This report presents the aerodynamic design parameters, along with the overall and blade element performance, of an axial-flow compressor rotor designed primarily to study the effect of blade row solidity on efficiency and stall margin. The rotor presented in this report, designated rotor 3, has a tip solidity of 1.3. It is one of a series of rotors designed to change blade solidity by varying the subsonic (rearward) portion of the blade chord (refs. 1 and 2). Overall and blade element performance data for rotor 3 were obtained for six speeds from 50 to 100 percent of design speed. Blade element data were obtained at 11 radial positions.

All symbols used in the report are defined in appendix A. Performance parameters are presented in appendix B. The definitions and units used for the performance parameters in tables IV to XV are presented in appendix C. All parameters shown in this report are expressed in English units.

AERODYNAMIC DESIGN

This rotor was designed using the method discussed in reference 1. Basically that method consists of (1) calculating the flow field ahead of and behind the rotor to establish the desired velocity diagrams, (2) determining the blade element geometry to produce the desired velocity diagrams, and (3) stacking the blade elements and generating coordinates for blade fabrication.

A computer program referred to as the streamline analysis program was used to calculate the flow field at several axial locations, including the axial locations approximating the blade leading- and trailing-edge planes. This program accounts for streamline curvatures and entropy and enthalpy gradients. Inputs to the program are flow path geometry (fig. 1), weight flow, rotative speed, and the desired radial distribution of total pressure and total temperature at the blade inlet and outlet. Boundary-layer blockages (actual area minus effective area divided by actual area) are also input to the program. For this design the boundary-layer blockages at the rotor inlet and outlet were

0.02 and 0.04, respectively.

Another computer program, referred to as the blade geometry program, was used to calculate a blade shape to produce the desired velocity diagrams as determined by the streamline analysis program. The rotor losses and exit temperature distribution are calculated within the blade geometry program. If this calculated temperature distribution does not agree with that from the streamline analysis program, another flow field calculation is made with the streamline analysis program using the temperature distribution from the blade geometry program. This iterative procedure is continued until the temperature distribution is consistent with the losses and desired pressure distribution.

After the blade geometry has been defined, the blade coordinates program presented in reference 3 is used to compute the blade elements on conical surfaces approximating the stream surfaces passing through the blade. The program then stacks these blade elements on a radial line about their center of gravity and computes the Cartesian coordinates for fabrication.

The overall design parameters for this 19.77-inch-diameter rotor are presented in table I. The rotor was designed to have a blade tip solidity of 1.3, an aspect ratio of 2.53 (based on mean blade height and cylindrical chord at the exit hub radii), and an inlet hub-tip ratio of 0.51. This resulted in 47 blades with tip aerodynamic chord of 1.72 inches. The design flow path is presented in figure 1. The rotor location as well as the radial survey instrumentation locations are also shown.

The design blade element and blade geometry parameters are presented in tables II and III, respectively. The design incidence angles, deviation angles, aerodynamic loadings, loss coefficients, and loss parameters are presented in table II.

The multiple-circular-arc (MCA) blade shape (ref. 4) was used for blade elements from the tip to 40 percent of span. The double-circular-arc (DCA) blade shape was used for the remainder of the blade. For the MCA blade elements, the maximum thickness and transition point (the point where the forward and rear circular-arc sections join) were located at the calculated shock position. The X-factor (ratio of suction-surface camber ahead of the assumed shock location of the MCA blade section to that of a DCA blade section) was varied linearly from 0.552 at the tip to 1.0 at 40 percent of span (table III) to provide a smooth transition from MCA elements to DCA elements.

The area ratio margin calculation used in the design of this rotor assumed the minimum area to occur immediately behind the assumed shock location and accounted for both streamline convergence and the loss across the shock (see table III for radial distribution). The MCA elements should provide for a reduction in shock loss due to the lower suction-surface Mach number just ahead of the shock. The calculated peak suction-surface Mach numbers and suction-surface camber are listed in tables II and III, respectively.

For the design of this rotor it was assumed that the minimum loss would occur at

zero incidence angle. Deviation angle and loss calculations were based on the method described in reference 1. The profile losses (ref. 5) were based on the curves of loss as a function of diffusion factor shown in figure 2.

APPARATUS AND PROCEDURE

Test Facility

The facility used in the investigation is the same as that described in detail in reference 1. A schematic of the facility is shown in figure 3. The facility is sized for a maximum flow rate of 100 pounds per second. A variable-frequency, 15 000-horsepower synchronous motor and a gearbox are used to drive the research compressor to speeds up to 17 500 rpm. For the present study, air entered the test facility at an inlet on the roof of the building and was exhausted to a low-pressure (20 in. Hg vacuum) exhaust system. The research rotor was straddle-mounted on a shaft supported by two hydrodynamic bearings, as shown in figure 4. Carbon face seals were used to prevent bearing oil leakage.

Test Rotor

The test rotor is shown in figure 5. The rotor blades were machined from Maraging 200 steel bar stock. Dampers were located at 43 percent of span from the rotor tip to minimize blade vibration. The meanline of the damper approximated a section of a conical surface with the cone angle set equal to the streamline angle. The aerodynamic chord of the damper is approximately 60 percent of the aerodynamic chord of the blade. The thickness of the damper is approximately 15 percent of the aerodynamic chord of the damper. The damper thickness was held essentially constant, with the leading- and trailing-edge radii set equal to one-half the thickness of the damper. The damper viewed from the blade leading edge and from the blade pressure surface is shown in figure 6.

Instrumentation

The axial locations of survey instrumentation are shown in figure 1, and the circumferential locations are shown in figure 7. In the plenum chamber, two pressure taps and two thermocouples were installed to measure plenum pressure and temperature. At

the rotor inlet (station 1), a wedge probe (fig. 8) was used to measure static pressure. At the rotor outlet (station 2), two combination probes (fig. 9) were used to measure total pressure, total temperature, and flow angle. Static pressure at station 2 was measured by two wedge probes. One inner-wall and one outer-wall static pressure tap were located at each of the survey planes. A hot film probe was located at the inlet survey plane for use in determining stall.

Strain-gage-type transducers were used in measuring pressures. Iron-constantan thermocouples were used in conjunction with a constant-temperature (610° R) oven to determine temperature. Flow through the compressor was determined from a thin-plate orifice.

Compressor speed was indicated with the use of a magnetic pickup in conjunction with a gear mounted on the drive-motor shaft. All data were measured by an automatic digital potentiometer and recorded on paper tape. The overall accuracy of the measurements is estimated to be

Inlet pressure, psi	±0.05
Outlet pressure, psi	±0.10
Temperature, °R	±1.0
Weight flow, lb/sec	±1.0
Speed, rpm	±50
Flow angle, deg	±2

Test Procedure

Compressor test data were taken over a range of weight flows from maximum flow to stall conditions. For each weight flow, measurements were recorded at 11 radial positions. The data were obtained at 50, 60, 70, 80, 90, and 100 percent of equivalent design speed. All probes were inserted into the flow stream simultaneously in obtaining the data. Initial tests indicated that the insertion of the probes in front of the rotor did not affect the readings from the probes behind the rotor.

The stall points were established by increasing the back pressure on the compressor until a rapid fluctuation was noted in the signal from a hot film gage located at the rotor inlet. Also fluctuations in compressor discharge pressure and blade stress were observed when stall was encountered. The flow at which this condition occurred was indicated on an X-Y plotter which recorded the compressor discharge pressure as a function of weight flow. When the stalled conditions were noted, the discharge throttle was immediately opened. The weight flow was then set to within 1 pound of the weight flow at which stall occurred to obtain the blade element performance near stall.

Performance Calculation Procedure

Measured outlet total temperatures and total pressures were corrected for Mach number and streamline slope. These corrections were based on instrument probe calibrations given in reference 6. The stream static pressure was corrected for Mach number and streamline slope based on an average calibration for the type of probes used.

The data presented here have been corrected to standard-day conditions at the plenum. The rotor inlet total pressure and total temperature were assumed to be radially constant at the values equal to the plenum values. The inlet flow angle was assumed to be zero degrees. At each radial position, the two outlet total pressures, total temperatures, and flow angles were each averaged to obtain the outlet radial distributions. Due to the physical size of the wedge probe, the static pressures were not measured at the 5- and 10-percent span positions. The probe was set at 0.75 inch from the outer wall for the first two radial positions, and the values measured were assumed to be equal to the static pressure at the 5- and 10-percent span positions. Since the wedge probe static pressure agreed closely with the wall static measurement, only small gradients in static pressure existed at the blade tip. The outlet static pressure at the 90- and 95-percent span positions was obtained from a fairing between the measured static pressure at 70 percent of span and the measured inner-wall static pressure.

The overall and blade element performance were calculated based on the equations presented in appendix B. Overall performance was obtained from mass-averaged survey data at the rotor exit and plenum values of pressure and temperature. The blade element data have been translated from the measuring stations to planes approximating the blade leading and trailing edges by the method described in reference 1.

RESULTS AND DISCUSSION

The results of this investigation are presented in the form of overall performance and blade element performance. Blade element performance is presented as a function of percent span for three weight flows at design speed and as a function of incidence angle for three speeds. In addition to the machine-plotted parameters, several other performance parameters are presented in tabular form. The overall performance is presented in tables IV and IX and the blade element performance in tables X to XV. The definition and units used for the various parameters are presented in appendix C.

Overall Performance

The overall performance of rotor 3 is plotted in figure 10. Total pressure ratio, total temperature ratio, and temperature rise efficiency are presented as a function of equivalent weight flow. The data are presented for rotative speeds of 50, 60, 70, 80, 90, and 100 percent of design speed.

The peak efficiency for the rotor at design speed was 0.844, as compared to a design value of 0.814. Peak efficiency occurred at an equivalent weight flow of 63.5 pounds per second, as compared to the design weight flow of 65.3 pounds per second (41.1 lb/sec/sq ft of annulus area). Total pressure ratio and total temperature ratio at the weight flow corresponding to peak efficiency were 1.801 and 1.217, respectively, as compared to design values of 1.65 and 1.189. Stall margin at design speed was calculated to be 6.4 percent based on the weight flows and pressure ratios at peak efficiency and near stall conditions.

At the lower speeds, the peak efficiency increased to approximately 0.90. It should be pointed out that data accuracy would be expected to deteriorate somewhat at the lower speeds.

Blade Element Performance

Radial distribution of performance parameters. - The radial distribution of several performance parameters is presented in figure 11 for three weight flows at design speed. The weight flow points selected correspond to near maximum flow, design flow, and near stall flow. The design distributions are also shown in figure 11 by dashed lines.

At the design weight flow of 65.3 pounds per second, the measured pressure ratio was greater than design along the entire blade span except in the region of the damper (approximately 43 percent of span). The efficiency was also greater than design except in the damper and hub regions. Although the blade loading (as indicated by the diffusion factor) was appreciably higher than design over the complete span, the losses were less than or equal to design except in the damper and hub regions. The calculated inlet velocity was greater than design, and the incidence angle was slightly less than design. Deviation angle was higher than design in the tip and damper regions, while in the midspan and hub regions the deviation angle was less than design.

The dampers have a very detrimental effect on the aerodynamic performance. As shown in figure 11, 30 to 40 percent of the blade span was affected by the dampers. The lower pressure ratio and efficiency in the region of the damper are attributed to the losses associated with the damper. The estimated decrement in efficiency as a result of the dampers was approximately 3 points at design weight flow. No attempt was made to

account for the damper effects in the aerodynamic design of the rotor.

It is apparent from the data presented in figure 11 that the effect of the end walls on the performance parameters was not adequately accounted for in the design. This is particularly true of the effect of the end walls on the gradient in losses in these regions.

In noting the radial variation in performance parameters, it is apparent that the higher-than-design overall pressure ratio (fig. 10) was primarily a result of much-higher-than-design pressure ratios in the blade tip region. The higher-than-design overall efficiency is attributed to the generally low level of loss across the blade span as compared to design. Even with the high losses in the damper region, the overall efficiency was higher than design.

Performance parameters as a function of incidence angle. - Several performance parameters are presented as a function of suction-surface incidence angle in figure 12. The data are plotted for 60, 80, and 100 percent of design speed for blade elements at 5, 10, 30, 50, 70, 90, and 95 percent of span from the rotor tip. Design values of the various parameters are shown by solid symbols. These plots of the blade element and performance parameters as a function of incidence angle show that the incidence angles (with reference to the suction surface) associated with minimum loss varied from $-1\frac{1}{2}^{\circ}$ in the tip region to near design in the hub region for design speed. Design incidence was zero for all elements.

All blade elements were operating at or very near minimum loss at design speed and design flow. Therefore, the performance parameters as a function of percent span presented in figure 11 for the near-design-weight-flow point are essentially those for minimum blade element loss. The deviation angles associated with minimum loss varied, in general, from $1\frac{1}{2}^{\circ}$ above the design value in the tip region to $4\frac{1}{2}^{\circ}$ below the design value in the hub region.

The loss parameter presented in figure 12 is based on the measured total loss coefficient, which includes a shock loss for elements operating at high subsonic and supersonic inlet relative velocities. In the tabulated data, a loss parameter is presented based on the measured total loss coefficient minus a calculated shock loss and is referred to as the profile loss. In comparing the profile loss parameter presented in tables X to XV with that assumed in the design (fig. 2), it is evident that the curves of loss as a function of loading and percent span used in the design did not adequately predict the level of loss or the gradient in loss which exists in the end wall regions of the blades, particularly in the hub region. The loss parameter as a function of loading used in the design was based on the correlation presented in reference 5. The generally lower calculated profile loss for the tip region may, in part, be a result of the calculated shock loss being too high. However, even when comparing the loss parameter based on total loss, the same general conclusions can be drawn. The design loss presented in table II is slightly higher in the hub region than the loss as a function of diffusion factor based on

the correlation in figure 2. The loss values in figure 2 were used in arriving at the design. The difference between the design loss in table II and the values based on figure 2 was due to an error in calculating the ideal relative total pressure ratio. The radius change across the rotor was neglected in the calculation and resulted in the design loss being slightly higher in the hub region than was intended based on the loss correlation in figure 2. The difference between design and measured values of loss is, in part, a result of the error in arriving at the design values.

REMARKS

The higher-than-design pressure ratio, temperature ratio, and efficiency of this rotor are primarily a result of the actual losses being generally lower than those assumed in the design. The higher pressure rise caused a reduction in the velocity ratio. This reduction in velocity ratio further increased the pressure ratio as a result of increasing the energy addition above design. The magnitude between measured performance and design values differs between reference 1 and this rotor, but the trend remains the same.

The lower loss than that predicted based on the correlation presented in reference 5 may, in part, be a result of the blade solidity being higher than the average solidity of the rotors used in the correlation. A large percentage of the rotors used in the correlation used 65-series blade sections as compared to the circular-arc-type sections used on rotor 3. The inlet relative Mach number for this rotor is also much higher than that for the correlation. The diffusion factor is based on subsonic flow, but was used for the blade sections operating with transonic flow. For the present design, damper and end wall effects were not considered. It is concluded that a real need exists to improve and/or change the loss correlation parameters to more accurately account for blade solidity, Mach number, and the end wall and damper effects.

The effect of the part-span vibration dampers on the aerodynamic performance was quite pronounced for this rotor. The relatively blunt dampers affected the flow over 30 to 50 percent of the blade span. The estimated loss in efficiency was 3 points. When dampers are required, it probably would be advantageous to minimize damper size and to align the damper with the local stream surface. This should reduce both the losses associated with the damper and the damper wake.

SUMMARY OF RESULTS

The overall performance and the blade element performance of an axial-flow com-

pressor rotor have been presented. The rotor was designed for a tip speed of 1380 feet per second, a blade tip solidity of 1.3, and a weight flow per unit annulus area of 41.1 pounds per second per square foot. It was tested over a range of flows from maximum flow to stall and at speeds from 50 to 100 percent of design speed. Radial surveys were taken at 11 radial positions. The investigation yielded the following principal results:

1. At design speed the peak efficiency was 0.844 and occurred at an equivalent weight flow of 63.5 pounds per second. The total pressure ratio was 1.801 and the temperature ratio was 1.217. Design values of efficiency, weight flow, pressure ratio, and temperature ratio were 0.814, 65.3, 1.65, and 1.189, respectively.

2. Stall margin for design speed was 6.4 percent, based on the weight flow and pressure ratio at peak efficiency and that just prior to stall.

3. The blade damper affected the flow over approximately 30 to 40 percent of the blade span. The estimated decrement in blade efficiency was 3 points.

4. The losses were, in general, lower than design, with steep gradients existing in the end wall and damper regions of the blades.

5. Incidence angles (with reference to the suction surface) associated with minimum loss varied from $-1\frac{1}{2}^{\circ}$ to design for design speed.

6. Deviation angles associated with minimum loss varied by $+1\frac{1}{2}^{\circ}$ to $-4\frac{1}{2}^{\circ}$ from design values. Deviation angles were higher than design in the tip region by as much as $1\frac{1}{2}^{\circ}$ and higher than design in the midspan-to-hub region by as much as 3° , except for 95 percent of span. For 95 percent of span, the deviation was $4\frac{1}{2}^{\circ}$ less than design.

Lewis Research Center,

National Aeronautics and Space Administration,

Cleveland, Ohio, November 19, 1971,

764-74.

APPENDIX A

SYMBOLS

A_{an}	annulus area at rotor inlet, 1.586 ft ²
A_{fr}	frontal area at rotor inlet, 2.132 ft ²
a	distance from blade leading edge to maximum camber point
C_p	specific heat at constant pressure, 0.24 Btu/(lb)(°R)
c	chord length, in.
D	diffusion factor
g	acceleration of gravity, 32.18 ft/sec ²
i_{mc}	incidence angle, angle between inlet air direction and line tangent to blade mean camber line at leading edge, deg
i_{ss}	incidence angle, angle between inlet air direction and line tangent to blade suction surface at leading edge, deg
J	mechanical equivalent of heat, 778.16 ft-lb/Btu
N	rotor speed, rpm
P	total pressure, psia
p	static pressure, psia
R	gas constant, 53.25 ft-lb/(lb)(°R)
r	radius, in.
SM	stall margin
T	total temperature, °R
U	rotor speed, ft/sec
V	air velocity, ft/sec
W	weight flow, lb/sec
X -factor	ratio of suction-surface camber ahead of assumed shock location of the MCA blade section to that of a DCA blade section
Z	displacement along compressor axis, in.
α_c	cone angle, deg
α_s	streamline slope, deg

β	air angle, angle between air velocity and meridional plane, deg
β'_c	relative meridional air angle based on cone angle, $\arctan(\tan \beta'_m \cos \alpha_c / \cos \alpha_s)$, deg
γ	ratio of specific heats, 1.40 Btu/(lb)(^o R)
γ_b	blade setting angle, deg
δ	ratio of inlet total pressure to standard pressure of 14.69 psia
δ^o	deviation angle, angle between exit air direction and tangent to blade mean camber line at trailing edge, $(\beta'_c)_{TE} - (\kappa_{mc})_{LE}$, deg
η	efficiency
θ	ratio of inlet total temperature to standard temperature of 518.7 ^o R
κ_{mc}	angle between blade mean camber line at leading or trailing edge and meridional plane, deg
κ_{ss}	angle between blade suction-surface camber line at leading edge and meridional plane, deg
σ	solidity, ratio of chord to spacing
φ	camber angle, deg
$\bar{\omega}$	total loss coefficient
$\bar{\omega}_p$	profile loss coefficient
$\bar{\omega}_s$	shock loss coefficient

Subscripts:

ad	adiabatic (temperature rise)
id	ideal
LE	blade leading edge
m	meridional direction
mc	mean camber line
mom	momentum rise
r	radial direction
ss	suction-surface camber line
TE	blade trailing edge
z	axial direction
θ	tangential direction

- 1 instrument plane upstream of rotor
- 2 instrument plane downstream of rotor

Superscript:

- ' relative to rotor

APPENDIX B

PERFORMANCE PARAMETERS

The performance parameters referred to in the main text are defined as follows:

Incidence angle based on suction-surface blade angle:

$$i_{ss} = (\beta'_c)_{LE} - (\kappa_{ss})_{LE} \quad (B1)$$

Incidence angle based on mean blade angle:

$$i_{mc} = (\beta'_c)_{LE} - (\kappa_{mc})_{LE} \quad (B2)$$

Deviation:

$$\delta^0 = (\beta'_c)_{TE} - (\kappa_{mc})_{TE} \quad (B3)$$

Diffusion factor:

$$D = 1 - \frac{V'_{TE} + \frac{(rV_\theta)_{TE} - (rV_\theta)_{LE}}{(r_{LE} + r_{TE})\sigma V'_{LE}}}{V'_{LE}} \quad (B4)$$

Total loss coefficient:

$$\bar{\omega} = \frac{(P'_{id})_{TE} - P'_{TE}}{P'_{LE} - P_{LE}} \quad (B5)$$

Profile loss coefficient:

$$\bar{\omega}_p = \bar{\omega} - \bar{\omega}_s \quad (B6)$$

Total loss parameter:

$$\frac{\bar{\omega} \cos(\beta'_m)_{TE}}{2\sigma} \quad (B7)$$

Profile loss parameter:

$$\frac{(\omega - \omega_s) \cos(\beta'_m)_{TE}}{2\sigma} \quad (B8)$$

Adiabatic efficiency:

$$\eta_{ad} = \frac{\left(\frac{P_{TE}}{P_{LE}}\right)^{\frac{\gamma-1}{\gamma}} - 1}{\frac{T_{TE}}{T_{LE}} - 1} \quad (B9)$$

Stall margin:

$$SM = \left[\frac{\left(\frac{P_{TE}}{P_{LE}}\right)_{STALL} \times \left(\frac{W\sqrt{\theta}}{\delta}\right)_{REF}}{\left(\frac{P_{TE}}{P_{LE}}\right)_{REF} \times \left(\frac{W\sqrt{\theta}}{\delta}\right)_{STALL}} - 1 \right] \times 100 \quad (B10)$$

Momentum rise efficiency:

$$\eta_{mom} = \frac{\left(\frac{P_{TE}}{P_{LE}}\right)^{\frac{\gamma-1}{\gamma}}}{\frac{(UV_{\theta})_{TE} - (UV_{\theta})_{LE}}{T_{LE} g J C_p}} \quad (B11)$$

Equivalent weight flow:

$$\frac{W\sqrt{\theta}}{\delta} \quad (B12)$$

Equivalent rotative speed:

$$\frac{N}{\sqrt{\theta}} \quad (\text{B13})$$

Equivalent weight flow per unit annulus area:

$$\frac{w\sqrt{\theta}}{A_{\text{an}}\delta} \quad (\text{B14})$$

Equivalent weight flow per unit frontal area:

$$\frac{w\sqrt{\theta}}{A_{\text{fr}}\delta} \quad (\text{B15})$$

APPENDIX C

DEFINITIONS AND UNITS USED IN TABLES

ABS	absolute
AERO CHORD	aerodynamic chord, in.
AREA RATIO	ratio of actual flow area to critical area (where local Mach number is 1)
BETAM	meridional air angle, deg
CONE ANGLE	angle between axial direction and conical surface representing blade element, deg
DELTA INC	difference between mean camber blade angle and suction-surface blade angle, deg
DEV	deviation angle (defined by eq. (B3)), deg
D-FACT	diffusion factor (defined by eq. (B4))
EFF	adiabatic efficiency (defined by eq. (B9))
IN	inlet (leading edge of blade)
INCIDENCE	incidence angle (suction surface defined by eq. (B1) and mean defined by eq. (B2))
KIC	angle between blade mean camber line and meridional plane at leading edge, deg
KOC	angle between blade mean camber line and meridional plane at trailing edge, deg
KTC	angle between blade mean camber line and meridional plane at transition point, deg
LOSS COEFF	loss coefficient (total defined by eq. (B5) and profile defined by eq. (B6))
LOSS PARAM	loss parameter (total defined by eq. (B7) and profile defined by eq. (B8))
MERID	meridional
MERID VEL R	meridional velocity ratio
OUT	outlet (trailing edge of blade)

PERCENT SPAN	percent of blade span from tip at rotor outlet
PHISS	suction-surface camber ahead of assumed shock location, deg
PRESS	pressure, psia
PROF	profile
RADII	radius, in.
REL	relative to the blade
RI	inlet radius (leading edge of blade), in.
RO	outlet radius (trailing edge of blade), in.
RP	radial position
RPM	equivalent rotative speed, rpm
SETTING ANGLE	angle between aerodynamic chord and meridional plane, deg
SOLIDITY	ratio of aerodynamic chord to blade spacing
SPEED	speed, ft/sec
SS	suction surface
STREAMLINE SLOPE	slope of streamline, deg
TANG	tangential
TEMP	temperature, °R
TI	thickness of blade at leading edge, in.
TM	thickness of blade at maximum thickness, in.
TO	thickness of blade at trailing edge, in.
TOT	total
TOTAL CAMBER	difference between inlet and outlet blade mean camber line, deg
VEL	velocity, ft/sec
WT FLOW	equivalent weight flow, lbm/sec
X FACTOR	ratio of suction-surface camber ahead of assumed shock location of multiple-circular-arc blade section to that of double-circular-arc blade section
ZMC	axial distance to blade maximum thickness point from inlet, in.
ZOC	axial distance to blade trailing edge from inlet, in.
ZTC	axial distance to transition point from inlet, in.

REFERENCES

1. Ball, Calvin L.; Janetzke, David C.; and Reid, Lonnie: Performance of a 1380 Foot-Per-Second-Tip-Speed Axial-Flow Compressor Rotor with Blade Tip Solidity of 1.5. NASA TM X-2379, 1972.
2. Janetzke, David C.; Ball, Calvin L.; and Hager, Roy D.: Performance of a 1380 Foot-Per-Second-Tip-Speed Axial-Flow Compressor Rotor with Blade Tip Solidity of 1.1. NASA TM X-2449, 1972.
3. Crouse, James E.; Janetzke, David C.; and Schwirian, Richard E.: A Computer Program for Composing Compressor Blading from Simulated Circular-Arc Elements on Conical Surfaces. NASA TN D-5437, 1969.
4. Monsarrat, N. T.; and Keenan, K. J.: Experimental Evaluation of Transonic Stators-Preliminary Analysis and Design Report. Rep. PWA-2749, Pratt & Whitney Aircraft (NASA CR-54620), 1967.
5. Johnsen, Irving A.; and Bullock, Robert O., eds.: Aerodynamic Design of Axial-Flow Compressors. NASA SP-36, 1965.
6. Glawe, George E.; Krause, Lloyd N.; and Dudzinski, Thomas J.: Small Combination Sensing Probe for Measurement of Temperature, Pressure, and Flow Direction. NASA TN D-4816, 1968.

TABLE I. - DESIGN OVERALL PARAMETERS FOR ROTOR 3

TOTAL PRESSURE RATIO	1.650
TOTAL TEMPERATURE RATIO	1.189
EFFICIENCY	0.814
WT FLOW PER UNIT FRONTAL AREA	30.614
WT FLOW PER UNIT ANNULUS AREA	41.139
WT FLOW	65.261
RPM	16000.000
TIP SPEED	1380.206

TABLE II. - DESIGN BLADE ELEMENT PARAMETERS FOR ROTOR 3

RP	RADII		ABS BETAM		REL BETAM		TOTAL TEMP		TOTAL PRESS	
	IN	OUT	IN	OUT	IN	OUT	IN	RATIO	IN	RATIO
TIP	9.885	9.769	-0.	40.9	64.5	54.6	518.7	1.228	14.69	1.650
1	9.729	9.578	-0.	40.6	64.0	53.7	518.7	1.222	14.69	1.650
2	9.510	9.386	0.	40.2	63.1	52.7	518.7	1.216	14.69	1.650
3	8.598	8.620	0.	38.2	59.7	48.4	518.7	1.191	14.69	1.650
4	8.127	8.237	0.	38.7	58.1	45.5	518.7	1.187	14.69	1.650
5	8.020	8.142	0.	38.9	57.7	44.7	518.7	1.186	14.69	1.650
6	7.893	8.046	0.	39.1	57.2	43.9	518.7	1.186	14.69	1.650
7	7.772	7.950	0.	39.2	56.9	43.0	518.7	1.184	14.69	1.650
8	7.652	7.854	0.	39.3	56.5	42.1	518.7	1.183	14.69	1.650
9	6.665	7.089	0.	39.9	53.4	34.0	518.7	1.174	14.69	1.650
10	5.558	6.323	0.	40.8	51.6	23.7	518.7	1.166	14.69	1.650
11	5.240	6.131	0.	41.2	51.6	20.7	518.7	1.164	14.69	1.650
HUB	5.000	5.940	-0.	41.6	51.4	17.6	518.7	1.163	14.69	1.650

RP	ABS VEL		REL VEL		MERID VEL		TANG VEL		WHEEL SPEED	
	IN	OUT	IN	OUT	IN	OUT	IN	OUT	IN	OUT
TIP	659.0	793.5	1529.5	1035.6	659.0	599.7	-0.	519.7	1380.2	1364.0
1	663.2	794.6	1511.7	1017.9	663.2	603.1	-0.	517.3	1358.4	1337.3
2	673.2	795.4	1488.7	1002.4	673.2	607.6	0.	513.3	1327.8	1310.5
3	700.6	800.5	1390.0	947.8	700.6	629.2	0.	494.8	1200.5	1203.6
4	705.2	809.9	1336.0	902.3	705.2	632.2	0.	506.3	1134.7	1150.1
5	708.1	813.0	1324.9	890.1	708.1	632.6	0.	510.6	1119.8	1136.8
6	709.2	816.1	1310.5	878.8	709.2	633.5	0.	514.4	1102.1	1123.4
7	708.5	819.0	1296.0	868.3	708.5	634.8	0.	517.6	1085.2	1110.0
8	708.2	822.3	1281.8	858.5	708.2	636.5	0.	520.6	1068.4	1096.6
9	691.0	854.4	1159.1	791.0	691.0	655.8	0.	547.5	930.6	989.8
10	614.1	895.7	989.6	740.0	614.1	677.7	0.	585.6	776.0	882.9
11	579.5	907.3	933.3	729.8	579.5	682.6	0.	597.8	731.6	856.0
HUB	557.8	920.2	893.6	722.6	557.8	688.6	-0.	610.4	698.1	829.4

RP	ABS MACH NO		REL MACH NO		MERID MACH NO		STREAMLINE SLOPE		MERID PEAK SS	
	IN	OUT	IN	OUT	IN	OUT	IN	OUT	VEL R	MACH NO
TIP	0.612	0.670	1.421	0.874	0.612	0.506	-8.70	-6.70	0.910	1.624
1	0.616	0.672	1.405	0.861	0.616	0.510	-7.60	-5.50	0.909	1.624
2	0.626	0.675	1.385	0.851	0.626	0.516	-6.55	-4.15	0.903	1.626
3	0.654	0.687	1.297	0.814	0.654	0.540	-0.55	1.10	0.898	1.642
4	0.659	0.698	1.248	0.777	0.659	0.545	2.55	3.85	0.896	1.616
5	0.661	0.701	1.238	0.767	0.661	0.545	3.40	4.58	0.893	1.611
6	0.663	0.704	1.224	0.758	0.663	0.546	4.05	5.37	0.893	1.601
7	0.662	0.707	1.211	0.750	0.662	0.548	5.03	6.00	0.896	1.595
8	0.662	0.711	1.197	0.742	0.662	0.550	5.90	6.83	0.899	1.587
9	0.644	0.744	1.081	0.689	0.644	0.571	14.30	14.32	0.949	1.525
10	0.568	0.788	0.915	0.651	0.568	0.596	26.25	24.50	1.104	1.304
11	0.534	0.800	0.860	0.644	0.534	0.602	30.05	27.75	1.178	1.229
HUB	0.513	0.814	0.821	0.639	0.513	0.609	32.90	31.00	1.235	1.176

RP	PERCENT		INCIDENCE		DEV	D-FACT	EFF	LOSS COEFF		LOSS PARAM	
	SPAN		MEAN	SS				TOT	PROF	TOT	PROF
TIP	0.		2.1	0.0	7.3	0.450	0.676	0.275	0.164	0.060	0.036
1	4.99		2.3	0.0	6.9	0.451	0.692	0.259	0.150	0.056	0.033
2	10.00		2.6	0.0	6.4	0.450	0.712	0.243	0.137	0.053	0.030
3	30.01		4.1	0.0	4.0	0.436	0.804	0.166	0.071	0.036	0.016
4	40.01		4.9	0.0	4.5	0.444	0.823	0.157	0.075	0.034	0.016
5	42.49		5.0	0.0	4.7	0.448	0.825	0.156	0.077	0.034	0.017
6	45.00		5.2	0.0	4.7	0.450	0.829	0.155	0.080	0.034	0.018
7	47.51		5.3	0.0	5.0	0.452	0.834	0.152	0.080	0.033	0.018
8	50.01		5.5	0.0	5.1	0.452	0.839	0.149	0.081	0.033	0.018
9	69.99		6.5	0.0	6.4	0.442	0.884	0.120	0.079	0.025	0.017
10	90.00		7.3	0.0	8.7	0.389	0.927	0.093	0.090	0.019	0.018
11	95.01		7.4	0.	9.4	0.358	0.937	0.089	0.089	0.017	0.017
HUB	100.00		7.5	0.0	11.3	0.327	0.946	0.082	0.082	0.014	0.014

TABLE III. - BLADE GEOMETRY FOR ROTOR 3

RP	PERCENT SPAN	RADII		BLADE ANGLES			DELTA INC
		RI	RO	KIC	KTC	KOC	
TIP	0.	9.885	9.769	62.50	58.45	47.30	2.10
1	5.	9.729	9.578	61.80	57.37	46.80	2.26
2	10.	9.510	9.386	60.62	55.92	46.30	2.57
3	30.	8.598	8.620	55.62	50.08	44.42	4.11
4	40.	8.127	8.237	53.20	47.11	41.00	4.90
5	42.	8.020	8.142	52.60	46.43	40.03	5.04
6	45.	7.893	8.046	52.00	45.63	39.13	5.17
7	48.	7.772	7.950	51.44	44.85	38.03	5.34
8	50.	7.652	7.854	50.90	44.07	37.03	5.47
9	70.	6.665	7.089	46.70	37.25	27.45	6.54
10	90.	5.558	6.323	44.20	29.54	14.55	7.31
11	95.	5.240	6.131	44.10	27.26	10.82	7.42
HUB	100.	5.000	5.940	44.00	25.51	6.10	7.47

RP	BLADE THICKNESSES			AXIAL DIMENSIONS			CONE ANGLE
	TI	TM	TO	ZMC	ZTC	ZOC	
TIP	0.020	0.061	0.020	0.563	0.563	0.894	-6.300
1	0.020	0.064	0.020	0.564	0.564	0.927	-5.800
2	0.020	0.068	0.020	0.565	0.565	0.962	-4.700
3	0.020	0.085	0.020	0.552	0.552	1.109	0.900
4	0.020	0.094	0.020	0.551	0.551	1.183	4.100
5	0.020	0.096	0.020	0.561	0.561	1.200	5.000
6	0.020	0.098	0.020	0.573	0.573	1.217	5.800
7	0.020	0.101	0.020	0.581	0.581	1.234	6.700
8	0.020	0.103	0.020	0.589	0.589	1.252	7.600
9	0.020	0.122	0.020	0.650	0.650	1.390	15.600
10	0.020	0.143	0.020	0.689	0.689	1.486	26.800
11	0.020	0.149	0.020	0.688	0.688	1.488	30.400
HUB	0.020	0.154	0.020	0.685	0.685	1.486	32.600

RP	AERO CHORD	SETTING ANGLE	TOTAL CAMBER	X SOLIDITY	X FACTOR	PHISS	AREA RATIO
1	1.744	56.99	15.00	1.362	0.599	6.45	1.075
2	1.737	55.62	14.32	1.386	0.670	7.10	1.073
3	1.753	50.20	11.20	1.515	0.969	10.03	1.064
4	1.764	47.07	12.20	1.595	1.000	10.59	1.059
5	1.767	46.35	12.57	1.616	1.000	10.69	1.058
6	1.773	45.59	12.87	1.639	1.000	10.74	1.056
7	1.777	44.79	13.41	1.662	1.000	10.89	1.054
8	1.783	44.02	13.87	1.686	1.000	10.98	1.052
9	1.844	37.16	19.25	1.958	1.000	11.65	1.039
10	1.940	29.46	29.65	2.308	1.000	12.18	1.050
11	1.973	27.36	33.28	2.460	1.000	12.30	1.063
HUB	1.965	25.28	37.90	2.730	1.000	12.38	1.076

TABLE IV. - OVERALL PERFORMANCE FOR ROTOR 5, 50 PERCENT DESIGN SPEED

PARAMETER	READING							
	487	488	489	490	491	492	493	
TOTAL PRESSURE RATIO	1.165	1.161	1.149	1.128	1.110	1.084	1.051	
TOTAL TEMPERATURE RATIO	1.055	1.051	1.046	1.039	1.035	1.029	1.021	
TEMP RISE EFFICIENCY	0.815	0.855	0.885	0.895	0.872	0.816	0.678	
MOMENTUM RISE EFFICIENCY	0.823	0.873	0.904	0.929	0.915	0.894	0.787	
HT FLOW PER UNIT FRONTAL AREA	13.105	14.456	16.100	17.781	18.907	20.145	21.307	
HT FLOW PER UNIT ANNULUS AREA	17.769	19.577	21.833	24.115	25.640	27.316	28.894	
HT FLOW AT ORIFICE	27.763	30.588	34.114	37.676	40.062	42.680	45.146	
HT FLOW AT INLET	28.898	31.847	35.341	38.980	41.264	43.861	46.413	
HT FLOW AT OUTLET	26.899	29.737	32.727	35.996	37.857	39.983	41.960	
RPM	8077.590	8088.898	8102.659	8096.750	8115.157	8108.342	8114.995	
PERCENT OF DESIGN SPEED	50.484	50.556	50.641	50.605	50.707	50.677	50.719	

TABLE V. - OVERALL PERFORMANCE FOR ROTOR 3, 60 PERCENT DESIGN SPEED

PARAMETER	READING							
	494	496	497	498	499	500		
TOTAL PRESSURE RATIO	1.091	1.128	1.167	1.220	1.232	1.240		
TOTAL TEMPERATURE RATIO	1.035	1.043	1.052	1.066	1.071	1.075		
TEMP RISE EFFICIENCY	0.724	0.814	0.871	0.880	0.866	0.842		
MOMENTUM RISE EFFICIENCY	0.793	0.882	0.916	0.904	0.871	0.829		
HT FLOW PER UNIT FRONTAL AREA	25.460	22.851	21.787	19.051	17.738	16.359		
HT FLOW PER UNIT ANNULUS AREA	31.815	30.988	29.545	25.807	24.054	22.157		
HT FLOW AT ORIFICE	49.708	48.419	46.163	40.323	37.584	34.620		
HT FLOW AT INLET	50.991	49.635	47.286	41.251	38.275	35.432		
HT FLOW AT OUTLET	46.402	45.416	43.606	38.479	35.911	33.279		
RPM	9637.268	9627.997	9640.917	9621.054	9635.871	9640.810		
PERCENT OF DESIGN SPEED	60.233	60.178	60.266	60.151	60.222	60.255		

TABLE VI. - OVERALL PERFORMANCE FOR ROTOR 3, 70 PERCENT DESIGN SPEED

PARAMETER	READING						
	501	502	503	504	505	507	538
TOTAL PRESSURE RATIO	1.205	1.249	1.280	1.305	1.327	1.355	1.345
TOTAL TEMPERATURE RATIO	1.065	1.075	1.081	1.088	1.095	1.101	1.112
TEMP RISE EFFICIENCY	0.840	0.878	0.900	0.901	0.885	0.852	0.790
MOMENTUM RISE EFFICIENCY	0.868	0.903	0.905	0.907	0.890	0.845	0.787
WT FLOW PER UNIT FRONTAL AREA	25.096	24.537	23.743	22.819	21.428	19.627	17.589
WT FLOW PER UNIT ANNULUS AREA	34.032	33.274	32.198	30.945	29.058	26.616	23.852
WT FLOW AT ORIFICE	53.175	51.990	50.309	48.351	45.402	41.588	37.269
WT FLOW AT INLET	54.395	53.166	51.480	49.499	46.478	42.324	39.319
WT FLOW AT OUTLET	50.121	49.348	47.952	46.299	43.735	40.328	36.215
RPM	11223.402	11233.115	11220.266	11215.935	11214.970	11225.107	11277.022
PERCENT OF DESIGN SPEED.	70.146	70.207	70.127	70.100	70.094	70.157	70.487

TABLE VII. - OVERALL PERFORMANCE FOR ROTOR 3, 80 PERCENT DESIGN SPEED

PARAMETER	READING						
	513	515	517	518	539	540	541
TOTAL PRESSURE RATIO	1.333	1.405	1.440	1.459	1.461	1.467	1.467
TOTAL TEMPERATURE RATIO	1.102	1.116	1.124	1.131	1.136	1.143	1.150
TEMP RISE EFFICIENCY	0.862	0.880	0.887	0.868	0.841	0.811	0.774
MOMENTUM RISE EFFICIENCY	0.862	0.893	0.943	0.867	0.842	0.803	0.760
WT FLOW PER UNIT FRONTAL AREA	27.445	26.661	25.878	24.339	22.931	21.196	19.436
WT FLOW PER UNIT ANNULUS AREA	37.218	36.155	35.093	33.005	31.096	28.743	26.357
WT FLOW AT ORIFICE	58.152	56.492	54.832	51.570	48.587	44.911	41.183
WT FLOW AT INLET	59.279	57.786	55.914	52.470	49.510	45.646	41.696
WT FLOW AT OUTLET	54.504	53.470	49.666	49.094	45.721	43.611	40.178
RPM	12868.064	12866.485	12873.538	12879.623	12867.007	12868.739	12855.667
PERCENT OF DESIGN SPEED	80.425	80.415	80.460	80.498	80.419	80.367	80.348

TABLE VIII. - OVERALL PERFORMANCE FOR ROTOR 3, 90 PERCENT DESIGN SPEED

PARAMETER	READING				
	521	525	525	542	544
TOTAL PRESSURE RATIO	1.412	1.534	1.595	1.641	1.612
TOTAL TEMPERATURE RATIO	1.128	1.150	1.163	1.178	1.181
TEMP RISE EFFICIENCY	0.811	0.867	0.875	0.853	0.809
MOMENTUM RISE EFFICIENCY	0.816	0.867	0.875	0.858	0.798
WT FLOW PER UNIT FRONTAL AREA	29.838	29.373	28.468	27.003	25.022
WT FLOW PER UNIT ANNULUS AREA	40.463	39.932	38.605	36.618	33.932
WT FLOW AT ORIFICE	63.222	62.237	60.320	57.215	53.018
WT FLOW AT INLET	63.952	62.903	61.202	57.265	53.403
WT FLOW AT OUTLET	59.115	58.965	57.524	54.803	51.200
RPM	14435.497	14422.116	14418.835	14445.552	14435.400
PERCENT OF DESIGN SPEED	90.222	90.138	90.118	90.285	90.221

TABLE IX. - OVERALL PERFORMANCE FOR ROTOR 3, 100 PERCENT DESIGN SPEED

PARAMETER	READING						
	528	550	551	552	553	551	551
TOTAL PRESSURE RATIO	1.637	1.724	1.758	1.801	1.825	1.840	1.840
TOTAL TEMPERATURE RATIO	1.185	1.202	1.209	1.217	1.165	1.228	1.228
TEMP RISE EFFICIENCY	0.816	0.835	0.838	0.844	0.775	0.834	0.834
MOMENTUM RISE EFFICIENCY	0.812	0.831	0.839	0.851	0.777	0.832	0.832
WT FLOW PER UNIT FRONTAL AREA	31.225	30.823	30.588	29.955	31.314	29.583	29.583
WT FLOW PER UNIT ANNULUS AREA	42.344	41.799	41.480	40.622	42.465	40.117	40.117
WT FLOW AT ORIFICE	66.162	65.310	64.912	63.471	66.350	62.682	62.682
WT FLOW AT INLET	66.912	65.103	65.568	64.231	67.204	63.619	63.619
WT FLOW AT OUTLET	61.806	61.707	61.289	60.691	61.759	59.945	59.945
RPM	15947.168	15944.697	15950.182	15941.646	15927.812	16015.704	16015.704
PERCENT OF DESIGN SPEED	99.670	99.654	99.745	99.635	99.849	100.098	100.098

TABLE X. - BLADE ELEMENT PERFORMANCE FOR ROTOR 3, 50 PERCENT DESIGN SPEED

(a) Reading 487

RP	RADII		ABS BETAM		REL BETAM		TOTAL TEMP		TOTAL PRESS	
	IN	OUT	IN	OUT	IN	OUT	IN	OUT	IN	OUT
1	9.729	9.578	0.	55.9	69.5	55.5	518.7	557.3	14.69	17.29
2	9.510	9.386	0.	49.9	69.3	54.0	518.7	554.4	14.69	17.26
3	8.598	8.620	0.	41.9	67.6	48.8	518.7	546.7	14.69	17.21
4	8.127	8.237	0.	46.4	66.4	47.3	518.7	546.8	14.69	17.05
5	8.020	8.142	0.	49.9	66.1	47.5	518.7	547.1	14.69	16.98
6	7.893	8.046	0.	55.1	65.5	47.5	518.7	547.2	14.69	16.90
7	7.772	7.950	0.	59.0	65.1	48.4	518.7	547.4	14.69	16.83
8	7.652	7.854	0.	59.2	64.9	46.4	518.7	548.0	14.69	16.86
9	6.665	7.089	0.	43.0	61.3	32.9	518.7	543.2	14.69	17.12
10	5.588	6.323	0.	42.6	56.0	22.1	518.7	541.9	14.69	17.04
11	5.240	6.131	0.	43.5	54.3	16.1	518.7	542.6	14.69	17.17

RP	ABS VEL		REL VEL		MERID VEL		TANG VEL		WHEEL SPEED	
	IN	OUT	IN	OUT	IN	OUT	IN	OUT	IN	OUT
1	256.1	410.5	732.1	406.6	256.1	230.1	0.	340.0	685.9	675.2
2	254.1	401.5	718.8	440.3	254.1	258.5	0.	307.2	672.4	663.6
3	249.3	400.0	655.5	452.0	249.3	297.5	0.	267.4	606.2	607.7
4	250.2	394.5	625.3	401.7	250.2	272.3	0.	285.4	573.1	580.8
5	250.5	390.9	617.9	372.4	250.5	251.8	0.	299.0	564.9	573.5
6	253.2	391.5	609.8	331.8	253.2	224.2	0.	320.9	554.8	565.6
7	253.6	388.7	602.5	302.1	253.6	200.5	0.	333.1	546.5	559.0
8	254.0	397.5	597.6	295.1	254.0	203.4	0.	341.5	540.9	555.2
9	256.1	431.3	534.1	375.7	256.1	315.3	0.	294.3	468.7	498.5
10	265.0	457.4	473.6	363.4	265.0	336.6	0.	309.7	392.5	446.6
11	265.7	481.7	455.0	363.6	265.7	349.5	0.	331.5	369.3	432.1

RP	ABS MACH NO		REL MACH NO		MERID MACH NO		MERID VEL R	PEAK SS MACH NO	EFF
	IN	OUT	IN	OUT	IN	OUT			
1	0.231	0.359	0.659	0.356	0.231	0.201	0.898	0.991	0.640
2	0.229	0.352	0.647	0.386	0.229	0.227	1.017	1.001	0.685
3	0.224	0.353	0.590	0.399	0.224	0.263	1.193	1.006	0.854
4	0.225	0.348	0.563	0.355	0.225	0.240	1.088	0.977	0.803
5	0.226	0.345	0.556	0.329	0.226	0.222	1.005	0.970	0.769
6	0.228	0.345	0.549	0.293	0.228	0.198	0.885	0.955	0.742
7	0.228	0.343	0.543	0.267	0.228	0.177	0.790	0.947	0.713
8	0.229	0.351	0.538	0.260	0.229	0.179	0.801	0.944	0.710
9	0.231	0.383	0.481	0.334	0.231	0.280	1.231	0.847	0.942
10	0.239	0.407	0.427	0.324	0.239	0.300	1.270	0.707	0.969
11	0.239	0.430	0.410	0.324	0.239	0.312	1.315	0.657	0.988

RP	PERCENT SPAN		INCIDENCE		DEV	D-FACT	LOSS COEFF		LOSS PARAM	
	IN	OUT	MEAN	SS			TOT	PROF	TOT	PROF
1	3.19	4.99	7.8	5.5	8.7	0.614	0.332	0.332	0.069	0.069
2	7.68	10.00	8.7	6.2	7.7	0.541	0.280	0.280	0.059	0.059
3	26.35	30.01	12.0	7.9	4.4	0.445	0.124	0.124	0.027	0.027
4	35.99	40.01	13.2	8.3	6.3	0.502	0.182	0.182	0.039	0.039
5	38.18	42.49	13.4	8.4	7.4	0.548	0.220	0.220	0.046	0.046
6	40.78	45.00	13.4	8.2	8.3	0.618	0.251	0.251	0.052	0.052
7	43.25	47.51	13.6	8.3	10.4	0.667	0.287	0.287	0.057	0.057
8	45.71	50.01	13.9	8.4	9.3	0.678	0.300	0.300	0.061	0.061
9	65.92	69.99	14.5	8.0	5.3	0.442	0.063	0.063	0.013	0.013
10	88.88	90.00	11.6	4.3	7.2	0.384	0.041	0.041	0.008	0.008
11	95.09	95.01	10.1	2.6	4.8	0.360	0.017	0.017	0.003	0.003

TABLE X. - Continued. BLADE ELEMENT PERFORMANCE FOR ROTOR 3, 50 PERCENT DESIGN SPEED

(b) Reading 488

RP	RADII		ABS BETAM		REL BETAM		TOTAL TEMP		TOTAL PRESS	
	IN	OUT	IN	OUT	IN	OUT	IN	OUT	IN	OUT
1	9.729	9.578	0.	42.8	66.8	54.0	518.7	550.8	14.69	17.21
2	9.510	9.386	0.	39.4	66.7	53.1	518.7	548.3	14.69	17.22
3	8.598	8.620	0.	39.2	64.9	48.5	518.7	545.0	14.69	17.14
4	8.127	8.237	0.	42.3	63.6	47.0	518.7	545.8	14.69	17.02
5	8.020	8.142	0.	45.2	63.3	47.4	518.7	546.4	14.69	16.91
6	7.893	8.046	0.	49.7	62.9	46.7	518.7	546.6	14.69	16.83
7	7.772	7.950	0.	51.8	62.6	46.1	518.7	546.2	14.69	16.80
8	7.652	7.854	0.	51.4	62.4	43.3	518.7	546.9	14.69	16.84
9	6.665	7.089	0.	40.6	58.9	34.0	518.7	542.6	14.69	17.05
10	5.558	6.323	0.	40.1	55.9	23.0	518.7	541.4	14.69	16.99
11	5.240	6.131	0.	41.7	54.7	16.9	518.7	542.4	14.69	17.11

RP	ABS VEL		REL VEL		MERID VEL		TANG VEL		WHEEL SPEED	
	IN	OUT	IN	OUT	IN	OUT	IN	OUT	IN	OUT
1	293.5	399.3	746.0	498.8	293.5	292.9	0.	271.4	685.9	675.2
2	289.7	398.7	731.6	513.0	289.7	308.1	0.	253.0	671.9	663.1
3	285.0	403.2	670.6	472.1	285.0	312.5	0.	254.8	607.1	608.6
4	285.9	398.3	642.7	431.7	285.9	294.7	0.	267.9	575.7	583.5
5	285.1	390.3	634.8	405.8	285.1	274.8	0.	277.2	567.2	575.8
6	283.9	390.4	623.6	368.7	283.9	252.7	0.	297.6	553.2	566.0
7	283.6	391.5	615.9	349.3	283.6	242.3	0.	307.3	546.7	559.2
8	282.1	403.8	608.3	346.4	282.1	252.1	0.	315.4	538.9	553.1
9	284.3	431.7	550.9	395.1	284.3	327.7	0.	281.1	471.9	501.9
10	265.7	460.9	474.0	383.2	265.7	352.7	0.	296.8	392.5	446.6
11	262.2	485.7	453.6	379.0	262.2	362.7	0.	323.0	370.1	433.1

RP	ABS MACH NO		REL MACH NO		MERID MACH NO		MERID VEL R	PEAK SS MACH NO	EFF
	IN	OUT	IN	OUT	IN	OUT			
1	0.265	0.351	0.673	0.439	0.265	0.258	0.998	0.950	0.744
2	0.261	0.352	0.660	0.452	0.261	0.272	1.064	0.962	0.812
3	0.257	0.357	0.605	0.418	0.257	0.277	1.097	0.973	0.888
4	0.258	0.352	0.580	0.382	0.258	0.261	1.031	0.951	0.822
5	0.257	0.345	0.572	0.358	0.257	0.243	0.964	0.944	0.764
6	0.256	0.345	0.562	0.326	0.256	0.223	0.890	0.929	0.736
7	0.256	0.346	0.555	0.309	0.256	0.214	0.854	0.922	0.734
8	0.254	0.357	0.548	0.306	0.254	0.223	0.894	0.915	0.730
9	0.256	0.384	0.497	0.351	0.256	0.291	1.153	0.834	0.941
10	0.239	0.411	0.427	0.342	0.239	0.314	1.327	0.706	0.971
11	0.236	0.433	0.409	0.338	0.236	0.324	1.383	0.661	0.971

RP	PERCENT SPAN		INCIDENCE		DEV	D-FACT	LOSS COEFF		LOSS PARAM	
	IN	OUT	MEAN	SS			TOT	PROF	TOT	PROF
1	3.19	4.99	5.1	2.8	7.2	0.464	0.194	0.194	0.042	0.042
2	7.68	10.00	6.1	3.6	6.8	0.423	0.138	0.138	0.030	0.030
3	26.33	30.01	9.2	5.1	4.1	0.422	0.086	0.086	0.019	0.019
4	35.99	40.01	10.4	5.5	5.9	0.460	0.151	0.151	0.032	0.032
5	38.18	42.49	10.7	5.6	7.3	0.497	0.208	0.208	0.044	0.044
6	40.78	45.00	10.8	5.7	7.6	0.556	0.242	0.242	0.051	0.051
7	43.25	47.51	11.1	5.7	8.0	0.585	0.246	0.246	0.051	0.051
8	45.71	50.01	11.4	5.9	6.2	0.586	0.262	0.262	0.056	0.056
9	65.92	69.99	12.1	5.5	6.4	0.417	0.059	0.059	0.012	0.012
10	88.58	90.00	11.6	4.3	8.1	0.336	0.037	0.037	0.007	0.007
11	95.09	95.01	10.5	3.1	5.7	0.321	0.041	0.041	0.008	0.008

TABLE X. - Continued. BLADE ELEMENT PERFORMANCE FOR ROTOR 3, 50 PERCENT DESIGN SPEED

(c) Reading 489

RP	RADII		ABS BETAM		REL BETAM		TOTAL TEMP		TOTAL PRESS	
	IN	OUT	IN	OUT	IN	OUT	IN	OUT	IN	OUT
1	9.729	9.578	0.	33.8	64.9	53.3	518.7	545.6	14.69	17.01
2	9.510	9.386	0.	33.3	64.6	52.6	518.7	544.2	14.69	17.00
3	8.598	8.620	0.	34.2	62.1	48.9	518.7	541.9	14.69	16.90
4	8.127	8.237	0.	36.1	60.8	46.3	518.7	543.7	14.69	16.86
5	8.020	8.142	0.	38.2	60.5	46.1	518.7	543.7	14.69	16.78
6	7.893	8.046	0.	42.0	60.2	45.3	518.7	543.6	14.69	16.67
7	7.772	7.950	0.	42.0	59.6	44.9	518.7	543.4	14.69	16.63
8	7.652	7.854	0.	40.1	59.3	43.6	518.7	542.6	14.69	16.69
9	6.665	7.089	0.	36.1	55.9	34.3	518.7	540.6	14.69	16.87
10	5.558	6.323	0.	36.4	53.2	23.2	518.7	540.5	14.69	16.90
11	5.240	6.131	0.	37.6	52.4	18.6	518.7	541.7	14.69	16.96

RP	ABS VEL		REL VEL		MERID VEL		TANG VEL		WHEEL SPEED	
	IN	OUT	IN	OUT	IN	OUT	IN	OUT	IN	OUT
1	320.8	403.5	757.0	561.7	320.8	335.3	0.	224.4	685.6	675.0
2	320.3	404.7	746.1	557.4	320.3	338.4	0.	222.1	673.9	665.1
3	322.3	403.3	688.3	508.0	322.3	333.6	0.	226.6	608.1	609.7
4	321.5	406.6	659.6	476.1	321.5	328.7	0.	239.3	576.0	583.8
5	320.1	400.9	650.6	453.8	320.1	314.8	0.	248.2	566.4	575.0
6	320.0	400.1	643.0	422.9	320.0	297.3	0.	267.7	557.7	568.5
7	321.0	397.6	634.9	417.1	321.0	295.5	0.	265.9	547.8	560.3
8	322.1	404.9	630.3	427.8	322.1	309.6	0.	261.0	541.8	556.1
9	318.1	436.5	567.4	427.7	318.1	352.5	0.	257.5	469.9	499.8
10	294.4	477.5	491.7	417.8	294.4	384.1	0.	283.6	393.9	448.1
11	286.5	496.5	469.3	415.2	286.5	393.6	0.	302.7	371.7	434.9

RP	ABS MACH NO		REL MACH NO		MERID MACH NO		MERID VEL R	PEAK SS MACH NO	EFF
	IN	OUT	IN	OUT	IN	OUT			
1	0.290	0.357	0.684	0.497	0.290	0.297	1.045	0.919	0.823
2	0.289	0.358	0.674	0.494	0.289	0.300	1.056	0.933	0.865
3	0.291	0.358	0.622	0.451	0.291	0.296	1.035	0.943	0.911
4	0.290	0.360	0.596	0.422	0.290	0.291	1.022	0.922	0.832
5	0.289	0.355	0.588	0.402	0.289	0.279	0.984	0.914	0.802
6	0.289	0.354	0.581	0.375	0.289	0.263	0.929	0.905	0.765
7	0.290	0.352	0.574	0.370	0.290	0.262	0.921	0.894	0.756
8	0.291	0.359	0.569	0.379	0.291	0.275	0.961	0.891	0.803
9	0.287	0.389	0.513	0.381	0.287	0.314	1.108	0.808	0.951
10	0.266	0.427	0.444	0.373	0.266	0.343	1.305	0.693	0.971
11	0.258	0.444	0.423	0.371	0.258	0.352	1.374	0.651	0.944

RP	PERCENT SPAN		INCIDENCE		DEV	D-FACT	LOSS COEFF		LOSS PARAM	
	IN	OUT	MEAN	SS			TOT	PROF	TOT	PROF
1	3.19	4.99	3.2	0.9	6.5	0.366	0.112	0.112	0.024	0.024
2	7.68	10.00	4.0	1.5	6.3	0.360	0.083	0.083	0.018	0.018
3	26.35	30.01	6.5	2.3	4.5	0.371	0.058	0.058	0.013	0.013
4	35.99	40.01	7.6	2.7	5.3	0.393	0.126	0.126	0.027	0.027
5	38.18	42.49	7.9	2.8	6.0	0.421	0.152	0.152	0.033	0.033
6	40.78	45.00	8.1	2.9	6.2	0.470	0.184	0.184	0.039	0.039
7	43.25	47.51	8.1	2.8	6.8	0.470	0.193	0.193	0.041	0.041
8	45.71	50.01	8.3	2.8	6.5	0.446	0.153	0.153	0.033	0.033
9	65.92	69.99	9.0	2.5	6.9	0.366	0.043	0.043	0.009	0.009
10	88.58	90.00	8.9	1.6	8.2	0.283	0.033	0.033	0.007	0.007
11	95.09	95.01	8.2	0.8	7.3	0.257	0.073	0.073	0.014	0.014

TABLE X. - Continued. BLADE ELEMENT PERFORMANCE FOR ROTOR 3, 50 PERCENT DESIGN SPEED

(d) Reading 490

RP	RAD II		ABS BETAM		REL BETAM		TOTAL TEMP		TOTAL PRESS	
	IN	OUT	IN	OUT	IN	OUT	IN	OUT	IN	OUT
1	9.729	9.578	0.	25.5	62.6	53.9	518.7	539.8	14.69	16.55
2	9.510	9.386	0.	25.3	62.1	53.0	518.7	539.2	14.69	16.56
3	8.598	8.620	0.	26.3	59.5	49.1	518.7	538.0	14.69	16.53
4	8.127	8.237	0.	29.0	58.0	46.0	518.7	539.5	14.69	16.50
5	8.020	8.142	0.	30.9	57.6	45.5	518.7	540.6	14.69	16.43
6	7.893	8.046	0.	34.0	57.4	45.0	518.7	540.4	14.69	16.32
7	7.772	7.950	0.	32.6	56.8	44.4	518.7	539.6	14.69	16.31
8	7.652	7.854	0.	30.9	56.6	43.1	518.7	539.0	14.69	16.43
9	6.665	7.089	0.	30.0	52.9	34.7	518.7	538.2	14.69	16.64
10	5.558	6.323	0.	31.9	50.2	22.3	518.7	539.4	14.69	16.78
11	5.240	6.131	0.	32.7	49.3	18.6	518.7	540.1	14.69	16.80

RP	ABS VEL		REL VEL		MERID VEL		TANG VEL		WHEEL SPEED	
	IN	OUT	IN	OUT	IN	OUT	IN	OUT	IN	OUT
1	356.8	405.6	774.3	621.1	356.8	366.1	0.	174.8	687.1	676.5
2	354.7	407.3	759.0	611.5	354.7	368.2	0.	174.1	671.1	662.3
3	359.0	412.7	706.7	565.5	359.0	370.1	0.	182.6	608.7	610.2
4	358.8	417.7	676.6	526.4	358.8	365.4	0.	202.4	573.6	581.3
5	358.5	414.5	669.7	507.4	358.5	355.8	0.	212.6	565.7	574.3
6	357.5	409.5	662.8	480.2	357.5	339.3	0.	229.2	558.2	569.0
7	358.3	410.4	653.7	483.8	358.3	345.9	0.	221.0	546.8	559.3
8	357.8	422.6	649.2	496.0	357.8	362.4	0.	217.3	541.7	556.0
9	356.0	456.2	590.5	480.4	356.0	395.2	0.	227.9	471.1	501.1
10	328.0	511.2	512.8	469.4	328.0	434.1	0.	269.9	394.1	448.4
11	318.2	527.0	488.3	468.1	318.2	443.7	0.	284.4	370.4	433.4

RP	ABS MACH NO		REL MACH NO		MERID MACH NO		MERID VEL R	PEAK SS MACH NO	EFF
	IN	OUT	IN	OUT	IN	OUT			
1	0.323	0.361	0.701	0.552	0.323	0.326	1.026	0.881	0.850
2	0.321	0.363	0.687	0.544	0.321	0.328	1.038	0.892	0.879
3	0.325	0.368	0.640	0.504	0.325	0.330	1.031	0.913	0.916
4	0.325	0.372	0.612	0.469	0.325	0.325	1.018	0.888	0.838
5	0.325	0.369	0.606	0.451	0.325	0.316	0.993	0.883	0.769
6	0.324	0.364	0.600	0.427	0.324	0.302	0.949	0.878	0.727
7	0.324	0.365	0.592	0.431	0.324	0.308	0.965	0.865	0.751
8	0.324	0.377	0.588	0.442	0.324	0.323	1.013	0.865	0.827
9	0.322	0.408	0.534	0.429	0.322	0.353	1.110	0.788	0.963
10	0.296	0.458	0.463	0.421	0.296	0.389	1.324	0.677	0.968
11	0.287	0.473	0.441	0.420	0.287	0.398	1.393	0.633	0.946

RP	PERCENT SPAN		INCIDENCE		DEV	D-FACT	LOSS COEFF		LOSS PARAM	
	IN	OUT	MEAN	SS			TOT	PROF	TOT	PROF
1	3.19	4.99	0.8	-1.4	7.1	0.280	0.073	0.073	0.016	0.016
2	7.68	10.00	1.6	-1.0	6.6	0.277	0.059	0.059	0.013	0.013
3	26.35	30.01	3.8	-0.3	4.7	0.285	0.044	0.044	0.009	0.009
4	35.99	40.01	4.7	-0.2	5.0	0.316	0.097	0.097	0.021	0.021
5	38.18	42.49	5.0	-0.1	5.4	0.341	0.148	0.148	0.032	0.032
6	40.78	45.00	5.3	0.1	5.9	0.382	0.176	0.176	0.038	0.038
7	43.25	47.51	5.2	-0.1	6.3	0.363	0.159	0.159	0.034	0.034
8	45.71	50.01	5.6	0.1	6.0	0.336	0.110	0.110	0.024	0.024
9	65.82	69.99	6.0	-0.5	7.0	0.288	0.027	0.027	0.006	0.006
10	88.58	90.00	5.9	-1.4	7.4	0.206	0.032	0.032	0.006	0.006
11	95.09	95.01	5.1	-2.3	7.3	0.169	0.061	0.061	0.012	0.012

TABLE X. - Continued. BLADE ELEMENT PERFORMANCE FOR ROTOR 3, 50 PERCENT DESIGN SPEED

(e) Reading 491

RP	RADII		ABS BETAM		REL BETAM		TOTAL TEMP		TOTAL PRESS	
	IN	OUT	IN	OUT	IN	OUT	IN	OUT	IN	OUT
1	9.729	9.578	0.	20.8	61.2	54.3	518.7	536.7	14.69	16.18
2	9.510	9.386	0.	19.9	60.8	53.4	518.7	535.5	14.69	16.19
3	8.598	8.620	0.	21.2	57.9	49.4	518.7	534.9	14.69	16.20
4	8.127	8.237	0.	23.4	56.3	46.7	518.7	537.0	14.69	16.18
5	8.020	8.142	0.	26.5	55.9	45.8	518.7	537.8	14.69	16.10
6	7.893	8.046	0.	28.7	55.6	45.5	518.7	537.8	14.69	15.97
7	7.772	7.950	0.	27.7	55.2	44.8	518.7	537.6	14.69	16.04
8	7.652	7.854	0.	26.3	54.8	43.1	518.7	537.0	14.69	16.17
9	6.665	7.089	0.	25.6	51.0	34.7	518.7	536.6	14.69	16.45
10	5.558	6.323	0.	29.0	48.7	21.7	518.7	538.5	14.69	16.67
11	5.240	6.131	0.	29.5	47.5	18.5	518.7	539.3	14.69	16.71

RP	ABS VEL		REL VEL		MERID VEL		TANG VEL		WHEEL SPEED	
	IN	OUT	IN	OUT	IN	OUT	IN	OUT	IN	OUT
1	379.1	410.1	786.6	656.3	379.1	383.3	0.	145.7	689.2	678.5
2	377.1	413.6	772.0	652.7	377.1	388.9	0.	140.6	673.6	664.8
3	381.3	421.3	718.3	603.3	381.3	392.8	0.	152.4	608.7	610.3
4	382.3	424.6	689.7	567.7	382.3	389.5	0.	168.9	574.1	581.8
5	383.1	420.5	683.6	539.9	383.1	376.3	0.	187.7	566.1	574.7
6	382.1	413.4	675.7	517.6	382.1	362.5	0.	198.6	557.3	568.1
7	383.1	419.5	671.4	523.4	383.1	371.4	0.	195.3	551.5	564.1
8	383.3	434.4	664.4	533.5	383.3	389.4	0.	192.4	542.8	557.1
9	381.7	474.6	606.7	520.3	381.7	427.8	0.	205.5	471.6	501.6
10	346.5	538.9	525.0	507.5	346.5	471.4	0.	261.0	394.5	448.8
11	340.9	554.9	504.2	509.3	340.9	483.0	0.	273.2	371.5	434.7

RP	ABS MACH NO		REL MACH NO		MERID MACH NO		MERID VEL R	PEAK SS MACH NO	EFF
	IN	OUT	IN	OUT	IN	OUT			
1	0.344	0.366	0.713	0.586	0.344	0.342	1.011	0.858	0.805
2	0.342	0.370	0.700	0.583	0.342	0.348	1.031	0.872	0.866
3	0.346	0.377	0.651	0.540	0.346	0.351	1.030	0.894	0.907
4	0.347	0.379	0.625	0.507	0.347	0.348	1.019	0.871	0.789
5	0.347	0.375	0.620	0.482	0.347	0.336	0.982	0.866	0.717
6	0.346	0.369	0.613	0.462	0.346	0.323	0.949	0.859	0.656
7	0.347	0.374	0.609	0.467	0.347	0.331	0.969	0.858	0.693
8	0.347	0.388	0.602	0.477	0.347	0.348	1.016	0.850	0.783
9	0.346	0.423	0.550	0.466	0.346	0.384	1.121	0.775	0.951
10	0.313	0.485	0.475	0.457	0.313	0.424	1.361	0.669	0.962
11	0.308	0.500	0.456	0.458	0.308	0.435	1.417	0.625	0.942

RP	PERCENT SPAN		INCIDENCE		DEV	D-FACT	LOSS COEFF		LOSS PARAM	
	IN	OUT	MEAN	SS			TOT	PROF	TOT	PROF
1	3.19	4.99	-0.5	-2.8	7.4	0.233	0.078	0.078	0.017	0.017
2	7.68	10.00	0.2	-2.4	7.1	0.220	0.052	0.052	0.011	0.011
3	26.35	30.01	2.3	-1.8	5.0	0.230	0.040	0.040	0.009	0.009
4	35.99	40.01	3.1	-1.8	5.7	0.254	0.108	0.108	0.023	0.023
5	38.18	42.49	3.3	-1.8	5.8	0.296	0.153	0.153	0.033	0.033
6	40.78	45.00	3.5	-1.7	6.4	0.324	0.189	0.189	0.040	0.040
7	43.25	47.51	3.7	-1.7	6.7	0.309	0.170	0.170	0.036	0.036
8	45.71	50.01	3.8	-1.7	6.0	0.284	0.119	0.119	0.026	0.026
9	65.92	69.99	4.1	-2.4	7.1	0.232	0.031	0.031	0.007	0.007
10	88.58	90.00	4.4	-2.9	6.8	0.148	0.035	0.035	0.007	0.007
11	95.09	95.01	3.3	-4.2	7.2	0.109	0.060	0.060	0.011	0.011

TABLE X. - Continued. BLADE ELEMENT PERFORMANCE FOR ROTOR 3, 50 PERCENT DESIGN SPEED

(f) Reading 492

RP	RADII		ABS BETAM		REL BETAM		TOTAL TEMP		TOTAL PRESS	
	IN	OUT	IN	OUT	IN	OUT	IN	OUT	IN	OUT
1	9.729	9.578	0.	13.4	59.5	54.9	518.7	532.1	14.69	15.67
2	9.510	9.386	0.	13.6	59.2	54.1	518.7	531.3	14.69	15.69
3	8.598	8.620	0.	14.1	56.3	50.1	518.7	530.8	14.69	15.77
4	8.127	8.237	0.	17.2	54.6	47.4	518.7	532.6	14.69	15.73
5	8.020	8.142	0.	19.7	54.2	46.9	518.7	534.1	14.69	15.60
6	7.893	8.046	0.	21.6	53.7	46.5	518.7	534.2	14.69	15.46
7	7.772	7.950	0.	22.2	53.4	44.8	518.7	534.7	14.69	15.37
8	7.652	7.854	0.	20.5	52.9	43.3	518.7	534.3	14.69	15.72
9	6.665	7.089	0.	20.1	49.0	34.7	518.7	534.5	14.69	16.20
10	5.558	6.323	0.	24.9	45.8	21.6	518.7	537.4	14.69	16.49
11	5.240	6.131	0.	26.1	45.5	17.7	518.7	538.5	14.69	16.59

RP	ABS VEL		REL VEL		MERID VEL		TANG VEL		WHEEL SPEED	
	IN	OUT	IN	OUT	IN	OUT	IN	OUT	IN	OUT
1	405.4	418.6	798.1	708.5	405.4	407.2	0.	97.0	687.5	676.8
2	402.1	423.2	786.1	700.6	402.1	411.3	0.	99.4	675.4	666.6
3	405.6	435.0	731.3	657.0	405.6	421.8	0.	106.4	608.5	610.1
4	408.9	436.7	705.5	616.2	408.9	417.2	0.	129.2	574.9	582.6
5	409.8	428.7	700.2	591.1	409.8	403.6	0.	144.5	567.8	576.4
6	409.5	420.9	691.3	568.5	409.5	391.2	0.	155.3	556.9	567.7
7	409.5	434.8	686.5	567.1	409.5	402.6	0.	164.2	550.9	563.6
8	409.6	450.7	679.1	580.5	409.6	422.2	0.	157.6	541.7	556.0
9	409.5	504.2	625.8	575.8	409.5	473.6	0.	175.0	470.6	500.5
10	383.3	574.8	549.5	560.5	383.3	521.3	0.	242.0	393.8	448.0
11	364.3	596.1	519.5	562.0	364.3	535.3	0.	262.2	370.3	433.3

RP	ABS MACH NO		REL MACH NO		MERID MACH NO		MERID VEL R	PEAK SS MACH NO	EFF
	IN	OUT	IN	OUT	IN	OUT			
1	0.368	0.375	0.725	0.635	0.368	0.365	1.004	0.818	0.720
2	0.365	0.380	0.714	0.629	0.365	0.369	1.023	0.846	0.780
3	0.368	0.391	0.664	0.591	0.368	0.379	1.040	0.874	0.877
4	0.371	0.392	0.641	0.553	0.371	0.374	1.020	0.853	0.735
5	0.372	0.394	0.636	0.529	0.372	0.361	0.985	0.850	0.579
6	0.372	0.377	0.628	0.509	0.372	0.350	0.955	0.838	0.485
7	0.372	0.389	0.623	0.508	0.372	0.361	0.983	0.838	0.541
8	0.372	0.404	0.617	0.521	0.372	0.379	1.031	0.829	0.646
9	0.372	0.454	0.567	0.519	0.372	0.426	1.157	0.758	0.929
10	0.348	0.519	0.498	0.506	0.348	0.471	1.360	0.650	0.929
11	0.330	0.539	0.470	0.508	0.330	0.484	1.469	0.611	0.925

RP	PERCENT SPAN		INCIDENCE		DEV	D-FACT	LOSS COEFF		LOSS PARAM	
	IN	OUT	MEAN	SS			TOT	PROF	TOT	PROF
1	5.19	4.99	-2.2	-4.5	8.1	0.157	0.082	0.082	0.017	0.017
2	7.68	10.00	-1.3	-3.9	7.7	0.154	0.063	0.063	0.013	0.013
3	26.35	30.01	0.7	-3.4	5.6	0.150	0.038	0.038	0.008	0.008
4	35.99	40.01	1.3	-3.6	6.4	0.184	0.100	0.100	0.021	0.021
5	38.18	42.49	1.5	-3.5	6.9	0.220	0.177	0.177	0.037	0.037
6	40.78	45.00	1.6	-3.6	7.4	0.247	0.222	0.222	0.047	0.047
7	43.25	47.51	1.8	-3.5	6.7	0.247	0.207	0.207	0.044	0.044
8	45.71	50.01	1.9	-3.6	6.3	0.215	0.159	0.159	0.034	0.034
9	65.92	69.99	2.1	-4.4	7.1	0.150	0.038	0.038	0.008	0.008
10	88.58	90.00	1.4	-5.9	6.6	0.082	0.057	0.057	0.011	0.011
11	95.09	95.01	1.3	-6.2	6.8	0.029	0.070	0.070	0.014	0.014

TABLE X. - Concluded. BLADE ELEMENT PERFORMANCE FOR ROTOR 3, 50 PERCENT DESIGN SPEED

(g) Reading 493

RP	RADII		ABS BETAM		REL BETAM		TOTAL TEMP		TOTAL PRESS	
	IN	OUT	IN	OUT	IN	OUT	IN	OUT	IN	OUT
1	0.720	0.570	0.	0.5	50.1	55.0	510.7	525.0	14.60	14.94
2	0.510	0.506	0.	0.5	57.5	54.6	510.7	526.1	14.60	15.03
3	0.500	0.620	0.	6.0	54.6	51.0	510.7	524.7	14.60	15.15
4	0.127	0.237	0.	0.7	52.0	40.0	510.7	527.6	14.60	15.00
5	0.020	0.142	0.	11.1	52.6	40.7	510.7	528.3	14.60	14.92
6	7.093	0.046	0.	14.4	52.1	47.0	510.7	529.7	14.60	14.77
7	7.772	7.050	0.	15.1	51.5	45.7	510.7	530.7	14.60	14.91
8	7.652	7.054	0.	15.3	51.0	45.6	510.7	530.7	14.60	15.14
9	6.655	7.000	0.	15.3	46.0	34.2	510.7	532.5	14.60	15.00
10	5.550	6.523	0.	21.0	44.0	21.2	510.7	536.0	14.60	16.53
11	5.240	6.151	0.	22.2	43.4	17.0	510.7	537.4	14.60	16.40

RP	ABS VEL		REL VEL		MERID VEL		TANG VEL		WHEEL SPEED	
	IN	OUT	IN	OUT	IN	OUT	IN	OUT	IN	OUT
1	429.0	435.5	012.4	770.6	429.0	433.5	0.	41.5	609.3	670.6
2	429.2	446.3	700.7	767.0	429.2	444.4	0.	40.0	674.0	666.0
3	432.6	450.0	747.5	724.0	432.6	456.3	0.	47.0	609.6	611.1
4	434.0	456.0	721.4	603.0	434.0	450.7	0.	60.0	575.6	503.4
5	434.0	440.1	713.1	654.2	434.0	431.0	0.	04.0	567.0	576.4
6	436.0	432.6	709.7	624.0	436.0	410.1	0.	107.3	560.0	570.0
7	436.6	440.7	701.3	620.4	436.6	433.1	0.	117.3	540.0	561.5
8	438.4	470.4	606.0	626.2	438.4	453.7	0.	124.4	541.7	556.0
9	440.3	543.0	644.6	634.5	440.3	524.5	0.	143.6	470.0	500.7
10	407.6	621.5	566.0	622.5	407.6	500.2	0.	222.6	303.0	440.0
11	303.0	641.4	540.5	624.1	303.0	503.0	0.	242.2	371.0	434.1

RP	ABS MACH NO		REL MACH NO		MERID MACH NO		MERID VEL R	PEAK SS MACH NO	EFF
	IN	OUT	IN	OUT	IN	OUT			
1	0.301	0.303	0.750	0.606	0.301	0.302	1.000	0.773	0.342
2	0.300	0.403	0.727	0.603	0.300	0.402	1.036	0.006	0.451
3	0.304	0.416	0.600	0.657	0.304	0.413	1.053	0.032	0.737
4	0.306	0.412	0.656	0.610	0.306	0.407	1.037	0.034	0.430
5	0.306	0.307	0.651	0.500	0.306	0.300	0.993	0.031	0.234
6	0.307	0.300	0.646	0.562	0.307	0.377	0.961	0.026	0.073
7	0.307	0.404	0.630	0.550	0.307	0.300	0.992	0.014	0.100
8	0.309	0.424	0.634	0.564	0.309	0.400	1.035	0.009	0.367
9	0.401	0.402	0.507	0.573	0.401	0.473	1.101	0.740	0.634
10	0.370	0.563	0.513	0.566	0.370	0.527	1.424	0.630	0.026
11	0.337	0.503	0.400	0.560	0.337	0.540	1.311	0.307	0.023

RP	PERCENT SPAN		INCIDENCE		DEV	D-FACT	LOSS COEFF		LOSS PARAM	
	IN	OUT	MEAN	SS			TOT	PROF	TOT	PROF
1	5.10	4.00	-3.7	-0.0	0.0	0.070	0.102	0.102	0.021	0.021
2	7.60	10.00	-3.0	-3.6	0.3	0.030	0.000	0.000	0.010	0.010
3	26.53	30.01	-1.0	-3.1	6.6	0.031	0.036	0.036	0.000	0.000
4	35.00	40.01	-0.3	-3.2	7.7	0.002	0.131	0.131	0.027	0.027
5	30.10	42.40	-0.1	-3.1	0.6	0.122	0.104	0.104	0.040	0.040
6	40.70	45.00	0.0	-3.1	0.7	0.165	0.270	0.270	0.033	0.033
7	43.23	47.51	-0.0	-3.4	7.6	0.166	0.267	0.267	0.036	0.036
8	43.71	50.01	0.0	-3.5	6.5	0.133	0.200	0.200	0.043	0.043
9	63.02	60.00	0.0	-6.0	6.6	0.074	0.064	0.064	0.013	0.013
10	00.00	00.00	-0.3	-7.0	6.3	-0.000	0.032	0.032	0.010	0.010
11	00.00	00.01	-0.0	-0.3	6.7	-0.007	0.064	0.064	0.012	0.012

TABLE XI. - BLADE ELEMENT PERFORMANCE FOR ROTOR 3, 60 PERCENT DESIGN SPEED

(a) Reading 494

RP	RADII		ABS BETAM		REL BETAM		TOTAL TEMP		TOTAL PRESS	
	IN	OUT	IN	OUT	IN	OUT	IN	OUT	IN	OUT
1	9.729	9.578	0.	11.0	59.3	55.3	518.7	533.3	14.69	15.58
2	9.510	9.386	0.	10.4	59.2	54.2	518.7	532.7	14.69	15.66
3	8.598	8.620	0.	10.1	56.2	50.9	518.7	530.8	14.69	15.72
4	8.127	8.237	0.	12.8	54.5	50.3	518.7	533.2	14.69	15.35
5	8.020	8.142	0.	15.4	54.0	50.5	518.7	533.8	14.69	15.03
6	7.893	8.046	0.	17.5	53.6	50.4	518.7	535.7	14.69	14.86
7	7.772	7.950	0.	17.9	53.2	48.0	518.7	536.9	14.69	15.05
8	7.652	7.854	0.	18.3	52.6	44.9	518.7	537.9	14.69	15.42
9	6.665	7.089	0.	17.8	48.7	35.0	518.7	539.4	14.69	16.57
10	5.558	6.323	0.	23.9	45.8	21.4	518.7	545.4	14.69	17.25
11	5.240	6.131	0.	25.4	44.8	18.0	518.7	546.7	14.69	17.43

RP	ABS VEL		REL VEL		MERID VEL		TANG VEL		WHEEL SPEED	
	IN	OUT	IN	OUT	IN	OUT	IN	OUT	IN	OUT
1	485.0	497.3	950.7	861.5	485.0	488.2	0.	95.1	817.7	805.0
2	477.9	511.9	932.1	860.2	477.9	503.5	0.	92.3	800.2	789.8
3	484.5	521.9	870.1	815.6	484.5	513.9	0.	91.2	722.7	724.6
4	487.7	497.0	840.0	758.1	487.7	484.7	0.	110.2	683.8	693.1
5	488.8	475.7	831.9	721.5	488.8	458.6	0.	126.5	673.2	683.5
6	489.4	465.9	824.6	696.8	489.4	444.4	0.	139.9	663.7	676.5
7	488.8	489.9	816.4	697.2	488.8	466.3	0.	150.5	653.9	668.9
8	491.9	524.2	809.4	702.0	491.9	497.7	0.	164.6	642.8	659.8
9	492.8	614.6	747.1	714.4	492.8	585.3	0.	187.6	561.5	597.2
10	455.1	695.9	652.2	683.0	455.1	636.0	0.	282.7	467.2	531.5
11	444.9	715.4	626.7	679.6	444.9	646.4	0.	306.5	441.4	516.5

RP	ABS MACH NO		REL MACH NO		MERID MACH NO		MERID VEL R	PEAK SS MACH NO	EFF
	IN	OUT	IN	OUT	IN	OUT			
1	0.443	0.448	0.868	0.776	0.443	0.440	1.007	0.974	0.597
2	0.436	0.462	0.851	0.776	0.436	0.454	1.053	1.006	0.684
3	0.442	0.472	0.795	0.738	0.442	0.465	1.061	1.041	0.835
4	0.446	0.448	0.767	0.683	0.446	0.437	0.994	1.019	0.451
5	0.446	0.428	0.760	0.649	0.446	0.412	0.938	1.011	0.225
6	0.447	0.418	0.753	0.625	0.447	0.399	0.908	1.004	0.095
7	0.447	0.440	0.746	0.626	0.447	0.418	0.954	0.998	0.195
8	0.449	0.471	0.740	0.631	0.449	0.447	1.012	0.986	0.374
9	0.450	0.556	0.683	0.647	0.450	0.530	1.188	0.987	0.872
10	0.415	0.632	0.594	0.620	0.415	0.577	1.398	0.775	0.911
11	0.405	0.650	0.571	0.618	0.405	0.587	1.453	0.726	0.924

RP	PERCENT SPAN		INCIDENCE		DEV	D-FACT	LOSS COEFF		LOSS PARAM	
	IN	OUT	MEAN	SS			TOT	PROF	TOT	PROF
1	3.19	4.99	-2.4	-4.7	8.6	0.130	0.097	0.097	0.020	0.020
2	7.68	10.00	-1.4	-4.0	7.9	0.113	0.076	0.076	0.016	0.016
3	26.35	30.01	0.5	-3.6	6.5	0.097	0.038	0.038	0.008	0.008
4	35.99	40.01	1.3	-3.6	9.2	0.139	0.160	0.160	0.032	0.032
5	38.18	42.49	1.4	-3.7	10.5	0.180	0.236	0.236	0.046	0.046
6	40.78	45.00	1.5	-3.7	11.2	0.207	0.311	0.311	0.061	0.061
7	43.25	47.51	1.7	-3.7	9.9	0.202	0.302	0.302	0.061	0.061
8	45.71	50.01	1.6	-3.9	7.8	0.184	0.253	0.253	0.053	0.053
9	65.92	69.99	1.8	-4.7	7.4	0.110	0.065	0.065	0.014	0.014
10	88.58	90.00	1.4	-5.9	6.4	0.053	0.074	0.074	0.015	0.015
11	95.09	95.01	0.6	-6.9	6.7	0.023	0.071	0.071	0.014	0.014

TABLE XI. - Continued. BLADE ELEMENT PERFORMANCE FOR ROTOR 3, 60 PERCENT DESIGN SPEED

(b) Reading 496

RP	RADII		ABS BETAM		REL BETAM		TOTAL TEMP		TOTAL PRESS	
	IN	OUT	IN	OUT	IN	OUT	IN	OUT	IN	OUT
1	9.729	9.578	0.	15.6	60.1	54.9	518.7	539.1	14.69	16.32
2	9.510	9.386	0.	15.4	59.8	53.8	518.7	538.2	14.69	16.34
3	8.598	8.620	0.	15.7	56.9	50.3	518.7	536.9	14.69	16.34
4	8.127	8.237	0.	19.6	55.2	48.4	518.7	540.5	14.69	16.15
5	8.020	8.142	0.	21.7	55.0	48.6	518.7	541.2	14.69	15.94
6	7.893	8.046	0.	23.8	54.5	48.1	518.7	541.6	14.69	15.80
7	7.772	7.950	0.	24.2	54.0	46.0	518.7	542.0	14.69	15.97
8	7.652	7.854	0.	23.6	53.6	44.0	518.7	541.8	14.69	16.21
9	6.665	7.089	0.	22.3	49.8	34.9	518.7	542.5	14.69	16.95
10	5.558	6.323	0.	26.9	47.0	21.5	518.7	546.6	14.69	17.41
11	5.240	6.131	0.	28.0	45.4	18.1	518.7	546.8	14.69	17.52

RP	ABS VEL		REL VEL		MERID VEL		TANG VEL		WHEEL SPEED	
	IN	OUT	IN	OUT	IN	OUT	IN	OUT	IN	OUT
1	470.9	490.4	943.9	822.5	470.9	472.4	0.	132.0	818.0	805.3
2	465.6	497.7	924.5	812.7	465.6	479.9	0.	132.3	798.7	788.2
3	470.1	505.0	860.8	761.6	470.1	486.2	0.	136.7	721.1	722.9
4	472.8	494.7	829.4	701.5	472.8	466.0	0.	166.3	681.5	690.7
5	471.9	480.6	822.8	675.3	471.9	446.6	0.	177.7	674.0	684.2
6	474.4	475.9	816.4	652.2	474.4	435.6	0.	191.9	664.4	677.3
7	473.2	492.7	805.6	647.0	473.2	449.6	0.	201.7	652.0	666.9
8	475.1	515.4	800.9	656.3	475.1	472.4	0.	206.2	644.8	661.8
9	474.4	582.4	734.6	656.8	474.4	538.8	0.	221.0	560.9	596.5
10	435.3	660.5	638.2	633.1	435.3	589.0	0.	298.9	466.7	530.9
11	433.5	679.7	617.7	631.4	433.5	600.3	0.	318.8	440.0	514.8

RP	ABS MACH NO		REL MACH NO		MERID MACH NO		MERID VEL R	PEAK SS MACH NO	EFF
	IN	OUT	IN	OUT	IN	OUT			
1	0.430	0.439	0.861	0.737	0.430	0.423	1.003	0.996	0.775
2	0.425	0.446	0.843	0.729	0.425	0.430	1.031	1.017	0.820
3	0.429	0.454	0.785	0.684	0.429	0.437	1.034	1.050	0.877
4	0.431	0.443	0.757	0.628	0.431	0.417	0.986	1.025	0.652
5	0.431	0.429	0.751	0.603	0.431	0.399	0.946	1.025	0.543
6	0.433	0.425	0.745	0.582	0.433	0.389	0.918	1.017	0.475
7	0.432	0.440	0.735	0.578	0.432	0.402	0.950	1.005	0.533
8	0.434	0.461	0.731	0.587	0.434	0.423	0.994	1.001	0.639
9	0.433	0.524	0.670	0.591	0.433	0.485	1.136	0.915	0.907
10	0.396	0.597	0.581	0.572	0.396	0.532	1.353	0.783	0.922
11	0.394	0.615	0.562	0.571	0.394	0.543	1.385	0.729	0.950

RP	PERCENT SPAN		INCIDENCE		DEV	D-FACT	LOSS COEFF		LOSS PARAM	
	IN	OUT	MEAN	SS			TOT	PROF	TOT	PROF
1	3.19	4.99	-1.7	-3.9	8.1	0.180	0.077	0.077	0.016	0.016
2	7.68	10.00	-0.8	-3.4	7.5	0.172	0.060	0.060	0.013	0.013
3	26.35	30.01	1.3	-2.8	5.9	0.168	0.043	0.043	0.009	0.009
4	35.99	40.01	2.0	-2.9	7.3	0.218	0.154	0.154	0.032	0.032
5	38.18	42.49	2.3	-2.7	8.5	0.247	0.209	0.209	0.043	0.043
6	40.78	45.00	2.4	-2.8	8.9	0.274	0.248	0.248	0.051	0.051
7	43.25	47.51	2.5	-2.8	7.9	0.273	0.230	0.230	0.048	0.048
8	45.71	50.01	2.6	-2.9	6.9	0.258	0.179	0.179	0.038	0.038
9	65.92	69.99	2.9	-3.7	7.3	0.185	0.056	0.056	0.012	0.012
10	88.58	90.00	2.6	-4.7	6.6	0.116	0.071	0.071	0.014	0.014
11	95.09	95.01	1.2	-6.2	6.8	0.091	0.049	0.049	0.009	0.009

TABLE XI. - Continued. BLADE ELEMENT PERFORMANCE FOR ROTOR 3, 60 PERCENT DESIGN SPEED

(c) Reading 497

RP	RADII		ABS BETAM		REL BETAM		TOTAL TEMP		TOTAL PRESS	
	IN	OUT	IN	OUT	IN	OUT	IN	OUT	IN	OUT
1	0.720	0.970	0.	22.7	61.9	94.1	910.7	949.9	14.60	17.00
2	0.910	0.966	0.	22.9	61.9	93.4	910.7	944.9	14.60	17.00
3	0.500	0.620	0.	22.7	90.9	40.0	910.7	942.0	14.60	17.04
4	0.127	0.297	0.	26.7	96.0	47.2	910.7	946.1	14.60	16.99
5	0.020	0.142	0.	20.6	96.9	47.0	910.7	946.0	14.60	16.77
6	7.003	0.046	0.	91.4	96.1	46.6	910.7	946.7	14.60	16.62
7	7.772	7.050	0.	90.7	99.7	49.9	910.7	946.4	14.60	16.71
8	7.632	7.004	0.	20.2	99.2	49.2	910.7	949.0	14.60	16.00
9	6.663	7.000	0.	27.7	91.4	94.4	910.7	946.1	14.60	17.99
10	5.550	6.929	0.	90.0	40.6	21.4	910.7	947.0	14.60	17.63
11	5.240	6.191	0.	91.6	47.0	17.0	910.7	949.6	14.60	17.60

RP	ABS VEL		REL VEL		MERID VEL		TANG VEL		WHEEL SPEED	
	IN	OUT	IN	OUT	IN	OUT	IN	OUT	IN	OUT
1	444.6	404.6	091.1	762.0	444.6	447.0	0.	107.9	010.1	005.4
2	430.7	406.1	014.2	793.2	430.7	440.0	0.	106.4	001.6	701.1
3	447.7	491.0	091.0	702.7	447.7	493.5	0.	109.7	724.6	726.5
4	440.0	490.1	010.1	644.9	440.0	497.7	0.	220.7	604.9	699.7
5	447.0	403.2	010.0	622.1	447.0	424.5	0.	291.0	675.5	603.0
6	447.2	476.7	002.0	901.0	447.2	406.7	0.	240.7	665.7	670.6
7	447.9	403.0	709.6	904.9	447.9	417.0	0.	247.0	693.9	670.9
8	446.0	504.1	702.6	605.6	446.0	440.0	0.	246.2	642.4	690.4
9	445.7	554.0	719.0	906.0	445.7	401.5	0.	257.6	990.1	904.7
10	411.1	623.9	622.2	976.0	411.1	996.0	0.	920.6	467.0	991.9
11	907.9	643.0	902.9	978.0	907.9	940.9	0.	997.6	490.2	919.0

RP	ABS MACH NO		REL MACH NO		MERID MACH NO		MERID VEL R	PEAK SS MACH NO	EFF
	IN	OUT	IN	OUT	IN	OUT			
1	0.403	0.491	0.040	0.670	0.403	0.900	1.009	1.090	0.030
2	0.400	0.499	0.092	0.671	0.400	0.400	1.021	1.099	0.001
3	0.400	0.490	0.776	0.627	0.400	0.403	1.019	1.079	0.926
4	0.400	0.496	0.749	0.979	0.400	0.900	0.977	1.040	0.770
5	0.400	0.420	0.790	0.999	0.400	0.977	0.940	1.049	0.700
6	0.407	0.429	0.790	0.926	0.407	0.961	0.910	1.090	0.662
7	0.407	0.492	0.729	0.920	0.407	0.971	0.994	1.090	0.690
8	0.407	0.440	0.719	0.990	0.407	0.902	0.909	1.019	0.779
9	0.406	0.406	0.691	0.999	0.406	0.440	1.109	0.027	0.012
10	0.979	0.962	0.969	0.910	0.979	0.409	1.906	0.709	0.032
11	0.961	0.970	0.990	0.910	0.961	0.409	1.970	0.744	0.019

RP	PERCENT SPAN		INCIDENCE		DEV	D-FACT	LOSS COEFF		LOSS PARAM	
	IN	OUT	MEAN	SS			TOT	PROP	TOT	PROP
1	9.10	4.00	-0.2	-2.9	7.9	0.294	0.060	0.060	0.019	0.019
2	7.60	10.00	0.7	-1.0	7.1	0.240	0.040	0.040	0.010	0.010
3	26.99	90.01	2.7	-1.0	9.4	0.240	0.099	0.099	0.007	0.007
4	99.00	40.01	9.0	-1.4	6.2	0.207	0.129	0.129	0.027	0.027
5	90.10	42.40	9.0	-1.9	6.0	0.921	0.171	0.171	0.099	0.099
6	40.70	49.00	4.0	-1.1	7.4	0.997	0.200	0.200	0.042	0.042
7	49.29	47.91	4.2	-1.2	7.9	0.946	0.100	0.100	0.090	0.090
8	49.71	90.01	4.2	-1.9	6.1	0.929	0.199	0.199	0.020	0.020
9	60.02	60.00	4.0	-2.0	6.0	0.201	0.064	0.064	0.019	0.019
10	00.90	00.00	4.9	-9.0	6.0	0.102	0.047	0.047	0.000	0.000
11	00.00	00.01	9.0	-9.0	6.0	0.109	0.000	0.000	0.010	0.010

TABLE XI. - Continued. BLADE ELEMENT PERFORMANCE FOR ROTOR 3, 60 PERCENT DESIGN SPEED

(d) Reading 498

RP	RADII		ABS BETAM		REL BETAM		TOTAL TEMP		TOTAL PRESS	
	IN	OUT	IN	OUT	IN	OUT	IN	OUT	IN	OUT
1	9.729	9.578	0.	36.0	64.9	55.5	518.7	557.4	14.69	18.16
2	9.510	9.386	0.	34.3	64.6	52.8	518.7	554.8	14.69	18.15
3	8.598	8.620	0.	34.9	62.0	49.0	518.7	552.6	14.69	17.98
4	8.127	8.237	0.	37.5	60.7	46.7	518.7	554.0	14.69	17.86
5	8.020	8.142	0.	40.0	60.5	46.4	518.7	554.5	14.69	17.74
6	7.893	8.046	0.	44.0	60.2	45.6	518.7	554.8	14.69	17.59
7	7.772	7.950	0.	44.9	59.7	44.9	518.7	554.4	14.69	17.54
8	7.652	7.854	0.	42.8	59.4	43.5	518.7	554.0	14.69	17.63
9	6.665	7.089	0.	37.6	55.9	34.2	518.7	550.7	14.69	17.88
10	5.558	6.323	0.	37.8	53.4	22.7	518.7	550.9	14.69	17.91
11	5.240	6.131	0.	38.6	52.2	18.0	518.7	552.7	14.69	18.02

RP	ABS VEL		REL VEL		MERID VEL		TANG VEL		WHEEL SPEED	
	IN	OUT	IN	OUT	IN	OUT	IN	OUT	IN	OUT
1	383.9	479.1	904.5	652.3	383.9	387.6	0.	281.7	819.1	806.3
2	378.8	477.6	884.0	651.9	378.8	394.5	0.	269.3	798.7	788.3
3	383.5	477.9	817.7	596.9	383.5	391.8	0.	273.7	722.1	724.0
4	383.1	477.7	783.5	552.6	383.1	379.2	0.	290.6	683.4	692.6
5	381.7	472.8	774.4	525.1	381.7	362.2	0.	303.8	673.8	684.0
6	380.2	472.8	764.2	486.0	380.2	340.0	0.	328.5	662.9	675.8
7	381.1	472.1	754.7	471.9	381.1	334.4	0.	333.3	651.4	666.3
8	379.0	480.7	745.4	484.1	379.0	352.4	0.	326.9	641.9	658.8
9	378.9	517.6	675.3	495.5	378.9	409.9	0.	316.2	559.0	594.6
10	347.3	562.9	581.8	481.8	347.3	444.6	0.	345.3	466.8	531.0
11	340.3	585.0	555.3	481.0	340.3	457.4	0.	364.7	438.8	513.4

RP	ABS MACH NO		REL MACH NO		MERID MACH NO		MERID VEL R	PEAK SS MACH NO	EFF
	IN	OUT	IN	OUT	IN	OUT			
1	0.348	0.421	0.820	0.574	0.348	0.341	1.010	1.101	0.8551
2	0.343	0.421	0.801	0.575	0.343	0.348	1.041	1.111	0.889
3	0.348	0.422	0.741	0.527	0.348	0.346	1.022	1.122	0.908
4	0.347	0.421	0.710	0.487	0.347	0.334	0.990	1.096	0.843
5	0.346	0.417	0.702	0.463	0.346	0.319	0.949	1.090	0.803
6	0.345	0.417	0.693	0.428	0.345	0.300	0.894	1.080	0.757
7	0.345	0.416	0.684	0.416	0.345	0.295	0.877	1.068	0.753
8	0.344	0.424	0.676	0.427	0.344	0.311	0.930	1.061	0.786
9	0.343	0.459	0.612	0.440	0.343	0.364	1.082	0.964	0.935
10	0.314	0.501	0.526	0.429	0.314	0.396	1.280	0.825	0.938
11	0.308	0.521	0.502	0.429	0.308	0.408	1.344	0.770	0.918

RP	PERCENT SPAN		INCIDENCE		DEV	D-FACT	LOSS COEFF		LOSS PARAM	
	IN	OUT	MEAN	SS			TOT	PROF	TOT	PROF
1	3.19	4.99	3.2	0.9	6.7	0.392	0.110	0.110	0.024	0.024
2	7.68	10.00	4.1	1.5	6.4	0.372	0.072	0.072	0.016	0.016
3	26.35	30.01	6.4	2.3	4.6	0.381	0.064	0.064	0.014	0.014
4	35.99	40.01	7.5	2.6	5.7	0.412	0.122	0.122	0.026	0.026
5	38.18	42.49	7.8	2.8	6.3	0.444	0.158	0.158	0.034	0.034
6	40.78	45.00	8.1	2.9	6.5	0.496	0.199	0.199	0.043	0.043
7	43.25	47.51	8.2	2.8	6.8	0.509	0.205	0.205	0.044	0.044
8	45.71	50.01	8.5	3.0	6.2	0.482	0.180	0.180	0.039	0.039
9	65.82	69.99	9.0	2.5	6.6	0.390	0.060	0.060	0.013	0.013
10	88.58	90.00	9.0	1.7	7.7	0.309	0.076	0.076	0.015	0.015
11	95.09	95.01	8.0	0.6	6.8	0.278	0.115	0.115	0.022	0.022

TABLE XI. - Continued. BLADE ELEMENT PERFORMANCE FOR ROTOR 3, 60 PERCENT DESIGN SPEED

(e) Reading 499

RP	RADII		ABS BETAM		REL BETAM		TOTAL TEMP		TOTAL PRESS	
	IN	OUT	IN	OUT	IN	OUT	IN	OUT	IN	OUT
1	9.729	9.578	0.	41.4	66.7	54.3	518.7	561.7	14.69	18.31
2	9.510	9.386	0.	39.7	66.5	53.1	518.7	559.1	14.69	18.32
3	8.598	8.620	0.	38.9	64.0	48.6	518.7	555.0	14.69	18.22
4	8.127	8.237	0.	42.8	62.9	47.4	518.7	556.3	14.69	18.02
5	8.020	8.142	0.	45.4	62.6	47.3	518.7	557.3	14.69	17.89
6	7.893	8.046	0.	49.6	62.4	47.0	518.7	557.3	14.69	17.75
7	7.772	7.950	0.	51.7	62.0	46.3	518.7	557.4	14.69	17.68
8	7.652	7.854	0.	51.5	61.7	44.1	518.7	557.8	14.69	17.75
9	6.665	7.089	0.	40.6	58.2	35.7	518.7	552.5	14.69	18.10
10	5.558	6.323	0.	40.2	55.0	22.4	518.7	551.6	14.69	18.04
11	5.240	6.131	0.	41.8	54.4	16.4	518.7	553.7	14.69	18.21

RP	ABS VEL		REL VEL		MERID VEL		TANG VEL		WHEEL SPEED	
	IN	OUT	IN	OUT	IN	OUT	IN	OUT	IN	OUT
1	351.7	472.4	889.9	606.3	351.7	354.1	0.	312.7	817.5	804.8
2	347.2	474.0	871.2	607.7	347.2	364.9	0.	302.6	799.0	788.5
3	351.5	478.8	802.4	563.4	351.5	372.7	0.	300.6	721.3	725.2
4	350.5	469.4	769.3	509.5	350.5	344.6	0.	318.8	684.9	694.2
5	349.4	465.3	759.7	481.1	349.4	326.5	0.	331.6	674.6	684.9
6	346.7	465.3	749.4	442.0	346.7	301.7	0.	354.2	664.3	677.2
7	347.4	465.4	739.3	417.8	347.4	288.4	0.	365.2	652.6	667.5
8	347.2	477.4	732.2	413.9	347.2	297.2	0.	373.6	644.7	661.7
9	349.1	516.7	661.8	472.0	349.1	392.6	0.	336.0	562.2	598.0
10	326.3	552.6	569.4	456.4	326.3	422.0	0.	356.8	466.5	530.8
11	315.1	581.2	541.1	451.8	315.1	453.5	0.	387.2	439.9	514.7

RP	ABS MACH NO		REL MACH NO		MERID MACH NO		MERID VEL R	PEAK SS MACH NO	EFF
	IN	OUT	IN	OUT	IN	OUT			
1	0.318	0.414	0.805	0.531	0.318	0.310	1.007	1.133	0.781
2	0.314	0.416	0.788	0.534	0.314	0.321	1.051	1.144	0.857
3	0.318	0.422	0.726	0.497	0.318	0.328	1.060	1.148	0.906
4	0.317	0.413	0.696	0.448	0.317	0.303	0.983	1.125	0.828
5	0.316	0.409	0.687	0.423	0.316	0.287	0.935	1.117	0.778
6	0.314	0.409	0.678	0.388	0.314	0.265	0.870	1.109	0.745
7	0.314	0.409	0.669	0.367	0.314	0.253	0.830	1.096	0.729
8	0.314	0.420	0.662	0.364	0.314	0.261	0.856	1.090	0.736
9	0.316	0.458	0.599	0.418	0.316	0.348	1.124	0.989	0.941
10	0.285	0.492	0.514	0.406	0.285	0.375	1.293	0.833	0.952
11	0.285	0.517	0.489	0.402	0.285	0.386	1.376	0.785	0.938

RP	PERCENT SPAN		INCIDENCE		DEV	D-FACT	LOSS COEFF		LOSS PARAM	
	IN	OUT	MEAN	SS			TOT	PROF	TOT	PROF
1	3.19	4.99	5.0	2.7	7.4	0.447	0.164	0.164	0.035	0.035
2	7.68	10.00	6.0	3.4	6.8	0.427	0.103	0.103	0.022	0.022
3	26.35	30.01	8.4	4.3	4.2	0.422	0.072	0.072	0.016	0.016
4	35.99	40.01	9.7	4.8	6.4	0.468	0.146	0.146	0.031	0.031
5	38.18	42.49	10.0	4.9	7.2	0.503	0.196	0.196	0.041	0.041
6	40.78	45.00	10.4	5.2	7.8	0.556	0.230	0.230	0.048	0.048
7	43.25	47.51	10.5	5.1	8.3	0.585	0.251	0.251	0.052	0.052
8	45.71	50.01	10.7	5.2	7.0	0.588	0.252	0.252	0.054	0.054
9	65.92	69.99	11.3	4.8	6.1	0.420	0.060	0.060	0.013	0.013
10	88.58	90.00	10.7	3.4	7.5	0.343	0.063	0.063	0.013	0.013
11	95.09	95.01	10.2	2.8	5.2	0.322	0.094	0.094	0.018	0.018

TABLE XI. - Concluded. BLADE ELEMENT PERFORMANCE FOR ROTOR 3, 60 PERCENT DESIGN SPEED

(f) Reading 500

RP	RADI		ABS BETAM		REL BETAM		TOTAL TEMP		TOTAL PRESS	
	IN	OUT	IN	OUT	IN	OUT	IN	OUT	IN	OUT
1	9.729	9.578	0.	52.1	68.8	54.8	518.7	568.5	14.69	18.42
2	9.510	9.386	0.	47.2	68.6	53.5	518.7	564.9	14.69	18.41
3	8.598	8.620	0.	41.5	66.3	48.8	518.7	556.5	14.69	18.36
4	8.127	8.257	0.	46.6	65.2	46.9	518.7	557.8	14.69	18.14
5	8.020	8.142	0.	49.6	64.9	47.8	518.7	558.4	14.69	18.00
6	7.893	8.046	0.	54.4	64.5	48.2	518.7	559.0	14.69	17.85
7	7.772	7.950	0.	57.6	64.2	48.5	518.7	559.2	14.69	17.75
8	7.652	7.854	0.	58.2	64.0	46.7	518.7	560.2	14.69	17.79
9	6.665	7.089	0.	42.8	60.2	32.5	518.7	554.0	14.69	18.24
10	5.559	6.323	0.	42.5	55.1	21.8	518.7	551.0	14.69	18.13
11	5.240	6.131	0.	43.6	55.9	15.7	518.7	553.5	14.69	18.33

RP	ABS VEL		REL VEL		MERID VEL		TANG VEL		WHEEL SPEED	
	IN	OUT	IN	OUT	IN	OUT	IN	OUT	IN	OUT
1	318.0	485.2	877.7	517.1	318.0	298.1	0.	382.9	818.1	805.4
2	313.0	477.9	859.4	546.7	313.0	325.0	0.	350.4	800.4	790.0
3	317.7	477.2	789.0	542.1	317.7	357.3	0.	316.4	722.2	724.1
4	315.4	472.7	751.1	475.5	315.4	324.8	0.	343.5	681.6	690.8
5	315.8	464.3	745.1	448.0	315.8	301.1	0.	353.4	674.8	685.1
6	316.1	462.5	735.2	403.3	316.1	269.1	0.	376.2	663.8	676.7
7	314.9	460.4	724.2	371.9	314.9	246.6	0.	388.7	652.2	667.1
8	316.3	471.6	720.4	362.1	316.3	248.4	0.	400.8	647.2	664.3
9	320.7	518.7	644.8	451.6	320.7	380.8	0.	352.2	559.4	595.0
10	327.5	549.3	572.0	436.0	327.5	404.7	0.	371.4	469.0	533.5
11	298.8	578.5	535.2	435.4	298.8	419.1	0.	398.7	441.6	516.7

RP	ABS MACH NO		REL MACH NO		MERID MACH NO		MERID VEL R	PEAK SS MACH NO	EFF
	IN	OUT	IN	OUT	IN	OUT			
1	0.287	0.423	0.783	0.450	0.287	0.260	0.937	1.171	0.694
2	0.283	0.417	0.776	0.477	0.283	0.284	1.038	1.183	0.747
3	0.287	0.420	0.713	0.477	0.287	0.314	1.125	1.181	0.902
4	0.285	0.415	0.678	0.418	0.285	0.285	1.030	1.149	0.824
5	0.285	0.407	0.673	0.393	0.285	0.264	0.953	1.146	0.779
6	0.285	0.406	0.664	0.354	0.285	0.236	0.851	1.134	0.736
7	0.284	0.404	0.654	0.326	0.284	0.216	0.783	1.122	0.711
8	0.286	0.413	0.651	0.317	0.286	0.218	0.786	1.121	0.702
9	0.290	0.459	0.583	0.400	0.290	0.337	1.187	1.003	0.936
10	0.296	0.489	0.517	0.388	0.296	0.360	1.236	0.840	0.995
11	0.270	0.515	0.481	0.387	0.270	0.373	1.403	0.798	0.971

RP	PERCENT SPAN		INCIDENCE		DEV	D-FACT	LOSS COEFF		LOSS PARAM	
	IN	OUT	MEAN	SS			TOT	PROF	TOT	PROF
1	3.19	4.99	7.0	4.8	8.0	0.570	0.264	0.264	0.056	0.056
2	7.68	10.00	8.1	5.5	7.2	0.510	0.213	0.213	0.046	0.046
3	26.35	30.01	10.6	6.5	4.3	0.445	0.081	0.081	0.018	0.018
4	35.99	40.01	11.9	7.0	5.9	0.511	0.161	0.161	0.035	0.035
5	38.18	42.49	12.3	7.2	7.7	0.547	0.207	0.207	0.043	0.043
6	40.78	45.00	12.5	7.3	9.0	0.609	0.256	0.256	0.052	0.052
7	43.25	47.51	12.7	7.4	10.4	0.650	0.289	0.289	0.058	0.058
8	45.71	50.01	13.0	7.5	9.6	0.664	0.307	0.307	0.063	0.063
9	65.92	69.99	13.3	6.8	4.9	0.444	0.071	0.071	0.015	0.015
10	88.58	90.00	10.7	3.4	6.9	0.387	0.007	0.007	0.001	0.001
11	95.09	95.01	11.7	4.3	4.5	0.347	0.045	0.045	0.009	0.009

TABLE XII. - BLADE ELEMENT PERFORMANCE FOR ROTOR 3, 70 PERCENT DESIGN SPEED

(a) Reading 501

RP	RADII		ABS BETAM		REL BETAM		TOTAL TEMP		TOTAL PRESS	
	IN	OUT	IN	OUT	IN	OUT	IN	OUT	IN	OUT
1	0.720	0.570	0.	22.0	61.0	54.3	910.7	951.5	14.60	17.64
2	0.510	0.506	0.	20.0	60.6	53.3	910.7	950.5	14.60	17.66
3	0.590	0.620	0.	21.2	57.0	49.0	910.7	947.5	14.60	17.57
4	0.127	0.297	0.	25.3	56.3	49.2	910.7	950.5	14.60	17.00
5	0.020	0.142	0.	27.2	55.0	50.4	910.7	949.6	14.60	16.51
6	7.093	0.046	0.	20.4	55.5	50.4	910.7	950.5	14.60	16.52
7	7.772	7.950	0.	20.5	55.1	47.0	910.7	953.2	14.60	16.63
8	7.632	7.094	0.	27.3	54.6	45.2	910.7	954.4	14.60	17.04
9	6.663	7.000	0.	26.0	51.0	55.0	910.7	953.7	14.60	16.05
10	5.550	6.523	0.	20.0	40.0	21.0	910.7	950.1	14.60	10.67
11	5.240	6.191	0.	31.4	47.4	17.7	910.7	950.4	14.60	10.00

RP	ABS VEL		REL VEL		KERID VEL		TANG VEL		WHEEL SPEED	
	IN	OUT	IN	OUT	IN	OUT	IN	OUT	IN	OUT
1	520.2	554.6	1091.0	897.4	520.2	523.7	0.	211.1	934.6	939.0
2	525.3	571.2	1069.2	893.4	525.3	534.0	0.	202.9	931.3	919.2
3	530.7	575.2	995.0	832.7	530.7	536.3	0.	207.9	942.7	944.0
4	531.1	547.6	957.0	757.4	531.1	494.0	0.	234.6	797.1	807.9
5	532.1	510.3	940.4	723.4	532.1	461.0	0.	237.7	783.0	797.0
6	530.1	510.1	935.5	704.1	530.1	440.5	0.	243.0	770.0	783.0
7	532.3	537.6	929.6	704.0	532.3	472.5	0.	236.3	762.1	779.6
8	532.7	557.6	910.0	719.6	532.7	504.2	0.	250.6	740.7	760.4
9	520.1	650.1	840.0	713.5	520.1	504.2	0.	203.3	653.4	693.0
10	400.4	731.6	732.0	603.5	400.4	634.3	0.	364.6	344.4	610.4
11	471.1	735.6	605.1	677.4	471.1	645.2	0.	303.3	512.4	590.5

RP	ABS MACH NO		REL MACH NO		KERID MACH NO		KERID VEL R	PEAK SS MACH NO	EFF
	IN	OUT	IN	OUT	IN	OUT			
1	0.404	0.503	1.000	0.790	0.404	0.466	0.091	1.197	0.040
2	0.401	0.500	0.990	0.797	0.401	0.476	1.017	1.214	0.079
3	0.407	0.515	0.913	0.743	0.407	0.400	1.011	1.240	0.043
4	0.407	0.407	0.870	0.674	0.407	0.441	0.932	1.223	0.697
5	0.400	0.462	0.870	0.643	0.400	0.411	0.860	1.213	0.567
6	0.406	0.453	0.850	0.623	0.406	0.390	0.846	1.201	0.493
7	0.400	0.477	0.852	0.623	0.400	0.410	0.800	1.195	0.540
8	0.400	0.504	0.843	0.636	0.400	0.440	0.946	1.182	0.627
9	0.405	0.502	0.771	0.639	0.405	0.523	1.104	1.083	0.097
10	0.447	0.650	0.660	0.615	0.447	0.571	1.206	0.927	0.032
11	0.430	0.601	0.633	0.610	0.430	0.501	1.370	0.860	0.024

RP	PERCENT SPAN		INCIDENCE		DEV	D-FACT	LOSS COEFF		LOSS PARAM	
	IN	OUT	MEAN	SS			TOT	PROF	TOT	PROF
1	3.10	4.00	-0.7	-3.0	7.5	0.240	0.063	0.063	0.014	0.014
2	7.60	10.00	0.0	-2.6	7.0	0.232	0.052	0.050	0.011	0.011
3	26.33	30.01	2.2	-2.0	6.9	0.233	0.023	0.024	0.003	0.003
4	33.00	40.01	3.1	-1.0	0.2	0.207	0.152	0.152	0.031	0.031
5	30.10	42.40	3.2	-1.0	10.4	0.313	0.214	0.214	0.042	0.042
6	40.70	45.00	3.4	-1.0	11.3	0.327	0.261	0.261	0.031	0.031
7	43.23	47.51	3.5	-1.0	0.0	0.326	0.260	0.260	0.032	0.032
8	43.71	30.01	3.6	-1.0	0.1	0.306	0.223	0.223	0.047	0.047
9	60.02	60.00	4.1	-2.4	7.4	0.241	0.072	0.072	0.013	0.013
10	00.00	00.00	3.7	-3.6	6.0	0.101	0.067	0.067	0.014	0.014
11	03.00	03.01	3.2	-4.2	6.0	0.101	0.007	0.007	0.017	0.017

TABLE XII. - Continued. BLADE ELEMENT PERFORMANCE FOR ROTOR 3, 70 PERCENT DESIGN SPEED

(b) Reading 502

RP	RADI		ABS BETAM		REL BETAM		TOTAL TEMP		TOTAL PRESS	
	IN	OUT	IN	OUT	IN	OUT	IN	OUT	IN	OUT
1	0.720	0.570	0.	25.6	61.6	59.6	910.7	930.7	14.60	10.51
2	0.510	0.386	0.	26.1	61.2	52.7	910.7	937.4	14.60	10.50
3	0.500	0.620	0.	25.0	50.5	40.3	910.7	934.3	14.60	10.27
4	0.127	0.297	0.	30.7	57.0	47.6	910.7	936.6	14.60	17.92
5	0.020	0.142	0.	32.4	56.0	40.3	910.7	937.5	14.60	17.50
6	7.093	0.046	0.	34.4	56.3	40.0	910.7	930.2	14.60	17.30
7	7.772	7.050	0.	33.3	55.0	46.3	910.7	930.7	14.60	17.56
8	7.632	7.054	0.	32.1	53.4	44.0	910.7	930.2	14.60	17.03
9	6.663	7.000	0.	30.3	51.0	34.0	910.7	937.5	14.60	10.50
10	5.550	6.323	0.	32.7	40.2	21.0	910.7	930.0	14.60	10.03
11	5.240	6.131	0.	33.0	40.6	17.7	910.7	930.0	14.60	10.03

RP	ABS VEL		REL VEL		MERID VEL		TANG VEL		WHEEL SPEED	
	IN	OUT	IN	OUT	IN	OUT	IN	OUT	IN	OUT
1	514.0	566.7	1003.2	061.6	514.0	511.2	0.	244.0	033.1	030.3
2	512.4	560.4	1063.7	042.6	512.4	510.7	0.	240.7	032.1	010.9
3	516.2	560.0	007.0	705.2	516.2	511.7	0.	240.7	042.2	044.3
4	510.3	557.0	052.6	711.1	510.3	470.6	0.	203.1	700.3	010.1
5	515.3	030.7	040.3	603.3	515.3	434.0	0.	200.3	706.4	700.4
6	516.3	033.1	030.0	637.0	516.3	430.0	0.	301.3	774.4	700.4
7	516.7	540.0	021.2	660.7	516.7	456.0	0.	302.0	762.7	700.1
8	516.7	570.0	011.0	672.1	516.7	403.6	0.	303.4	730.3	770.1
9	514.0	632.6	030.0	663.0	514.0	546.4	0.	310.0	652.7	604.2
10	470.0	707.0	720.0	640.7	470.0	503.0	0.	301.0	544.7	610.6
11	451.7	720.3	603.0	634.1	451.7	604.1	0.	406.7	512.2	300.3

RP	ABS MACH NO		REL MACH NO		MERID MACH NO		MERID VEL R	PEAK SS MACH NO	EFF
	IN	OUT	IN	OUT	IN	OUT			
1	0.471	0.501	0.002	0.762	0.471	0.402	0.003	1.211	0.003
2	0.460	0.504	0.074	0.746	0.460	0.402	0.007	1.220	0.011
3	0.473	0.503	0.004	0.600	0.473	0.403	0.001	1.260	0.033
4	0.475	0.404	0.072	0.630	0.475	0.423	0.023	1.236	0.703
5	0.472	0.476	0.061	0.604	0.472	0.402	0.002	1.220	0.704
6	0.473	0.470	0.052	0.500	0.473	0.300	0.031	1.217	0.643
7	0.473	0.404	0.044	0.304	0.473	0.403	0.004	1.200	0.677
8	0.473	0.503	0.034	0.503	0.473	0.420	0.036	1.196	0.731
9	0.471	0.364	0.761	0.301	0.471	0.407	1.063	1.002	0.000
10	0.430	0.634	0.637	0.374	0.430	0.333	1.263	0.033	0.044
11	0.411	0.634	0.622	0.370	0.411	0.343	1.337	0.077	0.030

RP	PERCENT SPAN		INCIDENCE		DEV	D-FACT	LOSS COEFF		LOSS PARAM	
	IN	OUT	MEAN	SS			TOT	PROF	TOT	PROF
1	3.10	4.00	-0.1	-2.4	6.0	0.207	0.061	0.030	0.013	0.013
2	7.60	10.00	0.6	-1.0	6.4	0.202	0.047	0.044	0.010	0.010
3	26.33	30.01	2.0	-1.3	4.0	0.200	0.033	0.034	0.000	0.007
4	33.00	40.01	3.0	-1.1	6.6	0.340	0.123	0.123	0.026	0.026
5	30.10	42.40	4.1	-1.0	0.2	0.360	0.103	0.103	0.030	0.030
6	40.70	45.00	4.2	-0.0	0.0	0.304	0.220	0.220	0.047	0.047
7	43.23	47.01	4.3	-1.0	0.2	0.303	0.214	0.214	0.043	0.043
8	43.71	00.01	4.4	-1.0	6.0	0.362	0.167	0.167	0.033	0.033
9	00.00	00.00	4.0	-1.6	6.0	0.303	0.072	0.072	0.013	0.013
10	00.00	00.00	4.0	-2.3	6.0	0.232	0.060	0.060	0.012	0.012
11	00.00	00.01	4.4	-3.0	6.4	0.202	0.030	0.030	0.007	0.007

TABLE XII. - Continued. BLADE ELEMENT PERFORMANCE FOR ROTOR 3, 70 PERCENT DESIGN SPEED

(c) Reading 503

RP	RADII		ABS BETAM		REL BETAM		TOTAL TEMP		TOTAL PRESS	
	IN	OUT	IN	OUT	IN	OUT	IN	OUT	IN	OUT
1	9.729	9.578	0.	30.7	62.3	53.2	518.7	563.6	14.69	19.04
2	9.510	9.386	0.	29.9	62.0	52.3	518.7	561.6	14.69	19.03
3	9.598	9.620	0.	30.8	59.5	48.6	518.7	559.6	14.69	18.82
4	9.127	9.237	0.	34.6	58.0	46.4	518.7	551.4	14.69	18.51
5	9.020	9.142	0.	36.4	57.7	47.0	518.7	552.4	14.69	18.30
6	7.893	8.046	0.	38.6	57.3	46.5	518.7	553.0	14.69	18.08
7	7.772	7.950	0.	37.5	56.9	45.6	518.7	551.1	14.69	18.11
8	7.652	7.854	0.	36.3	56.7	43.8	518.7	550.9	14.69	18.39
9	6.665	7.089	0.	33.3	53.1	34.6	518.7	550.3	14.69	18.84
10	5.558	6.323	0.	33.2	50.2	22.2	518.7	550.3	14.69	19.08
11	5.240	6.131	0.	36.6	49.8	17.6	518.7	552.4	14.69	19.23

RP	ABS VEL		REL VEL		MERID VEL		TANG VEL		WHEEL SPEED	
	IN	OUT	IN	OUT	IN	OUT	IN	OUT	IN	OUT
1	500.1	554.1	1074.9	810.0	500.1	485.1	0.	288.0	931.5	936.7
2	494.7	555.9	1053.3	803.1	494.7	490.7	0.	282.1	929.9	917.8
3	496.7	568.1	978.6	738.3	496.7	487.9	0.	291.1	843.1	845.3
4	497.1	561.6	937.0	671.2	497.1	462.5	0.	318.6	794.3	805.0
5	496.6	547.9	930.1	646.8	496.6	441.0	0.	325.2	786.5	798.4
6	496.0	543.4	917.8	616.9	496.0	424.4	0.	339.4	772.2	787.1
7	494.2	546.4	905.3	619.7	494.2	433.2	0.	333.0	758.7	776.1
8	494.1	554.2	898.8	630.7	494.1	454.9	0.	333.8	750.9	770.7
9	490.3	616.9	816.8	624.5	490.3	514.3	0.	340.6	653.3	694.8
10	452.9	680.9	708.2	600.9	452.9	556.4	0.	392.4	544.5	619.4
11	432.8	706.3	671.9	595.0	432.8	567.1	0.	421.1	513.9	601.3

RP	ABS MACH NO		REL MACH NO		MERID MACH NO		MERID VEL R	PEAK SS MACH NO	EFF
	IN	OUT	IN	OUT	IN	OUT			
1	0.457	0.497	0.983	0.713	0.457	0.427	0.970	1.225	0.887
2	0.452	0.498	0.963	0.708	0.452	0.433	0.992	1.244	0.926
3	0.454	0.502	0.893	0.653	0.454	0.431	0.982	1.277	0.930
4	0.454	0.495	0.857	0.592	0.454	0.408	0.931	1.241	0.828
5	0.454	0.482	0.850	0.569	0.454	0.388	0.888	1.241	0.768
6	0.453	0.478	0.839	0.542	0.453	0.373	0.856	1.226	0.714
7	0.452	0.481	0.828	0.546	0.452	0.382	0.877	1.214	0.733
8	0.452	0.498	0.821	0.537	0.452	0.401	0.921	1.212	0.813
9	0.448	0.548	0.746	0.555	0.448	0.457	1.048	1.183	0.938
10	0.413	0.608	0.643	0.537	0.413	0.497	1.228	0.943	0.956
11	0.394	0.631	0.611	0.532	0.394	0.507	1.318	0.889	0.948

RP	PERCENT SPAN		INCIDENCE		DEV	D-FACT	LOSS COEFF		LOSS PARAM	
	IN	OUT	MEAN	SS			TOT	PROF	TOT	PROF
1	9.18	4.98	0.3	-1.7	6.4	0.344	0.066	0.064	0.013	0.014
2	7.68	10.00	1.4	-1.1	6.0	0.334	0.043	0.041	0.010	0.009
3	26.33	30.01	3.8	-0.2	4.2	0.344	0.044	0.043	0.010	0.009
4	33.99	40.01	4.7	-0.2	3.4	0.391	0.120	0.119	0.026	0.026
5	38.18	42.49	3.1	0.0	7.0	0.414	0.163	0.163	0.033	0.033
6	40.78	43.00	3.2	0.0	7.4	0.442	0.210	0.210	0.044	0.044
7	43.23	47.51	3.4	0.0	7.6	0.428	0.179	0.179	0.038	0.038
8	43.71	50.01	3.7	0.2	6.8	0.418	0.138	0.138	0.028	0.028
9	63.82	60.00	6.2	-0.3	6.8	0.343	0.091	0.091	0.011	0.011
10	82.88	80.00	8.8	-1.4	7.3	0.278	0.038	0.038	0.008	0.008
11	83.88	83.01	8.7	-1.7	6.4	0.232	0.066	0.066	0.013	0.013

TABLE XII. - Continued. BLADE ELEMENT PERFORMANCE FOR ROTOR 3, 70 PERCENT DESIGN SPEED

(d) Reading 504

RP	RADII		ABS BETAM		REL BETAM		TOTAL TEMP		TOTAL PRESS	
	IN	OUT	IN	OUT	IN	OUT	IN	OUT	IN	OUT
1	9.729	9.578	0.	33.7	63.2	53.0	518.7	568.7	14.69	19.55
2	9.510	9.386	0.	34.0	63.0	52.1	518.7	566.7	14.69	19.54
3	8.598	8.620	0.	34.2	60.5	48.6	518.7	563.3	14.69	19.25
4	8.127	8.237	0.	37.1	59.2	46.5	518.7	565.2	14.69	18.97
5	8.020	8.142	0.	39.3	58.9	46.3	518.7	566.4	14.69	18.78
6	7.893	8.046	0.	42.8	58.6	46.2	518.7	566.1	14.69	18.55
7	7.772	7.950	0.	43.2	58.1	45.0	518.7	565.9	14.69	18.53
8	7.652	7.854	0.	41.2	57.8	43.4	518.7	564.7	14.69	18.68
9	6.665	7.089	0.	36.8	54.5	34.0	518.7	561.9	14.69	19.12
10	5.558	6.323	0.	37.4	52.0	22.6	518.7	560.9	14.69	19.25
11	5.240	6.131	0.	38.8	51.1	17.5	518.7	563.1	14.69	19.39

RP	ABS VEL		REL VEL		MERID VEL		TANG VEL		WHEEL SPEED	
	IN	OUT	IN	OUT	IN	OUT	IN	OUT	IN	OUT
1	479.5	564.7	1065.3	780.1	479.5	469.6	0.	313.7	951.3	936.6
2	474.4	565.9	1045.6	764.4	474.4	469.3	0.	316.3	931.8	919.7
3	476.1	562.2	967.2	703.0	476.1	464.8	0.	316.6	841.9	844.1
4	473.9	558.1	925.5	646.3	473.9	445.0	0.	337.0	795.0	805.7
5	474.0	552.1	917.4	618.9	474.0	427.3	0.	349.6	785.4	797.4
6	471.6	545.6	905.3	578.4	471.6	400.6	0.	370.5	772.7	787.7
7	471.7	549.0	893.9	566.3	471.7	400.1	0.	376.0	759.3	776.7
8	470.8	561.3	884.5	580.4	470.8	422.0	0.	370.1	748.8	768.6
9	464.3	607.0	799.1	586.8	464.3	486.3	0.	363.3	650.4	691.7
10	425.6	661.4	692.1	569.1	425.6	525.3	0.	402.0	545.7	620.9
11	413.6	687.6	659.3	560.9	413.6	534.9	0.	432.0	513.5	600.8

RP	ABS MACH NO		REL MACH NO		MERID MACH NO		MERID VEL R	PEAK SS MACH NO	EFF
	IN	OUT	IN	OUT	IN	OUT			
1	0.438	0.495	0.972	0.683	0.438	0.411	0.979	1.248	0.881
2	0.433	0.497	0.954	0.671	0.433	0.412	0.989	1.269	0.917
3	0.434	0.495	0.883	0.619	0.434	0.409	0.976	1.291	0.934
4	0.432	0.490	0.844	0.568	0.432	0.391	0.939	1.239	0.845
5	0.433	0.484	0.837	0.543	0.433	0.375	0.902	1.255	0.790
6	0.430	0.478	0.826	0.507	0.430	0.351	0.849	1.244	0.754
7	0.430	0.482	0.816	0.497	0.430	0.351	0.848	1.231	0.754
8	0.429	0.494	0.807	0.510	0.429	0.371	0.896	1.223	0.799
9	0.423	0.537	0.729	0.519	0.423	0.430	1.047	1.113	0.937
10	0.387	0.589	0.629	0.507	0.387	0.468	1.234	0.958	0.986
11	0.376	0.613	0.599	0.500	0.376	0.477	1.293	0.897	0.963

RP	PERCENT SPAN		INCIDENCE		DEV	D-FACT	LOSS COEFF		LOSS PARAM	
	IN	OUT	MEAN	SS			TOT	PROF	TOT	PROF
1	3.19	4.99	1.5	-0.7	6.2	0.375	0.079	0.075	0.017	0.017
2	7.68	10.00	2.3	-0.1	5.8	0.377	0.054	0.051	0.012	0.011
3	26.35	30.01	4.9	0.8	4.2	0.381	0.046	0.044	0.010	0.010
4	35.99	40.01	6.0	1.1	5.5	0.417	0.119	0.118	0.026	0.026
5	38.18	42.49	6.2	1.2	6.3	0.444	0.166	0.166	0.036	0.035
6	40.78	45.00	6.5	1.4	7.0	0.487	0.197	0.197	0.042	0.042
7	43.25	47.51	6.6	1.3	7.0	0.495	0.200	0.200	0.043	0.043
8	45.71	50.01	6.8	1.4	6.3	0.470	0.163	0.163	0.035	0.035
9	65.92	69.99	7.6	1.1	6.4	0.385	0.058	0.058	0.012	0.012
10	88.58	90.00	7.7	0.4	7.7	0.312	0.016	0.016	0.003	0.003
11	95.09	95.01	6.9	-0.5	6.3	0.293	0.050	0.050	0.010	0.010

TABLE XII. - Continued. BLADE ELEMENT PERFORMANCE FOR ROTOR 3, 70 PERCENT DESIGN SPEED

(e) Reading 505

RP	RADII		ABS BETAM		REL BETAM		TOTAL TEMP		TOTAL PRESS	
	IN	OUT	IN	OUT	IN	OUT	IN	OUT	IN	OUT
1	9.729	9.578	0.	37.8	68.0	53.2	918.7	975.4	14.69	19.94
2	9.510	9.386	0.	37.6	64.7	51.8	918.7	971.7	14.69	19.95
3	9.598	9.620	0.	38.4	62.3	48.6	918.7	967.2	14.69	19.62
4	9.127	8.237	0.	42.2	61.2	47.3	918.7	968.2	14.69	19.23
5	9.020	8.142	0.	45.1	61.0	47.0	918.7	969.1	14.69	19.03
6	7.893	8.046	0.	48.8	60.6	46.6	918.7	970.1	14.69	18.86
7	7.772	7.950	0.	50.6	60.5	45.7	918.7	970.9	14.69	18.83
8	7.652	7.834	0.	49.5	60.1	43.2	918.7	970.5	14.69	18.93
9	6.663	7.089	0.	40.0	56.5	33.3	918.7	965.1	14.69	19.42
10	5.558	6.323	0.	40.3	53.5	22.1	918.7	961.9	14.69	19.40
11	5.240	6.131	0.	41.4	52.9	16.6	918.7	965.7	14.69	19.39

RP	ABS VEL		REL VEL		MERID VEL		TANG VEL		WHEEL SPEED	
	IN	OUT	IN	OUT	IN	OUT	IN	OUT	IN	OUT
1	444.8	562.8	1052.0	741.5	444.8	444.6	0.	345.1	933.4	938.6
2	439.8	568.0	1028.9	727.1	439.8	449.9	0.	346.8	930.1	918.0
3	441.8	560.0	951.3	663.4	441.8	439.1	0.	347.6	842.7	844.9
4	437.9	547.1	908.1	597.6	437.9	405.5	0.	367.3	795.3	806.3
5	433.1	543.8	896.8	561.8	433.1	383.8	0.	385.8	784.2	785.1
6	433.8	542.6	883.8	519.9	433.8	357.1	0.	408.3	771.4	786.4
7	430.8	547.4	873.8	497.7	430.8	347.6	0.	422.9	761.6	779.8
8	430.3	561.4	864.3	388.6	430.3	365.8	0.	426.6	749.3	769.3
9	431.7	603.6	782.3	554.9	431.7	462.7	0.	387.8	652.7	694.2
10	402.3	647.3	676.7	533.2	402.3	494.1	0.	418.4	544.8	618.8
11	386.7	676.6	641.2	529.8	386.7	507.8	0.	447.1	511.3	598.3

RP	ABS MACH NO		REL MACH NO		MERID MACH NO		MERID VEL R	PEAK SS MACH NO	EFF
	IN	OUT	IN	OUT	IN	OUT			
1	0.403	0.490	0.958	0.646	0.403	0.397	0.999	1.289	0.833
2	0.400	0.496	0.936	0.636	0.400	0.393	1.023	1.300	0.896
3	0.402	0.491	0.866	0.582	0.402	0.388	0.994	1.320	0.922
4	0.398	0.479	0.826	0.523	0.398	0.383	0.926	1.287	0.836
5	0.396	0.475	0.816	0.491	0.396	0.385	0.880	1.281	0.790
6	0.393	0.474	0.805	0.454	0.393	0.312	0.823	1.269	0.747
7	0.392	0.478	0.796	0.433	0.392	0.304	0.807	1.263	0.733
8	0.392	0.491	0.786	0.438	0.392	0.319	0.848	1.252	0.733
9	0.393	0.533	0.712	0.490	0.393	0.408	1.072	1.137	0.927
10	0.363	0.573	0.614	0.474	0.363	0.439	1.228	0.856	0.891
11	0.331	0.601	0.581	0.471	0.331	0.431	1.313	0.803	0.843

RP	PERCENT SPAN		INCIDENCE		DEV	D-FACT	LOSS COEFF		LOSS PARAM	
	IN	OUT	MEAN	SS			TOT	PROF	TOT	PARAM
1	3.18	4.09	3.3	1.0	6.3	0.413	0.124	0.118	0.027	0.026
2	7.68	10.00	4.1	1.6	8.4	0.414	0.076	0.072	0.017	0.016
3	26.33	30.01	6.7	2.6	4.1	0.424	0.060	0.037	0.013	0.013
4	35.99	40.01	7.9	3.8	6.3	0.479	0.137	0.136	0.029	0.029
5	38.18	42.49	8.3	3.3	7.8	0.507	0.181	0.181	0.039	0.039
6	40.78	43.00	8.6	3.4	7.3	0.333	0.226	0.226	0.047	0.047
7	43.23	47.31	8.8	3.6	7.6	0.378	0.246	0.246	0.032	0.032
8	43.71	50.01	8.1	3.7	8.1	0.338	0.220	0.220	0.038	0.038
9	63.82	69.00	8.7	3.1	8.8	0.421	0.073	0.073	0.016	0.016
10	88.33	90.00	8.2	1.8	7.1	0.333	0.012	0.012	0.002	0.002
11	83.88	83.01	8.7	1.3	8.4	0.323	0.002	0.002	0.016	0.016

TABLE XII. - Continued. BLADE ELEMENT PERFORMANCE FOR ROTOR 3, 70 PERCENT DESIGN SPEED

(f) Reading 507

RP	RADII		ABS BETAM		REL BETAM		TOTAL TEMP		TOTAL PRESS	
	IN	OUT	IN	OUT	IN	OUT	IN	OUT	IN	OUT
1	9.729	9.578	0.	45.6	67.5	54.5	518.7	579.7	14.69	19.87
2	9.510	9.566	0.	43.5	67.3	53.1	518.7	577.1	14.69	19.95
3	8.598	8.620	0.	41.7	65.0	48.8	518.7	571.0	14.69	19.77
4	8.127	8.237	0.	47.0	63.8	47.0	518.7	571.3	14.69	19.42
5	8.020	8.142	0.	49.5	63.8	47.9	518.7	572.0	14.69	19.16
6	7.893	8.046	0.	54.2	63.6	48.1	518.7	572.6	14.69	18.99
7	7.772	7.950	0.	57.5	63.1	48.4	518.7	573.8	14.69	18.89
8	7.652	7.854	0.	58.0	62.9	45.9	518.7	574.6	14.69	18.96
9	6.665	7.089	0.	42.6	59.2	32.0	518.7	567.2	14.69	19.71
10	5.558	6.323	0.	42.0	55.8	22.0	518.7	563.0	14.69	19.49
11	5.240	6.131	0.	43.3	55.0	15.7	518.7	567.5	14.69	19.76

RP	ABS VEL		REL VEL		MERID VEL		TANG VEL		WHEEL SPEED	
	IN	OUT	IN	OUT	IN	OUT	IN	OUT	IN	OUT
1	394.8	552.8	1031.1	666.4	394.8	386.8	0.	395.0	952.5	937.7
2	390.4	555.2	1010.2	671.6	390.4	402.8	0.	382.1	931.7	919.5
3	392.6	556.1	929.4	630.3	392.6	415.0	0.	370.2	842.4	844.5
4	390.7	550.6	886.0	550.9	390.7	375.4	0.	402.8	795.2	806.0
5	385.9	537.8	873.9	521.6	385.9	349.5	0.	408.7	784.1	796.0
6	383.4	538.0	861.9	470.7	383.4	314.4	0.	436.6	772.0	786.9
7	385.3	536.9	852.2	434.5	385.3	288.6	0.	452.8	760.2	777.6
8	384.3	551.8	843.0	421.0	384.3	292.8	0.	467.7	750.4	770.2
9	390.4	611.4	761.7	530.7	390.4	449.8	0.	414.1	654.1	695.7
10	371.4	640.2	660.3	513.2	371.4	475.7	0.	428.4	545.9	621.0
11	359.1	675.0	626.8	509.8	359.1	490.9	0.	463.3	513.7	601.1

RP	ABS MACH NO		REL MACH NO		MERID MACH NO		MERID VEL R	PEAK SS MACH NO	EFF
	IN	OUT	IN	OUT	IN	OUT			
1	0.358	0.479	0.935	0.578	0.358	0.335	0.980	1.341	0.765
2	0.354	0.482	0.916	0.584	0.354	0.350	1.032	1.353	0.811
3	0.356	0.486	0.843	0.551	0.356	0.363	1.057	1.362	0.877
4	0.354	0.481	0.804	0.481	0.354	0.328	0.961	1.325	0.819
5	0.350	0.469	0.792	0.455	0.350	0.305	0.906	1.320	0.765
6	0.348	0.469	0.781	0.410	0.348	0.274	0.820	1.309	0.731
7	0.349	0.467	0.773	0.378	0.349	0.251	0.749	1.297	0.700
8	0.348	0.480	0.764	0.367	0.348	0.255	0.762	1.289	0.701
9	0.354	0.539	0.691	0.468	0.354	0.396	1.152	1.165	0.936
10	0.337	0.568	0.598	0.455	0.337	0.422	1.281	0.986	0.986
11	0.325	0.598	0.567	0.452	0.325	0.435	1.367	0.924	0.940

RP	PERCENT SPAN		INCIDENCE		DEV	D-FACT	LOSS COEFF		LOSS PARAM	
	IN	OUT	MEAN	SS			TOT	PROF	TOT	PROF
1	3.19	4.99	5.8	3.5	7.7	0.493	0.192	0.186	0.041	0.040
2	7.68	10.00	6.7	4.1	6.8	0.471	0.154	0.148	0.033	0.032
3	26.33	30.01	9.4	5.3	4.4	0.453	0.105	0.102	0.023	0.022
4	35.99	40.01	10.6	5.7	6.0	0.522	0.166	0.165	0.036	0.035
5	38.18	42.49	11.1	6.1	7.9	0.549	0.222	0.221	0.046	0.046
6	40.78	45.00	11.3	6.3	8.9	0.610	0.262	0.261	0.053	0.053
7	43.25	47.51	11.6	6.3	10.3	0.652	0.302	0.302	0.060	0.060
8	45.71	50.01	11.9	6.4	8.9	0.667	0.310	0.310	0.064	0.064
9	65.92	69.99	12.3	5.8	4.4	0.446	0.071	0.071	0.015	0.015
10	88.58	90.00	11.4	4.1	7.1	0.372	0.019	0.019	0.004	0.004
11	95.09	95.01	10.8	3.4	4.5	0.349	0.097	0.097	0.019	0.019

TABLE XII. - Concluded. BLADE ELEMENT PERFORMANCE FOR ROTOR 3, 70 PERCENT DESIGN SPEED

(g) Reading 538

RP	RADI I		ABS BETAM		REL BETAM		TOTAL TEMP		TOTAL PRESS	
	IN	OUT	IN	OUT	IN	OUT	IN	OUT	IN	OUT
1	9.729	9.578	0.	54.0	69.9	54.6	518.7	592.2	14.69	20.14
2	9.510	9.386	0.	50.7	69.6	53.7	518.7	587.1	14.69	20.08
3	8.598	8.620	0.	47.9	67.6	49.0	518.7	576.5	14.69	19.85
4	8.127	8.237	0.	52.6	66.9	47.7	518.7	577.2	14.69	19.54
5	8.020	8.142	0.	54.8	66.8	48.8	518.7	578.0	14.69	19.36
6	7.893	8.046	0.	60.2	66.6	50.6	518.7	577.7	14.69	19.14
7	7.772	7.950	0.	65.1	66.2	52.9	518.7	578.5	14.69	18.95
8	7.652	7.854	0.	66.4	66.0	51.7	518.7	578.2	14.69	18.94
9	6.665	7.089	0.	46.7	61.6	29.8	518.7	571.7	14.69	19.86
10	5.558	6.323	0.	43.9	57.9	20.8	518.7	565.8	14.69	19.62
11	5.240	6.131	0.	44.9	57.1	14.8	518.7	567.5	14.69	19.90

RP	ABS VEL		REL VEL		MERID VEL		TANG VEL		WHEEL SPEED	
	IN	OUT	IN	OUT	IN	OUT	IN	OUT	IN	OUT
1	350.7	574.7	1018.1	584.0	350.7	338.1	0.	464.8	955.8	941.0
2	348.3	563.5	997.4	603.4	348.3	357.0	0.	436.0	934.6	922.5
3	348.5	560.8	916.1	573.8	348.5	376.1	0.	416.0	847.2	849.4
4	340.1	553.7	868.5	500.1	340.1	336.3	0.	439.9	799.1	809.9
5	339.2	543.1	859.6	475.5	339.2	313.0	0.	443.8	789.8	801.8
6	335.8	537.8	846.2	421.0	335.8	267.3	0.	466.6	776.7	791.8
7	337.3	534.1	834.9	372.0	337.3	224.8	0.	484.6	763.8	781.3
8	334.8	543.3	824.2	350.7	334.8	217.5	0.	497.8	753.1	773.0
9	355.8	623.3	746.9	492.5	355.8	427.4	0.	453.7	656.7	698.5
10	343.7	644.9	646.9	497.0	343.7	464.7	0.	447.2	548.0	623.4
11	333.4	676.7	614.5	495.7	333.4	479.4	0.	477.6	516.2	604.0

RP	ABS MACH NO		REL MACH NO		MERID MACH NO		MERID VEL R	PEAK SS MACH NO	EFF
	IN	OUT	IN	OUT	IN	OUT			
1	0.317	0.493	0.921	0.501	0.317	0.290	0.964	1.394	0.665
2	0.315	0.486	0.902	0.520	0.315	0.308	1.025	1.403	0.707
3	0.315	0.488	0.829	0.499	0.315	0.327	1.079	1.413	0.806
4	0.308	0.481	0.785	0.434	0.308	0.292	0.989	1.378	0.752
5	0.307	0.471	0.777	0.412	0.307	0.271	0.923	1.373	0.717
6	0.304	0.466	0.765	0.365	0.304	0.232	0.796	1.361	0.690
7	0.305	0.463	0.755	0.322	0.305	0.194	0.665	1.346	0.654
8	0.303	0.471	0.745	0.304	0.303	0.189	0.650	1.337	0.657
9	0.322	0.548	0.676	0.433	0.322	0.375	1.201	1.196	0.879
10	0.311	0.571	0.585	0.440	0.311	0.411	1.352	1.007	0.948
11	0.301	0.600	0.556	0.440	0.301	0.428	1.438	0.945	0.962

RP	PERCENT SPAN		INCIDENCE		DEV	D-FACT	LOSS COEFF		LOSS PARAM	
	IN	OUT	MEAN	SS			TOT	PROF	TOT	PROF
1	3.19	4.99	8.1	5.9	7.8	0.593	0.322	0.313	0.069	0.067
2	7.68	10.00	9.0	6.4	7.4	0.552	0.276	0.267	0.059	0.057
3	26.35	30.01	12.0	7.9	4.6	0.524	0.184	0.179	0.040	0.039
4	35.99	40.01	13.7	8.8	6.7	0.584	0.258	0.256	0.054	0.054
5	38.18	42.49	14.1	9.1	8.8	0.608	0.301	0.299	0.061	0.061
6	40.78	45.00	14.6	9.4	11.4	0.672	0.333	0.334	0.065	0.065
7	43.25	47.51	14.7	9.3	14.8	0.731	0.386	0.385	0.070	0.070
8	45.71	50.01	15.1	9.6	14.6	0.756	0.390	0.389	0.072	0.072
9	65.82	69.99	14.7	8.2	2.2	0.501	0.151	0.151	0.033	0.033
10	88.58	90.00	13.6	6.3	5.9	0.391	0.076	0.076	0.015	0.015
11	95.09	95.01	12.9	5.5	3.6	0.364	0.063	0.063	0.012	0.012

TABLE XIII. - BLADE ELEMENT PERFORMANCE FOR ROTOR 3, 80 PERCENT DESIGN SPEED

(a) Reading 513

RP	RADII		ABS BETAM		REL BETAM		TOTAL TEMP		TOTAL PRESS	
	IN	OUT	IN	OUT	IN	OUT	IN	OUT	IN	OUT
1	9.729	9.578	0.	29.3	61.2	53.7	518.7	575.7	14.69	19.84
2	9.510	9.386	0.	28.2	60.9	53.0	518.7	573.0	14.69	19.87
3	8.598	8.620	0.	27.9	58.2	49.0	518.7	570.0	14.69	19.69
4	8.127	8.237	0.	34.2	56.5	49.7	518.7	571.1	14.69	18.58
5	8.020	8.142	0.	35.5	56.3	51.3	518.7	569.7	14.69	17.97
6	7.893	8.046	0.	36.8	55.9	51.3	518.7	569.3	14.69	17.79
7	7.772	7.950	0.	35.5	55.5	48.4	518.7	571.0	14.69	18.19
8	7.652	7.854	0.	34.0	55.1	45.0	518.7	570.3	14.69	18.75
9	6.665	7.089	0.	31.2	51.6	35.3	518.7	569.2	14.69	19.79
10	5.558	6.323	0.	34.6	49.4	21.8	518.7	573.0	14.69	20.40
11	5.240	6.131	0.	35.7	48.6	17.8	518.7	575.7	14.69	20.56

RP	ABS VEL		REL VEL		MERID VEL		TANG VEL		WHEEL SPEED	
	IN	OUT	IN	OUT	IN	OUT	IN	OUT	IN	OUT
1	601.8	641.2	1248.0	945.8	601.8	559.3	0.	313.7	1093.4	1076.4
2	593.7	641.0	1221.6	940.0	593.7	565.1	0.	302.5	1067.6	1053.7
3	600.2	652.6	1137.6	879.0	600.2	576.7	0.	305.4	966.4	968.9
4	602.8	601.1	1093.5	769.1	602.8	497.2	0.	338.0	912.4	924.7
5	601.1	572.3	1082.1	744.9	601.1	466.0	0.	332.4	899.8	913.4
6	600.2	565.5	1070.8	724.1	600.2	452.8	0.	338.9	886.8	904.0
7	600.7	596.4	1059.8	730.9	600.7	485.4	0.	346.7	873.2	893.2
8	600.0	634.9	1047.8	744.2	600.0	526.2	0.	355.4	859.0	881.6
9	593.5	708.9	955.3	742.4	593.5	606.2	0.	367.5	748.6	796.2
10	534.1	791.2	821.4	701.8	534.1	651.6	0.	449.3	624.1	710.0
11	518.7	815.1	784.0	695.6	518.7	662.3	0.	475.2	587.9	687.9

RP	ABS MACH NO		REL MACH NO		MERID MACH NO		MERID VEL R	PEAK SS MACH NO	EFF
	IN	OUT	IN	OUT	IN	OUT			
1	0.555	0.562	1.152	0.829	0.555	0.490	0.929	1.297	0.815
2	0.548	0.563	1.127	0.826	0.548	0.497	0.932	1.322	0.860
3	0.554	0.576	1.050	0.776	0.554	0.509	0.961	1.398	0.881
4	0.556	0.527	1.009	0.675	0.556	0.436	0.825	1.401	0.687
5	0.555	0.501	0.999	0.653	0.555	0.408	0.775	1.407	0.602
6	0.554	0.495	0.988	0.634	0.554	0.397	0.754	1.398	0.575
7	0.554	0.523	0.978	0.641	0.554	0.426	0.808	1.386	0.625
8	0.554	0.559	0.967	0.655	0.554	0.463	0.877	1.373	0.725
9	0.547	0.630	0.881	0.660	0.547	0.539	1.022	1.259	0.913
10	0.490	0.707	0.753	0.627	0.490	0.582	1.220	1.080	0.939
11	0.475	0.729	0.718	0.622	0.475	0.592	1.277	1.011	0.916

RP	PERCENT SPAN		INCIDENCE		DEV	D-FACT	LOSS COEFF		LOSS PARAM	
	IN	OUT	MEAN	SS			TOT	PROF	TOT	PROF
1	3.19	4.99	-0.5	-2.8	6.9	0.334	0.110	0.093	0.024	0.020
2	7.68	10.00	0.4	-2.2	6.7	0.319	0.082	0.065	0.018	0.014
3	26.35	30.01	2.5	-1.6	4.6	0.316	0.074	0.055	0.016	0.012
4	35.99	40.01	3.3	-1.6	8.7	0.394	0.205	0.189	0.042	0.038
5	38.18	42.49	3.6	-1.4	11.2	0.407	0.256	0.240	0.050	0.046
6	40.78	45.00	3.8	-1.3	12.1	0.421	0.276	0.262	0.053	0.050
7	43.25	47.51	3.9	-1.4	10.3	0.410	0.256	0.244	0.051	0.049
8	45.71	50.01	4.0	-1.4	7.9	0.392	0.191	0.181	0.040	0.038
9	65.92	69.99	4.7	-1.8	7.7	0.324	0.070	0.069	0.015	0.014
10	88.58	90.00	5.1	-2.2	6.9	0.272	0.068	0.068	0.014	0.014
11	95.89	95.01	4.4	-3.1	6.6	0.246	0.107	0.107	0.021	0.021

TABLE XIII. - Continued. BLADE ELEMENT PERFORMANCE FOR ROTOR 3, 80 PERCENT DESIGN SPEED

(b) Reading 515

RP	RADII		ABS BETAM		REL BETAM		TOTAL TEMP		TOTAL PRESS	
	IN	OUT	IN	OUT	IN	OUT	IN	OUT	IN	OUT
1	0.720	0.570	0.	35.5	62.0	52.0	510.7	507.1	14.60	21.20
2	0.510	0.306	0.	34.5	61.0	52.0	510.7	502.0	14.60	21.25
3	0.500	0.620	0.	34.4	59.0	47.0	510.7	570.0	14.60	20.95
4	0.127	0.237	0.	30.5	57.6	46.7	510.7	500.1	14.60	20.16
5	0.020	0.142	0.	40.7	57.3	48.6	510.7	570.0	14.60	19.60
6	7.093	0.046	0.	42.3	56.0	48.5	510.7	570.1	14.60	19.47
7	7.772	7.050	0.	41.0	56.5	46.7	510.7	577.0	14.60	19.61
8	7.632	7.094	0.	39.2	56.1	44.1	510.7	577.1	14.60	19.07
9	6.663	7.000	0.	36.3	52.7	35.3	510.7	573.0	14.60	20.43
10	5.550	6.323	0.	37.4	50.1	22.6	510.7	576.0	14.60	20.73
11	5.240	6.131	0.	30.7	49.4	17.0	510.7	578.0	14.60	20.09

RP	ABS VEL		REL VEL		MERID VEL		TANG VEL		WHEEL SPEED	
	IN	OUT	IN	OUT	IN	OUT	IN	OUT	IN	OUT
1	579.0	649.1	1235.5	074.3	579.0	528.2	0.	377.4	1091.0	1074.0
2	571.0	649.7	1211.7	070.2	571.0	535.3	0.	368.3	1068.3	1054.4
3	500.5	656.0	1128.2	007.0	500.5	542.2	0.	371.0	057.4	059.9
4	579.5	635.1	1001.2	715.4	570.5	490.2	0.	404.1	012.0	025.1
5	577.3	604.0	1060.0	603.2	577.3	450.5	0.	394.6	000.0	014.5
6	576.0	590.7	1057.5	668.2	576.0	442.0	0.	403.0	006.3	003.3
7	575.7	611.1	1044.2	673.2	575.7	461.3	0.	400.0	071.2	091.2
8	577.2	630.3	1035.6	608.6	577.2	494.6	0.	403.4	059.0	002.6
9	570.2	604.4	040.0	675.6	570.2	551.3	0.	405.5	740.5	705.1
10	521.2	736.5	012.5	651.3	521.2	601.3	0.	450.0	623.3	709.1
11	504.1	704.3	774.6	643.5	504.1	612.2	0.	490.1	500.2	600.2

RP	ABS MACH NO		REL MACH NO		MERID MACH NO		MERID VEL R	PEAK SS MACH NO	EFF
	IN	OUT	IN	OUT	IN	OUT			
1	0.534	0.564	1.130	0.750	0.534	0.450	0.911	1.316	0.046
2	0.526	0.566	1.115	0.750	0.526	0.467	0.936	1.347	0.097
3	0.535	0.575	1.030	0.707	0.535	0.474	0.934	1.423	0.003
4	0.534	0.554	0.906	0.624	0.534	0.420	0.846	1.430	0.790
5	0.532	0.527	0.905	0.604	0.532	0.390	0.704	1.424	0.732
6	0.531	0.522	0.974	0.502	0.531	0.306	0.760	1.412	0.730
7	0.530	0.533	0.961	0.507	0.530	0.403	0.801	1.390	0.735
8	0.531	0.550	0.934	0.603	0.531	0.433	0.857	1.300	0.813
9	0.523	0.604	0.866	0.506	0.523	0.406	0.867	1.270	0.933
10	0.477	0.671	0.744	0.370	0.477	0.334	1.134	1.004	0.930
11	0.461	0.607	0.700	0.372	0.461	0.344	1.215	1.010	0.913

RP	PERCENT SPAN		INCIDENCE		DEV	D-FACT	LOSS COEFF		LOSS PARAM	
	IN	OUT	MEAN	SS			TOT	PROF	TOT	PROF
1	3.10	4.00	0.3	-2.0	6.0	0.404	0.100	0.001	0.024	0.020
2	7.60	10.00	1.3	-1.3	5.7	0.391	0.072	0.032	0.016	0.012
3	26.33	30.01	3.4	-0.7	3.4	0.393	0.072	0.030	0.016	0.011
4	53.00	40.01	4.3	-0.6	5.7	0.436	0.137	0.130	0.034	0.030
5	30.10	42.40	4.7	-0.4	0.5	0.467	0.101	0.173	0.030	0.035
6	40.70	45.00	4.0	-0.3	0.3	0.463	0.200	0.103	0.042	0.030
7	43.23	47.31	3.0	-0.3	0.7	0.472	0.103	0.101	0.040	0.037
8	45.71	50.01	3.1	-0.4	7.0	0.432	0.140	0.130	0.032	0.020
9	63.02	60.00	3.0	-0.7	7.7	0.303	0.060	0.030	0.012	0.012
10	00.00	00.00	3.7	-1.6	7.7	0.320	0.073	0.073	0.015	0.015
11	03.00	03.01	0.2	-2.2	0.7	0.300	0.117	0.117	0.023	0.023

TABLE XIII. - Continued. BLADE ELEMENT PERFORMANCE FOR ROTOR 3, 80 PERCENT DESIGN SPEED

(c) Reading 517

RP	RADII		ABS BETAM		REL BETAM		TOTAL TEMP		TOTAL PRESS	
	IN	OUT	IN	OUT	IN	OUT	IN	OUT	IN	OUT
1	9.729	9.578	0.	39.1	63.0	52.9	518.7	592.2	14.69	21.91
2	9.510	9.386	0.	37.8	62.7	52.1	518.7	589.2	14.69	21.84
3	8.598	8.620	0.	37.5	60.0	47.8	518.7	583.7	14.69	21.53
4	8.127	8.237	0.	41.6	58.7	46.3	518.7	585.0	14.69	20.89
5	8.020	8.142	0.	43.6	58.4	47.3	518.7	584.7	14.69	20.46
6	7.893	8.046	0.	45.6	58.1	47.2	518.7	583.4	14.69	20.27
7	7.772	7.950	0.	44.6	57.7	45.9	518.7	581.8	14.69	20.25
8	7.652	7.854	0.	42.7	57.3	43.8	518.7	580.8	14.69	20.43
9	6.665	7.089	0.	38.0	54.0	52.0	518.7	575.8	14.69	20.78
10	5.558	6.323	0.	39.3	51.6	29.6	518.7	577.0	14.69	20.97
11	5.240	6.131	0.	40.9	51.3	20.0	518.7	580.5	14.69	21.16

RP	ABS VEL		REL VEL		MERID VEL		TANG VEL		WHEEL SPEED	
	IN	OUT	IN	OUT	IN	OUT	IN	OUT	IN	OUT
1	556.3	649.4	1225.6	835.0	556.3	504.2	0.	409.5	1092.1	1075.1
2	550.1	646.9	1200.0	831.9	550.1	511.4	0.	396.4	1066.5	1052.6
3	557.9	653.7	1116.7	772.1	557.9	518.7	0.	397.9	967.4	969.8
4	555.8	639.6	1069.4	692.4	555.8	478.1	0.	425.1	913.6	926.0
5	555.6	621.0	1059.2	662.7	555.6	449.5	0.	428.5	901.8	915.5
6	553.6	616.0	1047.2	635.0	553.6	431.2	0.	440.0	888.8	906.1
7	552.4	620.6	1032.6	634.8	552.4	441.5	0.	436.3	872.4	892.4
8	551.3	636.8	1019.8	648.2	551.3	467.9	0.	432.0	858.0	880.6
9	544.0	490.2	925.4	618.8	544.0	381.0	0.	308.6	748.6	796.2
10	495.0	661.1	796.3	588.9	495.0	511.8	0.	418.4	623.8	709.6
11	472.8	742.0	755.6	597.3	472.8	561.3	0.	485.4	589.4	689.7

RP	ABS MACH NO		REL MACH NO		MERID MACH NO		MERID VEL R	PEAK SS MACH NO	EFF
	IN	OUT	IN	OUT	IN	OUT			
1	0.511	0.561	1.126	0.722	0.511	0.436	0.906	1.342	0.853
2	0.505	0.561	1.102	0.721	0.505	0.443	0.930	1.368	0.881
3	0.513	0.570	1.026	0.673	0.513	0.452	0.930	1.452	0.921
4	0.511	0.556	0.983	0.602	0.511	0.416	0.860	1.448	0.827
5	0.510	0.539	0.973	0.575	0.510	0.390	0.809	1.441	0.780
6	0.509	0.535	0.962	0.551	0.509	0.375	0.779	1.433	0.771
7	0.507	0.540	0.949	0.552	0.507	0.384	0.799	1.415	0.789
8	0.506	0.555	0.937	0.565	0.506	0.408	0.849	1.401	0.828
9	0.499	0.424	0.849	0.536	0.499	0.330	0.700	1.283	0.947
10	0.452	0.580	0.728	0.517	0.452	0.449	1.034	1.096	0.931
11	0.431	0.655	0.689	0.527	0.431	0.495	1.187	1.033	0.921

RP	PERCENT SPAN		INCIDENCE		DEV	D-FACT	LOSS COEFF		LOSS PARAM	
	IN	OUT	MEAN	SS			TOT	PROF	TOT	PROF
1	3.19	4.99	1.3	-1.0	6.0	0.440	0.112	0.092	0.025	0.020
2	7.68	10.00	2.2	-0.4	5.7	0.425	0.090	0.070	0.020	0.015
3	26.35	30.01	4.4	-0.3	3.4	0.426	0.063	0.039	0.014	0.009
4	35.99	40.01	5.4	0.5	5.3	0.478	0.147	0.128	0.032	0.028
5	38.18	42.49	5.7	0.6	7.2	0.500	0.187	0.170	0.039	0.036
6	40.78	45.00	6.0	0.8	8.1	0.523	0.196	0.180	0.041	0.037
7	43.25	47.51	6.1	0.8	7.9	0.514	0.180	0.167	0.038	0.033
8	45.71	50.01	6.3	0.8	6.7	0.492	0.149	0.138	0.032	0.030
9	65.92	69.99	7.1	0.6	24.4	0.419	0.051	0.030	0.008	0.008
10	88.58	90.00	7.2	-0.1	14.6	0.382	0.061	0.061	0.012	0.012
11	95.09	95.01	7.1	-0.4	8.7	0.350	0.114	0.114	0.022	0.022

TABLE XIII. - Continued. BLADE ELEMENT PERFORMANCE FOR ROTOR 3, 80 PERCENT DESIGN SPEED

(d) Reading 518

RP	RADII		ABS BETAM		REL BETAM		TOTAL TEMP		TOTAL PRESS	
	IN	OUT	IN	OUT	IN	OUT	IN	OUT	IN	OUT
1	0.729	0.570	0.	41.7	64.0	52.5	510.7	506.0	14.69	22.29
2	0.510	0.386	0.	40.0	64.6	51.6	510.7	503.6	14.69	22.26
3	0.500	0.620	0.	40.3	61.0	48.9	510.7	505.4	14.69	21.50
4	0.127	0.237	0.	45.6	60.0	47.3	510.7	500.4	14.69	21.03
5	0.020	0.142	0.	40.1	60.7	47.5	510.7	500.9	14.69	20.73
6	7.093	0.046	0.	52.4	60.4	47.4	510.7	509.7	14.69	20.46
7	7.772	7.050	0.	54.2	60.1	46.6	510.7	500.6	14.69	20.43
8	7.652	7.054	0.	53.2	59.0	43.9	510.7	500.3	14.69	20.30
9	6.665	7.000	0.	42.6	56.4	33.3	510.7	500.7	14.69	21.23
10	5.550	6.323	0.	42.0	53.6	22.1	510.7	570.0	14.69	21.10
11	5.240	6.151	0.	43.5	52.6	15.6	510.7	503.6	14.69	21.53

RP	ABS VEL		REL VEL		MERID VEL		TANG VEL		WHEEL SPEED	
	IN	OUT	IN	OUT	IN	OUT	IN	OUT	IN	OUT
1	513.3	655.6	1206.5	804.0	513.3	489.7	0.	436.1	1091.0	1074.0
2	508.6	655.3	1104.5	799.6	508.6	496.1	0.	428.7	1069.7	1055.0
3	515.0	636.6	1095.4	730.4	515.0	485.3	0.	412.3	956.3	950.0
4	509.3	629.5	1046.6	640.6	509.3	440.1	0.	450.2	914.4	926.7
5	505.0	620.0	1033.1	613.0	505.0	414.0	0.	461.9	900.0	914.3
6	504.0	620.0	1019.4	559.0	504.0	370.7	0.	490.9	886.1	903.2
7	503.1	625.3	1008.5	532.0	503.1	366.2	0.	507.1	874.1	894.1
8	499.0	641.6	995.0	532.0	499.0	304.2	0.	513.0	860.4	883.1
9	498.3	607.1	999.0	604.6	498.3	305.6	0.	465.4	749.4	797.0
10	462.0	733.3	777.6	500.5	462.0	345.3	0.	490.3	625.3	711.6
11	450.5	773.0	741.1	501.0	450.5	360.6	0.	532.2	580.4	608.3

RP	ABS MACH NO		REL MACH NO		MERID MACH NO		MERID VEL R	PEAK SS MACH NO	EFF
	IN	OUT	IN	OUT	IN	OUT			
1	0.470	0.563	1.104	0.603	0.470	0.422	0.954	1.390	0.039
2	0.463	0.566	1.004	0.601	0.463	0.420	0.976	1.420	0.073
3	0.472	0.553	1.003	0.641	0.472	0.422	0.941	1.310	0.903
4	0.466	0.543	0.950	0.562	0.466	0.301	0.864	1.403	0.003
5	0.463	0.537	0.945	0.531	0.463	0.359	0.820	1.474	0.763
6	0.461	0.536	0.932	0.404	0.461	0.327	0.731	1.461	0.723
7	0.460	0.540	0.922	0.460	0.460	0.316	0.720	1.452	0.712
8	0.457	0.555	0.910	0.461	0.457	0.332	0.769	1.440	0.733
9	0.456	0.602	0.823	0.530	0.456	0.443	1.013	1.310	0.927
10	0.421	0.647	0.709	0.520	0.421	0.401	1.100	1.116	0.040
11	0.410	0.602	0.673	0.514	0.410	0.403	1.244	1.043	0.024

RP	PERCENT SPAN		INCIDENCE		DEV	D-FACT	LOSS COEFF		LOSS PARAM	
	IN	OUT	MEAN	SS			TOT	PROF	TOT	PROF
1	3.10	4.00	3.1	0.0	0.7	0.463	0.133	0.100	0.030	0.024
2	7.60	10.00	4.0	1.4	0.3	0.483	0.103	0.070	0.023	0.017
3	26.33	30.01	6.3	2.2	4.5	0.450	0.001	0.032	0.010	0.011
4	35.00	40.01	7.6	2.7	6.3	0.516	0.100	0.130	0.030	0.034
5	30.10	42.40	0.0	3.0	7.4	0.345	0.221	0.203	0.046	0.042
6	40.70	45.00	0.3	3.1	0.3	0.300	0.263	0.247	0.034	0.031
7	43.23	47.31	0.3	3.2	0.3	0.623	0.203	0.260	0.030	0.033
8	43.71	50.01	0.0	3.4	6.0	0.620	0.207	0.233	0.037	0.034
9	63.02	60.00	0.3	3.0	0.7	0.464	0.070	0.077	0.017	0.016
10	00.00	00.00	0.2	1.0	7.2	0.300	0.060	0.060	0.014	0.014
11	00.00	00.01	0.4	0.0	4.4	0.372	0.110	0.110	0.023	0.023

TABLE XIII. - Continued. BLADE ELEMENT PERFORMANCE FOR ROTOR 3, 80 PERCENT DESIGN SPEED

(e) Reading 539

RP	RADII		ABS BETAM		REL BETAM		TOTAL TEMP		TOTAL PRESS	
	IN	OUT	IN	OUT	IN	OUT	IN	OUT	IN	OUT
1	9.729	9.578	0.	44.1	66.5	52.5	518.7	602.7	14.69	22.32
2	9.510	9.586	0.	42.0	66.0	51.7	518.7	597.0	14.69	22.30
3	8.598	8.620	0.	43.1	63.6	49.5	518.7	587.8	14.69	21.45
4	8.127	8.257	0.	48.6	62.7	47.6	518.7	591.2	14.69	21.10
5	8.020	8.142	0.	51.2	62.6	47.6	518.7	592.1	14.69	20.85
6	7.895	8.046	0.	56.2	62.5	49.0	518.7	592.5	14.69	20.44
7	7.772	7.950	0.	59.5	62.1	48.9	518.7	593.2	14.69	20.37
8	7.652	7.854	0.	59.5	61.8	46.5	518.7	593.7	14.69	20.45
9	6.665	7.089	0.	45.9	58.1	52.2	518.7	582.5	14.69	21.38
10	5.558	6.525	0.	45.0	55.5	21.8	518.7	578.7	14.69	21.17
11	5.240	6.131	0.	44.2	54.1	15.7	518.7	583.6	14.69	21.51

RP	ABS VEL		REL VEL		MERID VEL		TANG VEL		WHEEL SPEED	
	IN	OUT	IN	OUT	IN	OUT	IN	OUT	IN	OUT
1	479.5	658.4	1191.5	775.8	479.5	472.6	0.	458.6	1090.8	1073.9
2	475.3	654.4	1169.5	785.8	475.3	486.7	0.	437.7	1068.5	1054.6
3	478.8	629.8	1077.7	707.5	478.8	459.9	0.	430.4	965.5	968.0
4	470.8	628.6	1027.9	615.7	470.8	415.5	0.	471.8	913.8	926.1
5	466.4	625.6	1013.4	578.8	466.4	390.6	0.	486.2	899.7	913.4
6	464.2	613.5	999.7	519.9	464.2	340.9	0.	510.1	885.4	902.6
7	462.0	618.8	988.2	479.9	462.0	315.8	0.	532.2	873.6	893.6
8	461.5	632.2	976.1	467.8	461.5	322.3	0.	543.8	860.2	882.9
9	466.0	693.0	880.8	589.7	466.0	499.1	0.	480.8	747.5	795.0
10	431.5	728.9	758.9	574.5	431.5	533.4	0.	496.8	624.3	710.2
11	425.5	765.8	726.0	570.4	425.5	549.0	0.	535.8	588.4	688.5

RP	ABS MACH NO		REL MACH NO		MERID MACH NO		MERID VEL R	PEAK SS MACH NO	EFF
	IN	OUT	IN	OUT	IN	OUT			
1	0.438	0.564	1.088	0.665	0.438	0.405	0.986	1.429	0.783
2	0.434	0.564	1.067	0.677	0.434	0.419	1.024	1.460	0.839
3	0.437	0.546	0.984	0.613	0.437	0.398	0.960	1.542	0.857
4	0.429	0.543	0.958	0.552	0.429	0.359	0.882	1.511	0.779
5	0.425	0.538	0.924	0.499	0.425	0.337	0.837	1.501	0.743
6	0.423	0.528	0.911	0.448	0.423	0.294	0.734	1.489	0.695
7	0.421	0.535	0.901	0.413	0.421	0.272	0.684	1.481	0.681
8	0.421	0.545	0.890	0.405	0.421	0.278	0.698	1.467	0.685
9	0.425	0.607	0.803	0.517	0.425	0.437	1.071	1.324	0.919
10	0.392	0.643	0.690	0.507	0.392	0.471	1.236	1.128	0.950
11	0.387	0.676	0.660	0.503	0.387	0.484	1.291	1.055	0.918

RP	PERCENT SPAN		INCIDENCE		DEV	D-FACT	LOSS COEFF		LOSS PARAM	
	IN	OUT	MEAN	SS			TOT	PROF	TOT	PROF
1	3.19	4.99	4.5	2.5	5.7	0.489	0.191	0.164	0.043	0.037
2	7.68	10.00	5.5	2.9	5.4	0.462	0.139	0.110	0.031	0.025
3	26.35	30.01	8.0	3.9	5.0	0.476	0.125	0.093	0.027	0.020
4	35.99	40.01	9.5	4.6	6.5	0.546	0.214	0.192	0.045	0.041
5	38.18	42.49	9.9	4.9	7.5	0.578	0.256	0.256	0.053	0.049
6	40.78	45.00	10.3	5.1	9.9	0.637	0.310	0.292	0.062	0.058
7	43.25	47.51	10.6	5.3	10.8	0.678	0.331	0.315	0.066	0.062
8	45.71	50.01	10.8	5.3	9.4	0.688	0.337	0.323	0.069	0.066
9	65.02	69.99	11.2	4.7	4.6	0.474	0.092	0.091	0.020	0.020
10	88.58	90.00	11.0	3.7	6.9	0.394	0.070	0.070	0.014	0.014
11	95.09	95.01	9.9	2.5	4.5	0.375	0.133	0.133	0.026	0.026

TABLE XIII. - Continued. BLADE ELEMENT PERFORMANCE FOR ROTOR 3, 80 PERCENT DESIGN SPEED

(f) Reading 540

RP	RADII		ABS BETAM		REL BETAM		TOTAL TEMP		TOTAL PRESS	
	IN	OUT	IN	OUT	IN	OUT	IN	OUT	IN	OUT
1	9.729	9.578	0.	47.3	68.2	52.6	518.7	609.1	14.69	22.37
2	9.510	9.386	0.	45.4	68.0	52.0	518.7	601.0	14.69	22.33
3	8.598	8.620	0.	48.0	65.8	49.6	518.7	591.8	14.69	21.50
4	8.127	8.237	0.	52.3	65.3	47.2	518.7	595.5	14.69	21.20
5	8.020	8.142	0.	55.6	65.2	47.6	518.7	596.6	14.69	21.00
6	7.893	8.046	0.	60.7	65.1	49.8	518.7	596.2	14.69	20.62
7	7.772	7.950	0.	65.2	64.7	51.5	518.7	595.9	14.69	20.41
8	7.652	7.854	0.	66.2	64.4	50.6	518.7	596.4	14.69	20.35
9	6.665	7.089	0.	46.2	60.3	29.8	518.7	586.6	14.69	21.51
10	5.558	6.323	0.	44.1	57.0	20.6	518.7	579.8	14.69	21.24
11	5.240	6.131	0.	45.3	56.4	14.6	518.7	583.7	14.69	21.66

RP	ABS VEL		REL VEL		MERID VEL		TANG VEL		WHEEL SPEED	
	IN	OUT	IN	OUT	IN	OUT	IN	OUT	IN	OUT
1	437.0	662.7	1176.7	740.2	437.0	449.3	0.	487.3	1092.5	1075.5
2	431.6	655.0	1152.4	746.1	431.6	459.6	0.	466.8	1068.5	1054.6
3	433.0	632.0	1056.9	652.7	433.0	423.0	0.	469.6	964.2	966.6
4	420.1	636.8	1004.6	573.1	420.1	389.1	0.	504.2	912.6	924.9
5	416.1	632.5	990.8	530.1	416.1	357.7	0.	521.6	899.2	912.8
6	411.8	622.1	976.3	471.3	411.8	304.4	0.	542.6	885.2	902.4
7	412.4	621.5	964.3	418.5	412.4	260.6	0.	564.2	871.7	891.7
8	411.0	625.8	951.3	398.2	411.0	252.5	0.	572.6	857.9	880.6
9	426.0	711.1	860.3	566.8	426.0	492.0	0.	513.5	747.4	794.9
10	404.7	734.0	743.5	562.9	404.7	526.8	0.	511.2	623.7	709.5
11	391.6	770.7	707.2	560.5	391.6	542.4	0.	547.5	588.8	689.0

RP	ABS MACH NO		REL MACH NO		MERID MACH NO		MERID VEL R	PEAK SS MACH NO	EFF
	IN	OUT	IN	OUT	IN	OUT			
1	0.398	0.565	1.071	0.631	0.398	0.383	1.028	1.485	0.733
2	0.393	0.562	1.048	0.640	0.393	0.394	1.063	1.518	0.800
3	0.394	0.546	0.961	0.563	0.394	0.365	0.977	1.579	0.816
4	0.382	0.548	0.913	0.493	0.382	0.335	0.926	1.550	0.746
5	0.378	0.544	0.900	0.456	0.378	0.307	0.860	1.541	0.715
6	0.374	0.534	0.887	0.405	0.374	0.261	0.739	1.530	0.680
7	0.375	0.534	0.876	0.360	0.375	0.224	0.632	1.516	0.661
8	0.373	0.538	0.864	0.342	0.373	0.217	0.614	1.502	0.650
9	0.387	0.622	0.782	0.496	0.387	0.430	1.155	1.350	0.879
10	0.367	0.647	0.675	0.497	0.367	0.465	1.302	1.142	0.942
11	0.355	0.680	0.641	0.495	0.355	0.479	1.385	1.074	0.936

RP	PERCENT SPAN		INCIDENCE		DEV	D-FACT	LOSS COEFF		LOSS PARAM	
	IN	OUT	MEAN	SS			TOT	PROF	TOT	PROF
1	3.19	4.99	6.5	4.2	5.8	0.522	0.252	0.219	0.056	0.049
2	7.68	10.00	7.4	4.9	5.6	0.498	0.182	0.147	0.041	0.033
3	26.35	30.01	10.2	6.1	5.2	0.529	0.173	0.138	0.037	0.030
4	35.89	40.01	12.0	7.1	6.2	0.588	0.267	0.241	0.037	0.031
5	38.18	42.49	12.5	7.5	7.5	0.629	0.308	0.285	0.064	0.060
6	40.78	45.00	13.0	7.8	10.6	0.688	0.350	0.330	0.069	0.065
7	43.25	47.51	13.2	7.8	13.4	0.744	0.376	0.359	0.071	0.067
8	45.71	50.01	13.4	8.0	13.6	0.762	0.398	0.384	0.075	0.072
9	65.82	69.99	13.5	6.9	2.2	0.498	0.151	0.150	0.033	0.033
10	88.58	90.00	12.7	5.4	5.7	0.401	0.086	0.086	0.017	0.017
11	95.09	95.01	12.2	4.8	3.4	0.377	0.110	0.110	0.022	0.022

TABLE XIII. - Concluded. BLADE ELEMENT PERFORMANCE FOR ROTOR 3, 80 PERCENT DESIGN SPEED

(g) Reading 541

RP	RADII		ABS BETAM		REL BETAM		TOTAL TEMP		TOTAL PRESS	
	IN	OUT	IN	OUT	IN	OUT	IN	OUT	IN	OUT
1	9.729	9.578	0.	53.6	70.4	54.3	518.7	614.1	14.69	22.23
2	9.510	9.386	0.	49.4	70.0	52.8	518.7	607.4	14.69	22.18
3	8.598	8.620	0.	51.1	68.2	49.0	518.7	597.4	14.69	21.60
4	8.127	8.237	0.	55.6	67.7	47.1	518.7	599.3	14.69	21.28
5	8.020	8.142	0.	59.1	67.6	47.2	518.7	600.0	14.69	21.10
6	7.893	8.046	0.	63.9	67.5	49.1	518.7	599.6	14.69	20.82
7	7.772	7.950	0.	69.4	67.3	54.7	518.7	599.1	14.69	20.46
8	7.652	7.854	0.	71.5	67.0	55.4	518.7	599.3	14.69	20.37
9	6.665	7.089	0.	51.3	62.5	25.7	518.7	590.6	14.69	21.54
10	5.558	6.323	0.	44.5	59.1	20.0	518.7	580.3	14.69	21.28
11	5.240	6.131	0.	45.6	57.6	14.0	518.7	583.1	14.69	21.70

RP	ABS VEL		REL VEL		MERID VEL		TANG VEL		WHEEL SPEED	
	IN	OUT	IN	OUT	IN	OUT	IN	OUT	IN	OUT
1	388.1	660.1	1159.6	670.3	388.1	391.4	0.	531.7	1092.8	1075.8
2	388.0	651.5	1136.4	701.7	388.0	423.8	0.	494.9	1068.1	1054.2
3	385.6	644.7	1038.5	616.4	385.6	404.8	0.	501.9	964.3	966.7
4	373.7	644.6	985.0	534.4	373.7	363.7	0.	532.2	911.4	923.7
5	370.6	646.7	973.1	488.5	370.6	351.9	0.	555.0	899.8	913.5
6	365.7	641.4	957.5	431.6	365.7	282.5	0.	575.8	885.0	902.1
7	364.1	622.5	944.4	378.1	364.1	218.6	0.	582.9	871.4	891.3
8	364.8	626.1	932.4	348.7	364.8	198.2	0.	593.9	858.1	880.7
9	388.9	735.3	842.7	510.3	388.9	459.8	0.	573.8	747.6	795.2
10	373.3	739.7	727.4	561.0	373.3	527.3	0.	518.7	624.2	710.2
11	372.4	772.8	695.4	556.8	372.4	540.2	0.	552.6	587.3	687.2

RP	ABS MACH NO		REL MACH NO		MERID MACH NO		MERID VEL R	PEAK SS MACH NO	EFF
	IN	OUT	IN	OUT	IN	OUT			
1	0.352	0.560	1.052	0.569	0.352	0.332	1.009	1.551	0.682
2	0.352	0.556	1.031	0.599	0.352	0.362	1.092	1.579	0.730
3	0.350	0.554	0.942	0.530	0.350	0.348	1.050	1.623	0.766
4	0.339	0.553	0.892	0.459	0.339	0.312	0.973	1.589	0.718
5	0.336	0.555	0.882	0.419	0.336	0.285	0.895	1.583	0.695
6	0.331	0.550	0.867	0.370	0.331	0.242	0.773	1.571	0.671
7	0.330	0.533	0.855	0.324	0.330	0.187	0.600	1.558	0.640
8	0.330	0.537	0.844	0.299	0.330	0.170	0.543	1.543	0.630
9	0.353	0.642	0.764	0.446	0.353	0.402	1.183	1.377	0.833
10	0.338	0.653	0.659	0.495	0.338	0.465	1.413	1.162	0.940
11	0.337	0.683	0.630	0.492	0.337	0.477	1.451	1.082	0.949

RP	PERCENT SPAN		INCIDENCE		DEV	D-FACT	LOSS COEFF		LOSS PARAM	
	IN	OUT	MEAN	SS			TOT	PROF	TOT	PROF
1	3.19	4.99	8.7	6.3	7.5	0.589	0.317	0.276	0.068	0.059
2	7.68	10.00	9.5	6.9	6.5	0.539	0.264	0.220	0.058	0.048
3	26.35	30.01	12.6	8.3	4.5	0.566	0.239	0.198	0.052	0.043
4	35.99	40.01	14.5	9.6	6.1	0.628	0.317	0.288	0.068	0.061
5	38.18	42.49	15.0	9.9	7.2	0.676	0.350	0.323	0.074	0.068
6	40.78	45.00	15.5	10.3	10.0	0.735	0.385	0.361	0.077	0.072
7	43.25	47.51	15.8	10.5	16.6	0.787	0.426	0.406	0.074	0.071
8	45.71	50.01	16.0	10.8	18.3	0.817	0.448	0.430	0.075	0.072
9	65.92	69.99	15.7	9.1	-1.9	0.574	0.225	0.224	0.052	0.051
10	88.58	90.00	14.8	7.5	5.1	0.393	0.093	0.093	0.019	0.019
11	95.09	95.01	13.4	6.0	2.8	0.374	0.089	0.089	0.018	0.018

TABLE XIV. - BLADE ELEMENT PERFORMANCE FOR ROTOR 3, 90 PERCENT DESIGN SPEED

(a) Reading 521

RP	RADII		ABS BETAM		REL BETAM		TOTAL TEMP		TOTAL PRESS	
	IN	OUT	IN	OUT	IN	OUT	IN	OUT	IN	OUT
1	9.729	9.578	0.	29.7	61.4	54.5	518.7	590.2	14.69	21.10
2	9.510	9.386	0.	29.5	61.2	53.1	518.7	588.9	14.69	21.23
3	8.598	8.620	0.	29.4	58.1	49.0	518.7	585.2	14.69	20.90
4	8.127	8.237	0.	35.6	56.6	51.5	518.7	580.3	14.69	18.86
5	8.020	8.142	0.	36.8	56.2	54.3	518.7	577.6	14.69	18.04
6	7.893	8.046	0.	37.6	55.7	54.3	518.7	578.3	14.69	17.82
7	7.772	7.950	0.	37.5	55.3	51.4	518.7	580.5	14.69	18.21
8	7.652	7.854	0.	35.3	54.9	47.2	518.7	582.3	14.69	19.08
9	6.665	7.089	0.	32.1	51.4	35.0	518.7	581.7	14.69	21.29
10	5.558	6.323	0.	36.0	49.7	22.1	518.7	587.2	14.69	22.04
11	5.240	6.131	0.	37.6	48.5	17.8	518.7	591.2	14.69	22.21

RP	ABS VEL		REL VEL		MERID VEL		TANG VEL		WHEEL SPEED	
	IN	OUT	IN	OUT	IN	OUT	IN	OUT	IN	OUT
1	668.5	704.1	1394.8	1052.0	668.5	611.5	0.	349.0	1224.1	1205.1
2	658.8	715.5	1366.6	1036.8	658.8	622.6	0.	352.7	1197.3	1181.7
3	673.2	726.9	1275.4	966.3	673.2	633.6	0.	356.4	1083.3	1086.1
4	675.2	646.9	1226.0	844.6	675.2	526.2	0.	376.5	1023.3	1037.1
5	675.9	598.1	1215.3	821.3	675.9	479.1	0.	358.2	1010.0	1025.3
6	677.2	592.2	1202.8	803.4	677.2	469.4	0.	361.2	994.0	1013.2
7	678.8	624.9	1191.8	795.5	678.8	496.0	0.	380.2	979.6	1002.1
8	677.9	678.9	1179.1	815.3	677.9	554.2	0.	392.2	964.8	990.2
9	670.4	795.0	1074.9	822.3	670.4	673.8	0.	422.3	840.2	893.7
10	593.2	869.9	917.9	760.0	593.2	704.1	0.	510.8	700.5	796.9
11	584.4	893.1	881.7	743.5	584.4	707.7	0.	544.7	660.2	772.5

RP	ABS MACH NO		REL MACH NO		MERID MACH NO		MERID VEL R	PEAK SS MACH NO	EFF
	IN	OUT	IN	OUT	IN	OUT			
1	0.622	0.613	1.297	0.916	0.622	0.532	0.915	1.432	0.790
2	0.612	0.625	1.269	0.905	0.612	0.543	0.945	1.452	0.818
3	0.626	0.638	1.186	0.847	0.626	0.556	0.941	1.492	0.827
4	0.628	0.565	1.141	0.738	0.628	0.460	0.779	1.476	0.623
5	0.629	0.521	1.131	0.716	0.629	0.418	0.709	1.475	0.531
6	0.630	0.516	1.119	0.700	0.630	0.409	0.695	1.468	0.493
7	0.632	0.545	1.109	0.693	0.632	0.432	0.731	1.464	0.531
8	0.631	0.594	1.097	0.713	0.631	0.485	0.818	1.459	0.632
9	0.623	0.705	1.000	0.729	0.623	0.598	1.005	1.423	0.921
10	0.547	0.775	0.847	0.677	0.547	0.627	1.187	1.223	0.929
11	0.538	0.795	0.812	0.662	0.538	0.630	1.211	1.142	0.896

RP	PERCENT SPAN		INCIDENCE		DEV	D-FACT	LOSS COEFF		LOSS PARAM	
	IN	OUT	MEAN	SS			TOT	PROF	TOT	PROF
1	3.19	4.99	-0.4	-2.6	7.6	0.337	0.133	0.080	0.028	0.017
2	7.68	10.00	0.6	-1.9	6.8	0.334	0.117	0.064	0.025	0.014
3	26.33	30.01	2.3	-1.6	4.6	0.335	0.116	0.068	0.025	0.015
4	35.99	40.01	3.3	-1.6	10.4	0.408	0.243	0.203	0.047	0.040
5	38.18	42.49	3.6	-1.5	14.3	0.416	0.291	0.253	0.053	0.046
6	40.78	45.00	3.7	-1.5	15.1	0.424	0.322	0.286	0.057	0.051
7	43.25	47.51	3.8	-1.6	13.3	0.430	0.313	0.278	0.059	0.052
8	45.71	50.01	3.9	-1.6	10.1	0.408	0.259	0.226	0.052	0.046
9	65.92	69.99	4.5	-2.0	7.3	0.338	0.066	0.048	0.014	0.010
10	88.58	90.00	8.4	-1.9	7.2	0.300	0.083	0.083	0.017	0.017
11	95.09	95.01	4.3	-3.1	6.6	0.292	0.136	0.136	0.026	0.026

TABLE XIV. - Continued. BLADE ELEMENT PERFORMANCE FOR ROTOR 3, 90 PERCENT DESIGN SPEED

(b) Reading 523

RP	RADII		ABS BETAM		REL BETAM		TOTAL TEMP		TOTAL PRESS	
	IN	OUT	IN	OUT	IN	OUT	IN	OUT	IN	OUT
1	9.729	9.378	0.	98.1	61.8	53.2	518.7	606.8	14.69	23.98
2	9.510	9.386	0.	96.8	61.6	52.3	518.7	604.8	14.69	23.43
3	8.598	8.620	0.	97.9	58.7	47.9	518.7	600.3	14.69	23.11
4	8.127	8.237	0.	49.2	57.2	47.6	518.7	597.0	14.69	21.64
5	8.020	8.142	0.	49.7	56.9	49.4	518.7	594.4	14.69	20.97
6	7.893	8.046	0.	49.8	56.4	49.8	518.7	592.9	14.69	20.62
7	7.772	7.950	0.	49.1	56.0	48.1	518.7	593.2	14.69	20.86
8	7.652	7.854	0.	41.2	55.6	45.3	518.7	591.8	14.69	21.33
9	6.665	7.089	0.	57.6	52.3	34.7	518.7	589.3	14.69	22.41
10	5.558	6.323	0.	59.3	50.3	22.3	518.7	590.3	14.69	22.60
11	5.240	6.131	0.	40.2	49.7	18.3	518.7	594.7	14.69	22.71

RP	ABS VEL		REL VEL		MERID VEL		TANG VEL		WHEEL SPEED	
	IN	OUT	IN	OUT	IN	OUT	IN	OUT	IN	OUT
1	656.5	721.9	1388.7	948.2	656.5	568.0	0.	445.5	1223.7	1204.7
2	647.3	723.4	1361.1	946.2	647.3	579.1	0.	433.5	1197.4	1181.7
3	658.3	739.2	1266.3	866.3	658.3	587.8	0.	448.1	1081.8	1084.6
4	659.4	698.9	1216.3	755.3	659.4	509.7	0.	478.4	1022.0	1035.8
5	659.3	667.4	1204.8	741.2	659.3	482.2	0.	461.3	1009.0	1024.3
6	658.8	653.3	1191.9	732.3	658.8	471.6	0.	452.4	993.4	1012.6
7	658.8	667.9	1179.0	730.8	658.8	488.0	0.	456.1	977.7	1000.1
8	658.1	693.3	1165.6	744.4	658.1	523.4	0.	458.1	862.1	887.3
9	649.3	770.7	1061.6	742.3	649.3	610.4	0.	470.5	839.8	893.2
10	577.1	836.2	907.9	699.9	577.1	646.8	0.	530.0	700.9	797.3
11	558.4	860.0	864.2	692.0	558.4	637.1	0.	554.7	659.6	771.7

RP	ABS MACH NO		REL MACH NO		MERID MACH NO		MERID VEL R	PEAK SS MACH NO	EFF
	IN	OUT	IN	OUT	IN	OUT			
1	0.610	0.620	1.289	0.813	0.610	0.488	0.863	1.440	0.836
2	0.600	0.623	1.263	0.813	0.600	0.499	0.893	1.461	0.839
3	0.611	0.640	1.176	0.739	0.611	0.399	0.893	1.302	0.877
4	0.612	0.605	1.139	0.653	0.612	0.441	0.773	1.488	0.774
5	0.612	0.577	1.119	0.641	0.612	0.417	0.732	1.489	0.733
6	0.612	0.565	1.107	0.633	0.612	0.408	0.716	1.484	0.711
7	0.612	0.578	1.095	0.632	0.612	0.422	0.741	1.479	0.732
8	0.611	0.604	1.082	0.647	0.611	0.455	0.793	1.474	0.797
9	0.602	0.677	0.983	0.632	0.602	0.536	0.940	1.431	0.941
10	0.531	0.739	0.836	0.619	0.531	0.572	1.121	1.229	0.943
11	0.513	0.760	0.794	0.611	0.513	0.381	1.177	1.132	0.903

RP	PERCENT SPAN		INCIDENCE		DEV	D-FACT	LOSS COEFF		LOSS PARAF	
	IN	OUT	MEAN	SS			TOT	PROF	TOT	PROF
1	3.18	4.99	0.1	-2.2	6.4	0.434	0.125	0.072	0.028	0.016
2	7.68	10.00	1.1	-1.3	3.9	0.419	0.108	0.053	0.024	0.012
3	26.33	30.01	3.1	-1.1	2.9	0.433	0.100	0.051	0.022	0.011
4	35.99	40.01	3.9	-1.0	6.5	0.393	0.103	0.144	0.039	0.030
5	38.18	42.49	4.2	-0.8	8.4	0.304	0.213	0.174	0.043	0.033
6	40.78	43.00	4.4	-0.8	10.8	0.303	0.231	0.184	0.043	0.038
7	43.23	47.31	4.3	-0.8	10.0	0.408	0.218	0.183	0.044	0.037
8	43.71	50.01	4.6	-0.8	8.2	0.479	0.168	0.133	0.033	0.028
9	63.82	60.00	3.4	-1.1	7.1	0.417	0.093	0.038	0.012	0.008
10	88.38	80.00	6.2	-1.1	7.9	0.334	0.068	0.067	0.014	0.014
11	83.88	83.01	3.3	-1.0	7.0	0.348	0.133	0.133	0.023	0.023

TABLE XIV. - Continued. BLADE ELEMENT PERFORMANCE FOR ROTOR 3, 90 PERCENT DESIGN SPEED

(c) Reading 525

RP	RADII		ABS BETAM		REL BETAM		TOTAL TEMP		TOTAL PRESS	
	IN	OUT	IN	OUT	IN	OUT	IN	OUT	IN	OUT
1	9.729	9.578	0.	42.6	62.6	52.7	518.7	618.3	14.69	24.60
2	9.510	9.386	0.	41.1	62.4	51.9	518.7	613.6	14.69	24.50
3	8.598	8.620	0.	41.4	59.7	46.7	518.7	607.7	14.69	24.12
4	8.127	8.237	0.	45.7	58.3	46.1	518.7	604.8	14.69	23.10
5	8.020	8.142	0.	47.3	58.0	46.9	518.7	604.9	14.69	22.60
6	7.893	8.046	0.	48.6	57.6	47.0	518.7	603.1	14.69	22.22
7	7.772	7.950	0.	47.8	57.2	45.9	518.7	600.6	14.69	22.22
8	7.652	7.854	0.	46.0	56.9	44.3	518.7	601.1	14.69	22.40
9	6.663	7.089	0.	41.5	53.7	34.3	518.7	594.9	14.69	22.92
10	5.558	6.323	0.	41.7	51.8	22.8	518.7	591.7	14.69	22.81
11	5.240	6.131	0.	42.4	49.9	18.4	518.7	593.2	14.69	23.03

RP	ABS VEL		REL VEL		MERID VEL		TANG VEL		WHEEL SPEED	
	IN	OUT	IN	OUT	IN	OUT	IN	OUT	IN	OUT
1	634.4	733.4	1379.4	891.6	634.4	540.0	0.	496.3	1224.9	1205.9
2	624.2	728.4	1348.2	889.8	624.2	548.7	0.	479.0	1195.0	1179.4
3	633.1	744.8	1253.3	814.1	633.1	558.8	0.	492.4	1081.7	1084.5
4	631.7	719.9	1202.6	725.1	631.7	503.2	0.	515.1	1023.3	1037.2
5	631.4	701.7	1190.8	696.9	631.4	475.8	0.	515.8	1009.6	1025.0
6	629.2	693.9	1175.6	673.0	629.2	459.2	0.	520.3	993.1	1012.3
7	628.7	696.6	1161.3	672.3	628.7	468.0	0.	516.2	976.4	998.8
8	628.8	707.6	1150.1	687.0	628.8	491.9	0.	508.7	963.0	988.4
9	616.3	760.6	1040.8	689.0	616.3	569.5	0.	504.2	838.7	892.1
10	549.9	812.6	890.1	658.2	549.9	606.6	0.	540.7	699.9	796.2
11	554.8	839.2	861.9	633.1	554.8	619.8	0.	565.8	659.6	771.7

RP	ABS MACH NO		REL MACH NO		MERID MACH NO		MERID VEL R	PEAK SS MACH NO	EFF
	IN	OUT	IN	OUT	IN	OUT			
1	0.588	0.625	1.278	0.760	0.588	0.460	0.851	1.458	0.826
2	0.578	0.623	1.247	0.761	0.578	0.469	0.879	1.475	0.859
3	0.586	0.641	1.161	0.701	0.586	0.481	0.883	1.523	0.886
4	0.585	0.620	1.114	0.624	0.585	0.433	0.797	1.515	0.831
5	0.585	0.603	1.103	0.599	0.585	0.409	0.794	1.516	0.787
6	0.582	0.597	1.088	0.579	0.582	0.395	0.730	1.512	0.771
7	0.582	0.600	1.075	0.579	0.582	0.403	0.744	1.508	0.794
8	0.582	0.610	1.065	0.593	0.582	0.424	0.782	1.505	0.806
9	0.570	0.664	0.962	0.601	0.570	0.497	0.924	1.444	0.922
10	0.505	0.716	0.817	0.580	0.505	0.534	1.103	1.239	0.951
11	0.510	0.740	0.792	0.576	0.510	0.547	1.117	1.153	0.954

RP	PERCENT SPAN		INCIDENCE		DEV	D-FACT	LOSS COEFF		LOSS PARAM	
	IN	OUT	MEAN	SS			TOT	PROF	TOT	PROF
1	3.19	4.99	0.9	-1.4	5.9	0.485	0.147	0.093	0.033	0.021
2	7.68	10.00	1.9	-0.7	5.6	0.467	0.119	0.066	0.027	0.015
3	28.35	30.01	4.0	-0.1	2.2	0.480	0.101	0.051	0.023	0.011
4	35.99	40.01	5.0	0.1	5.0	0.532	0.134	0.111	0.033	0.024
5	38.18	42.49	5.3	0.3	6.9	0.550	0.193	0.153	0.041	0.032
6	40.78	45.00	5.6	0.4	7.8	0.564	0.209	0.170	0.044	0.035
7	43.25	47.51	5.7	0.4	7.8	0.556	0.187	0.150	0.039	0.031
8	45.71	50.01	5.8	0.4	7.2	0.536	0.180	0.145	0.038	0.031
9	65.92	69.99	6.8	0.3	6.7	0.466	0.080	0.064	0.017	0.013
10	88.58	90.00	7.5	0.2	7.9	0.401	0.063	0.063	0.013	0.013
11	95.08	95.01	5.7	-1.7	7.1	0.386	0.064	0.064	0.012	0.012

TABLE XIV. - Continued. BLADE ELEMENT PERFORMANCE FOR ROTOR 3, 90 PERCENT DESIGN SPEED

(d) Reading 542

RP	RADII		ABS BETAM		REL BETAM		TOTAL TEMP		TOTAL PRESS	
	IN	OUT	IN	OUT	IN	OUT	IN	OUT	IN	OUT
1	9.729	9.578	0.	47.4	64.8	52.3	518.7	633.9	14.69	25.45
2	9.510	9.386	0.	45.9	64.6	51.6	518.7	624.8	14.69	25.45
3	8.598	8.620	0.	44.9	62.4	46.9	518.7	614.6	14.69	24.78
4	8.127	8.237	0.	48.5	61.0	45.6	518.7	612.8	14.69	24.02
5	8.020	8.142	0.	50.4	60.7	46.3	518.7	613.1	14.69	23.54
6	7.893	8.046	0.	52.9	60.3	46.0	518.7	613.1	14.69	23.16
7	7.772	7.950	0.	52.6	60.1	44.8	518.7	611.1	14.69	23.11
8	7.652	7.854	0.	51.1	59.6	42.5	518.7	610.1	14.69	23.26
9	6.663	7.089	0.	45.6	56.2	34.2	518.7	598.2	14.69	23.30
10	5.958	6.323	0.	44.6	53.1	22.8	518.7	595.2	14.69	23.05
11	5.240	6.131	0.	46.4	52.7	15.4	518.7	599.3	14.69	23.64

RP	ABS VEL		REL VEL		MERID VEL		TANG VEL		WHEEL SPEED	
	IN	OUT	IN	OUT	IN	OUT	IN	OUT	IN	OUT
1	575.9	747.9	1353.9	827.7	575.9	505.8	0.	551.1	1225.3	1206.2
2	568.3	741.5	1326.5	830.4	568.3	516.3	0.	532.6	1198.6	1183.0
3	566.5	742.0	1222.8	769.5	566.5	525.4	0.	524.2	1083.7	1086.5
4	567.9	728.0	1171.8	690.2	567.9	482.5	0.	545.4	1025.0	1038.9
5	567.5	713.7	1158.6	658.2	567.5	455.1	0.	549.8	1010.0	1025.4
6	568.6	712.8	1146.1	619.6	568.6	430.1	0.	568.4	995.1	1014.4
7	564.3	717.8	1131.0	614.2	564.3	436.1	0.	570.2	980.2	1002.6
8	564.6	730.7	1117.1	622.2	564.6	458.6	0.	568.8	963.9	989.4
9	563.3	752.2	1012.4	635.8	563.3	526.1	0.	537.8	841.3	894.8
10	526.5	796.1	876.6	614.5	526.5	566.5	0.	559.4	700.9	797.4
11	504.1	845.6	831.1	604.6	504.1	582.9	0.	612.6	660.8	773.1

RP	ABS MACH NO		REL MACH NO		MERID MACH NO		MERID VEL R	PEAK SS MACH NO	EFF
	IN	OUT	IN	OUT	IN	OUT			
1	0.530	0.630	1.246	0.697	0.530	0.426	0.878	1.504	0.765
2	0.523	0.629	1.220	0.704	0.523	0.438	0.908	1.526	0.831
3	0.521	0.635	1.125	0.658	0.521	0.449	0.927	1.588	0.871
4	0.522	0.623	1.078	0.590	0.522	0.413	0.850	1.584	0.831
5	0.522	0.609	1.066	0.562	0.522	0.389	0.802	1.584	0.792
6	0.523	0.609	1.054	0.529	0.523	0.367	0.756	1.581	0.762
7	0.519	0.614	1.040	0.526	0.519	0.373	0.773	1.586	0.775
8	0.519	0.627	1.027	0.534	0.519	0.393	0.812	1.583	0.796
9	0.518	0.654	0.931	0.553	0.518	0.457	0.934	1.476	0.919
10	0.483	0.697	0.803	0.538	0.483	0.496	1.076	1.251	0.931
11	0.461	0.743	0.760	0.531	0.461	0.512	1.156	1.177	0.936

RP	PERCENT SPAN		INCIDENCE		DEV	D-FACT	LOSS COEFF		LOSS PARAM	
	IN	OUT	MEAN	SS			TOT	PROF	TOT	PROF
1	3.19	4.99	3.1	0.8	5.5	0.537	0.227	0.168	0.051	0.038
2	7.68	10.00	4.1	1.5	5.2	0.518	0.159	0.100	0.036	0.022
3	26.35	30.01	6.8	2.6	2.5	0.512	0.127	0.069	0.029	0.015
4	35.99	40.01	7.8	2.9	4.6	0.558	0.172	0.121	0.038	0.027
5	38.18	42.49	8.0	3.0	6.2	0.580	0.214	0.165	0.046	0.033
6	40.78	45.00	8.2	3.0	6.9	0.612	0.247	0.200	0.052	0.042
7	43.25	47.51	8.5	3.2	6.7	0.610	0.235	0.188	0.050	0.040
8	45.71	50.01	8.6	3.2	5.4	0.596	0.216	0.172	0.047	0.038
9	65.92	69.99	9.3	2.8	6.6	0.512	0.091	0.074	0.019	0.016
10	88.58	90.00	8.7	1.4	7.8	0.446	0.095	0.095	0.019	0.019
11	95.09	95.01	8.4	1.0	4.2	0.434	0.101	0.101	0.020	0.020

TABLE XIV. - Concluded. BLADE ELEMENT PERFORMANCE FOR ROTOR 3, 90 PERCENT DESIGN SPEED

(e) Reading 544

RP	RADII		ABS BETAM		REL BETAM		TOTAL TEMP		TOTAL PRESS	
	IN	OUT	IN	OUT	IN	OUT	IN	OUT	IN	OUT
1	9.729	9.578	0.	49.0	66.8	52.3	518.7	634.2	14.69	24.95
2	9.510	9.386	0.	46.4	66.7	51.3	518.7	625.6	14.69	24.94
3	8.598	8.620	0.	47.2	64.3	47.8	518.7	614.9	14.69	24.05
4	8.127	8.237	0.	52.1	63.4	46.6	518.7	614.8	14.69	23.28
5	8.020	8.142	0.	54.5	63.2	47.3	518.7	614.6	14.69	22.91
6	7.893	8.046	0.	57.9	62.7	47.5	518.7	615.2	14.69	22.58
7	7.772	7.950	0.	59.9	62.5	47.5	518.7	613.4	14.69	22.38
8	7.652	7.854	0.	59.7	62.2	45.2	518.7	613.4	14.69	22.46
9	6.665	7.089	0.	47.0	58.6	31.7	518.7	601.6	14.69	23.14
10	5.558	6.323	0.	44.4	55.2	21.5	518.7	595.2	14.69	23.10
11	5.240	6.131	0.	45.8	54.3	15.1	518.7	599.6	14.69	23.66

RP	ABS VEL		REL VEL		MERID VEL		TANG VEL		WHEEL SPEED	
	IN	OUT	IN	OUT	IN	OUT	IN	OUT	IN	OUT
1	525.2	751.5	1332.1	805.6	525.2	492.6	0.	567.8	1224.2	1205.2
2	515.1	745.7	1303.1	822.5	515.1	514.7	0.	539.9	1197.0	1181.4
3	521.3	733.9	1203.9	742.4	521.3	499.0	0.	538.3	1085.2	1088.0
4	513.6	721.1	1145.3	644.9	513.6	443.1	0.	569.0	1023.7	1037.6
5	510.2	709.9	1130.5	607.0	510.2	411.9	0.	578.2	1008.8	1024.2
6	512.3	709.2	1117.3	557.6	512.3	376.5	0.	601.0	992.9	1012.2
7	510.8	709.2	1104.9	526.4	510.8	355.3	0.	613.7	979.7	1002.2
8	508.5	720.8	1089.3	516.2	508.5	363.5	0.	622.3	963.3	988.7
9	513.3	774.7	984.1	620.8	513.3	528.2	0.	566.8	839.6	893.0
10	486.8	813.0	853.8	623.8	486.8	580.4	0.	569.3	701.4	798.0
11	474.8	854.8	813.7	617.6	474.8	596.3	0.	612.5	660.8	773.1

RP	ABS MACH NO		REL MACH NO		MERID MACH NO		MERID VEL R	PEAK SS	EFF
	IN	OUT	IN	OUT	IN	OUT			
1	0.481	0.633	1.221	0.678	0.481	0.415	0.938	1.547	0.733
2	0.472	0.632	1.193	0.697	0.472	0.436	0.999	1.573	0.791
3	0.477	0.627	1.103	0.634	0.477	0.426	0.957	1.639	0.815
4	0.470	0.615	1.048	0.550	0.470	0.378	0.863	1.648	0.758
5	0.467	0.605	1.035	0.518	0.467	0.351	0.807	1.634	0.732
6	0.469	0.604	1.023	0.473	0.469	0.321	0.735	1.651	0.702
7	0.468	0.605	1.011	0.449	0.468	0.303	0.696	1.637	0.700
8	0.465	0.616	0.997	0.441	0.465	0.311	0.715	1.656	0.705
9	0.470	0.673	0.901	0.539	0.470	0.459	1.029	1.500	0.866
10	0.445	0.714	0.780	0.548	0.445	0.509	1.192	1.272	0.933
11	0.433	0.751	0.742	0.543	0.433	0.524	1.256	1.191	0.933

RP	PERCENT SPAN		INCIDENCE		DEV	D-FACT	LOSS COEFF		LOSS PARAM	
	IN	OUT	MEAN	SS			TOT	PROF	TOT	PROF
1	3.19	4.99	5.0	2.8	5.5	0.550	0.262	0.198	0.039	0.045
2	7.68	10.00	6.1	3.6	4.9	0.517	0.201	0.136	0.043	0.031
3	26.33	30.01	8.7	4.6	3.3	0.531	0.184	0.119	0.041	0.026
4	35.99	40.01	10.1	5.2	5.6	0.594	0.253	0.195	0.033	0.042
5	38.18	42.49	10.5	5.5	7.2	0.622	0.286	0.227	0.060	0.048
6	40.78	45.00	10.6	5.5	8.4	0.667	0.324	0.267	0.067	0.055
7	43.23	47.31	10.9	5.6	9.5	0.693	0.326	0.270	0.066	0.055
8	45.71	50.01	11.2	5.7	8.2	0.698	0.328	0.274	0.069	0.057
9	65.92	69.99	11.7	5.1	4.1	0.521	0.161	0.143	0.033	0.031
10	88.58	90.00	10.9	3.6	6.6	0.423	0.094	0.094	0.019	0.019
11	95.09	95.01	10.1	2.7	3.9	0.406	0.108	0.108	0.021	0.021

TABLE XV. - BLADE ELEMENT PERFORMANCE FOR ROTOR 3, 100 PERCENT DESIGN SPEED

(a) Reading 528

RP	RADII		ABS BETAM		REL BETAM		TOTAL TEMP		TOTAL PRESS	
	IN	OUT	IN	OUT	IN	OUT	IN	OUT	IN	OUT
1	9.729	9.578	0.	41.6	62.0	55.7	518.7	630.1	14.69	24.28
2	9.510	9.386	0.	39.0	61.9	54.1	518.7	626.5	14.69	24.65
3	8.598	8.620	0.	38.5	58.7	47.8	518.7	619.3	14.69	25.05
4	8.127	8.237	0.	45.6	57.2	49.7	518.7	612.7	14.69	22.68
5	8.020	8.142	0.	47.0	56.8	53.4	518.7	609.2	14.69	21.46
6	7.893	8.046	0.	47.8	56.4	53.7	518.7	608.5	14.69	21.19
7	7.772	7.950	0.	47.4	55.9	51.6	518.7	610.6	14.69	21.38
8	7.652	7.854	0.	44.8	55.5	47.9	518.7	610.7	14.69	22.08
9	6.665	7.089	0.	39.4	52.0	34.1	518.7	606.2	14.69	24.34
10	5.558	6.323	0.	40.3	50.0	23.1	518.7	605.0	14.69	24.53
11	5.240	6.131	0.	41.6	49.7	18.4	518.7	611.9	14.69	24.68

RP	ABS VEL		REL VEL		MERID VEL		TANG VEL		WHEEL SPEED	
	IN	OUT	IN	OUT	IN	OUT	IN	OUT	IN	OUT
1	721.0	757.5	1533.8	1005.2	721.0	566.8	0.	502.6	1353.8	1332.8
2	707.1	767.8	1501.2	1017.3	707.1	596.8	0.	483.1	1324.3	1307.0
3	726.5	807.4	1400.1	941.1	726.5	631.9	0.	502.6	1196.8	1199.9
4	729.3	743.9	1345.6	805.4	729.3	520.6	0.	531.6	1130.8	1146.1
5	729.0	686.2	1332.9	785.5	729.0	468.0	0.	501.9	1115.9	1132.9
6	728.7	676.0	1317.4	766.5	728.7	453.9	0.	501.0	1097.5	1118.7
7	732.8	695.2	1305.9	757.1	732.8	470.2	0.	512.2	1080.9	1105.6
8	731.9	733.5	1291.7	775.5	731.9	520.1	0.	517.3	1064.3	1092.4
9	725.6	851.8	1177.7	795.0	725.6	658.0	0.	540.5	927.7	986.7
10	648.8	905.7	1010.1	751.0	648.8	690.8	0.	586.1	774.2	880.8
11	618.6	934.6	956.6	736.3	618.6	698.5	0.	620.9	729.7	853.7

RP	ABS MACH NO		REL MACH NO		MERID MACH NO		MERID VEL R	PEAK SS MACH NO	EFF
	IN	OUT	IN	OUT	IN	OUT			
1	0.675	0.640	1.435	0.850	0.675	0.479	0.786	1.586	0.718
2	0.660	0.652	1.402	0.864	0.660	0.507	0.844	1.602	0.767
3	0.680	0.693	1.311	0.808	0.680	0.542	0.870	1.622	0.849
4	0.683	0.638	1.260	0.690	0.683	0.446	0.714	1.596	0.728
5	0.683	0.586	1.248	0.671	0.683	0.400	0.642	1.582	0.655
6	0.683	0.577	1.234	0.655	0.683	0.388	0.623	1.582	0.637
7	0.687	0.594	1.224	0.647	0.687	0.402	0.642	1.572	0.638
8	0.686	0.629	1.210	0.665	0.686	0.446	0.711	1.565	0.696
9	0.679	0.743	1.103	0.684	0.679	0.575	0.907	1.490	0.920
10	0.602	0.798	0.937	0.661	0.602	0.608	1.065	1.363	0.948
11	0.572	0.821	0.885	0.647	0.572	0.614	1.129	1.281	0.889

RP	PERCENT SPAN		INCIDENCE		DEV	D-FACT	LOSS COEFF		LOSS PARAM	
	IN	OUT	MEAN	SS			TOT	PROF	TOT	PROF
1	3.19	4.99	0.2	-2.0	8.9	0.464	0.228	0.123	0.047	0.026
2	7.68	10.00	1.4	-1.2	7.8	0.438	0.191	0.087	0.040	0.018
3	26.35	30.01	3.1	-1.0	3.4	0.446	0.130	0.037	0.029	0.008
4	35.99	40.01	3.9	-1.0	8.7	0.526	0.227	0.148	0.046	0.030
5	38.18	42.49	4.2	-0.9	13.4	0.528	0.279	0.203	0.051	0.037
6	40.78	45.00	4.3	-0.8	14.5	0.535	0.296	0.224	0.053	0.040
7	43.25	47.51	4.3	-1.0	13.5	0.540	0.304	0.235	0.057	0.044
8	45.71	50.01	4.5	-1.0	10.8	0.520	0.263	0.197	0.052	0.039
9	65.92	69.99	5.1	-1.4	6.5	0.446	0.079	0.042	0.017	0.009
10	88.58	90.00	5.7	-1.6	8.2	0.390	0.065	0.057	0.013	0.011
11	95.09	95.01	5.5	-1.9	7.2	0.373	0.161	0.159	0.031	0.031

TABLE XV. - Continued. BLADE ELEMENT PERFORMANCE FOR ROTOR 3, 100 PERCENT DESIGN SPEED

(b) Reading 530

RP	RADII		ABS BETAM		REL BETAM		TOTAL TEMP		TOTAL PRESS	
	IN	OUT	IN	OUT	IN	OUT	IN	OUT	IN	OUT
1	9.729	9.578	0.	45.7	62.4	55.3	518.7	659.8	14.69	25.96
2	9.510	9.586	0.	45.7	62.2	55.5	518.7	656.5	14.69	26.22
3	8.598	8.620	0.	42.7	59.1	46.9	518.7	631.4	14.69	26.46
4	8.127	8.257	0.	48.0	57.7	47.4	518.7	624.3	14.69	24.71
5	8.020	8.142	0.	49.4	57.4	50.1	518.7	621.7	14.69	25.55
6	7.893	8.046	0.	50.5	56.9	50.2	518.7	621.5	14.69	25.21
7	7.772	7.950	0.	49.8	56.5	48.2	518.7	619.7	14.69	25.42
8	7.652	7.854	0.	48.3	56.2	45.3	518.7	617.9	14.69	25.88
9	6.665	7.089	0.	42.4	52.7	33.3	518.7	612.6	14.69	25.22
10	5.558	6.523	0.	42.3	50.8	25.1	518.7	607.5	14.69	24.82
11	5.240	6.131	0.	45.8	50.5	17.5	518.7	614.7	14.69	25.14

RP	ABS VEL		REL VEL		MERID VEL		TANG VEL		WHEEL SPEED	
	IN	OUT	IN	OUT	IN	OUT	IN	OUT	IN	OUT
1	706.4	772.7	1526.9	947.8	706.4	539.4	0.	553.3	1353.6	1332.6
2	698.3	783.1	1496.6	952.7	698.3	566.6	0.	540.5	1323.7	1306.5
3	716.0	820.2	1395.7	882.7	716.0	602.8	0.	556.3	1198.1	1201.1
4	716.0	779.7	1339.6	770.8	716.0	521.5	0.	579.9	1132.1	1147.5
5	713.3	736.9	1323.8	746.4	713.3	479.2	0.	559.9	1115.2	1132.1
6	713.8	728.9	1308.5	723.3	713.8	463.5	0.	562.6	1096.7	1118.0
7	713.6	743.1	1294.4	719.7	713.6	479.4	0.	567.9	1080.0	1104.7
8	713.6	770.3	1281.2	728.0	713.6	512.5	0.	575.1	1064.1	1092.2
9	705.9	851.2	1166.1	751.6	705.9	628.1	0.	574.5	928.2	987.2
10	631.3	890.0	998.7	715.8	631.3	658.2	0.	599.1	773.9	880.4
11	600.4	927.2	944.3	701.4	600.4	669.0	0.	642.0	728.8	852.8

RP	ABS MACH NO		REL MACH NO		MERID MACH NO		MERID VEL R	PEAK SS MACH NO	EFF
	IN	OUT	IN	OUT	IN	OUT			
1	0.660	0.649	1.426	0.796	0.660	0.453	0.764	1.593	0.756
2	0.652	0.660	1.396	0.803	0.652	0.478	0.811	1.607	0.792
3	0.670	0.698	1.308	0.781	0.670	0.513	0.842	1.630	0.843
4	0.670	0.664	1.253	0.657	0.670	0.444	0.728	1.606	0.786
5	0.667	0.626	1.237	0.634	0.667	0.407	0.672	1.601	0.726
6	0.667	0.619	1.223	0.614	0.667	0.394	0.649	1.591	0.704
7	0.667	0.633	1.210	0.613	0.667	0.408	0.672	1.584	0.732
8	0.667	0.659	1.198	0.623	0.667	0.439	0.718	1.577	0.778
9	0.659	0.739	1.089	0.652	0.659	0.545	0.890	1.507	0.921
10	0.585	0.780	0.925	0.627	0.585	0.577	1.043	1.369	0.944
11	0.554	0.812	0.871	0.614	0.554	0.586	1.114	1.286	0.896

RP	PERCENT SPAN		INCIDENCE		DEV	D-FACT	LOSS COEFF		LOSS PARAM	
	IN	OUT	MEAN	SS			TOT	PROF	TOT	PROF
1	3.19	4.99	0.7	-1.5	8.5	0.511	0.213	0.108	0.045	0.023
2	7.68	10.00	1.6	-0.9	7.2	0.493	0.184	0.081	0.039	0.017
3	26.33	30.01	3.5	-0.6	2.5	0.499	0.148	0.054	0.033	0.012
4	35.99	40.01	4.4	-0.5	6.4	0.561	0.200	0.119	0.042	0.025
5	38.18	42.49	4.7	-0.3	10.0	0.568	0.251	0.174	0.050	0.035
6	40.78	45.00	4.9	-0.3	11.0	0.580	0.274	0.202	0.054	0.039
7	43.25	47.51	5.0	-0.3	10.2	0.577	0.250	0.181	0.050	0.036
8	45.71	50.01	5.2	-0.3	8.2	0.567	0.209	0.143	0.044	0.030
9	65.92	69.99	5.9	-0.7	5.7	0.485	0.084	0.045	0.018	0.010
10	88.58	90.00	6.5	-0.9	8.2	0.422	0.073	0.066	0.015	0.015
11	95.09	95.01	6.3	-1.1	6.2	0.406	0.158	0.157	0.031	0.030

TABLE XV. - Continued. BLADE ELEMENT PERFORMANCE FOR ROTOR 3, 100 PERCENT DESIGN SPEED

(c) Reading 531

RP	RADII		ABS BETAM		REL BETAM		TOTAL TEMP		TOTAL PRESS	
	IN	OUT	IN	OUT	IN	OUT	IN	OUT	IN	OUT
1	9.729	9.578	0.	47.4	62.6	55.1	518.7	645.7	14.69	26.80
2	9.510	9.386	0.	45.4	62.4	53.5	518.7	641.5	14.69	26.96
3	8.598	8.620	0.	44.5	59.5	46.7	518.7	636.5	14.69	26.98
4	8.127	8.237	0.	49.0	58.1	47.2	518.7	628.5	14.69	25.21
5	8.020	8.142	0.	50.1	57.8	48.8	518.7	626.2	14.69	24.53
6	7.893	8.046	0.	51.8	57.4	49.2	518.7	624.2	14.69	23.96
7	7.772	7.950	0.	51.4	57.0	47.6	518.7	623.5	14.69	24.08
8	7.652	7.854	0.	49.4	56.6	45.2	518.7	621.6	14.69	24.58
9	6.665	7.089	0.	45.6	53.2	33.4	518.7	615.0	14.69	25.44
10	5.558	6.323	0.	43.2	51.3	23.1	518.7	609.0	14.69	24.97
11	5.240	6.131	0.	44.9	50.8	16.8	518.7	616.1	14.69	25.40

RP	ABS VEL		REL VEL		MERID VEL		TANG VEL		WHEEL SPEED	
	IN	OUT	IN	OUT	IN	OUT	IN	OUT	IN	OUT
1	702.1	781.8	1526.1	924.5	702.1	528.9	0.	576.0	1355.0	1334.0
2	692.7	786.7	1494.9	929.4	692.7	552.5	0.	560.1	1324.7	1307.4
3	705.4	822.4	1388.9	856.1	705.4	586.8	0.	576.2	1196.4	1199.5
4	703.5	784.6	1333.0	737.7	703.5	515.2	0.	591.9	1132.2	1147.6
5	705.0	757.3	1322.0	736.6	705.0	485.4	0.	581.3	1118.3	1135.4
6	703.4	745.0	1304.6	705.6	703.4	460.7	0.	585.6	1098.7	1120.0
7	703.7	755.8	1291.5	699.9	703.7	471.7	0.	590.7	1082.9	1107.7
8	702.9	774.6	1277.8	715.3	702.9	504.3	0.	587.9	1067.0	1095.2
9	693.9	845.4	1157.9	733.5	693.9	612.6	0.	582.5	926.9	985.9
10	619.6	884.5	991.5	700.5	619.6	644.4	0.	605.9	774.0	880.6
11	595.5	926.9	941.5	685.5	595.5	656.1	0.	654.7	729.3	853.3

RP	ABS MACH NO		REL MACH NO		MERID MACH NO		MERID VEL R	PEAK SS MACH NO	EFF
	IN	OUT	IN	OUT	IN	OUT			
1	0.655	0.654	1.425	0.773	0.655	0.442	0.753	1.597	0.765
2	0.646	0.661	1.394	0.781	0.646	0.464	0.798	1.611	0.801
3	0.659	0.697	1.297	0.725	0.659	0.497	0.832	1.634	0.835
4	0.657	0.666	1.245	0.643	0.657	0.437	0.732	1.614	0.788
5	0.658	0.642	1.235	0.625	0.658	0.412	0.688	1.611	0.761
6	0.657	0.632	1.218	0.599	0.657	0.391	0.655	1.601	0.737
7	0.657	0.643	1.206	0.595	0.657	0.401	0.670	1.595	0.750
8	0.656	0.661	1.193	0.610	0.656	0.430	0.717	1.589	0.798
9	0.647	0.732	1.080	0.635	0.647	0.530	0.883	1.516	0.915
10	0.573	0.774	0.917	0.613	0.573	0.564	1.040	1.374	0.939
11	0.549	0.810	0.869	0.599	0.549	0.574	1.102	1.289	0.901

RP	PERCENT SPAN		INCIDENCE		DEV	D-FACT	LOSS COEFF		LOSS PARAM	
	IN	OUT	MEAN	SS			TOT	PROF	TOT	PROF
1	3.19	4.99	0.9	-1.4	8.3	0.532	0.214	0.108	0.045	0.023
2	7.68	10.00	1.8	-0.7	7.2	0.513	0.182	0.078	0.039	0.017
3	26.35	30.01	3.9	-0.3	2.3	0.521	0.162	0.069	0.037	0.016
4	35.99	40.01	4.9	0.0	6.1	0.572	0.206	0.125	0.044	0.027
5	38.18	42.49	5.1	0.1	8.7	0.580	0.229	0.151	0.047	0.031
6	40.78	45.00	5.3	0.1	10.1	0.597	0.252	0.178	0.050	0.035
7	43.25	47.51	5.5	0.1	9.5	0.597	0.242	0.171	0.049	0.033
8	45.71	50.01	5.6	0.2	8.1	0.579	0.198	0.150	0.041	0.027
9	63.82	69.99	6.3	-0.2	5.8	0.499	0.094	0.055	0.020	0.012
10	88.58	90.00	7.0	-0.3	8.1	0.434	0.081	0.074	0.016	0.015
11	95.09	95.01	6.6	-0.9	5.6	0.424	0.153	0.152	0.030	0.030

TABLE XV. - Continued. BLADE ELEMENT PERFORMANCE FOR ROTOR 3, 100 PERCENT DESIGN SPEED

(d) Reading 532

RP	RADII		ABS BETAM		REL BETAM		TOTAL TEMP		TOTAL PRESS	
	IN	OUT	IN	OUT	IN	OUT	IN	OUT	IN	OUT
1	9.729	9.578	0.	49.6	63.3	53.2	518.7	654.4	14.69	27.95
2	9.510	9.386	0.	47.7	63.0	51.9	518.7	648.7	14.69	27.96
3	8.598	8.620	0.	46.5	60.2	46.0	518.7	638.8	14.69	27.55
4	8.127	8.237	0.	50.3	58.9	45.5	518.7	634.6	14.69	26.18
5	8.020	8.142	0.	51.9	58.6	46.7	518.7	633.5	14.69	25.50
6	7.893	8.046	0.	53.9	58.4	47.0	518.7	631.8	14.69	24.97
7	7.772	7.950	0.	53.5	57.9	45.9	518.7	629.5	14.69	24.92
8	7.652	7.854	0.	51.5	57.6	43.4	518.7	627.1	14.69	25.31
9	6.665	7.089	0.	45.9	54.2	32.7	518.7	616.7	14.69	25.72
10	5.558	6.323	0.	45.0	52.3	22.7	518.7	609.8	14.69	25.14
11	5.240	6.131	0.	46.9	51.7	15.9	518.7	616.1	14.69	25.61

RP	ABS VEL		REL VEL		MERID VEL		TANG VEL		WHEEL SPEED	
	IN	OUT	IN	OUT	IN	OUT	IN	OUT	IN	OUT
1	680.1	817.8	1514.7	885.2	680.1	529.9	0.	623.3	1353.4	1332.4
2	673.6	816.5	1483.8	890.0	673.6	549.0	0.	604.3	1322.1	1304.8
3	684.7	833.0	1377.0	824.8	684.7	573.1	0.	604.5	1194.7	1197.7
4	680.8	806.8	1319.6	735.4	680.8	515.3	0.	621.0	1130.4	1145.7
5	680.0	785.9	1306.9	707.3	680.0	485.1	0.	618.3	1116.1	1133.1
6	675.9	777.7	1289.3	671.1	675.9	457.9	0.	628.6	1098.0	1119.2
7	678.4	780.2	1277.0	666.6	678.4	463.6	0.	627.6	1081.8	1106.6
8	676.4	797.4	1262.4	683.4	676.4	496.2	0.	624.2	1065.9	1094.1
9	669.2	846.1	1142.9	699.9	669.2	589.0	0.	607.4	926.5	985.4
10	597.8	878.1	977.8	672.6	597.8	620.7	0.	621.1	773.7	880.2
11	575.6	922.5	929.0	656.0	575.6	630.9	0.	673.1	729.1	853.1

RP	ABS MACH NO		REL MACH NO		MERID MACH NO		MERID VEL R	PEAK SS MACH NO	EFF
	IN	OUT	IN	OUT	IN	OUT			
1	0.633	0.682	1.410	0.738	0.633	0.442	0.779	1.607	0.771
2	0.627	0.684	1.380	0.746	0.627	0.460	0.815	1.618	0.805
3	0.638	0.705	1.283	0.698	0.638	0.485	0.837	1.645	0.850
4	0.634	0.683	1.229	0.623	0.634	0.436	0.757	1.627	0.803
5	0.633	0.665	1.217	0.598	0.633	0.410	0.713	1.626	0.770
6	0.629	0.658	1.200	0.568	0.629	0.387	0.678	1.620	0.750
7	0.631	0.662	1.189	0.565	0.631	0.393	0.683	1.612	0.762
8	0.629	0.679	1.175	0.582	0.629	0.422	0.734	1.607	0.804
9	0.622	0.731	1.063	0.605	0.622	0.509	0.880	1.540	0.918
10	0.552	0.767	0.902	0.587	0.552	0.542	1.038	1.382	0.945
11	0.530	0.806	0.855	0.573	0.530	0.551	1.096	1.297	0.916

RP	PERCENT SPAN		INCIDENCE		DEV	D-FACT	LOSS COEFF		LOSS PARAM	
	IN	OUT	MEAN	SS			TOT	PROF	TOT	PROF
1	3.19	4.99	1.6	-0.7	6.4	0.565	0.221	0.116	0.049	0.025
2	7.68	10.00	2.5	-0.1	5.6	0.546	0.188	0.085	0.042	0.019
3	26.35	30.01	4.6	0.4	1.6	0.546	0.152	0.058	0.035	0.013
4	35.99	40.01	5.7	0.8	4.5	0.591	0.203	0.122	0.045	0.027
5	38.18	42.49	6.0	1.0	6.6	0.606	0.236	0.157	0.050	0.033
6	40.78	45.00	6.3	1.1	7.8	0.630	0.258	0.183	0.054	0.038
7	43.25	47.91	6.4	1.1	7.9	0.627	0.245	0.173	0.051	0.036
8	45.71	50.01	6.6	1.1	6.4	0.607	0.204	0.135	0.044	0.029
9	65.92	69.99	7.3	0.8	5.1	0.528	0.093	0.052	0.020	0.011
10	88.38	90.00	8.0	0.7	7.7	0.459	0.076	0.069	0.015	0.014
11	95.09	95.01	7.8	0.1	4.7	0.453	0.133	0.132	0.026	0.026

TABLE XV. - Continued. BLADE ELEMENT PERFORMANCE FOR ROTOR 3, 100 PERCENT DESIGN SPEED

(e) Reading 533

RP	RADI I		ABS BETAM		REL BETAM		TOTAL TEMP		TOTAL PRESS	
	IN	OUT	IN	OUT	IN	OUT	IN	OUT	IN	OUT
1	9.729	9.578	0.	34.3	61.9	55.6	518.7	616.0	14.69	22.59
2	9.510	9.386	0.	33.4	61.7	54.0	518.7	611.6	14.69	22.98
3	8.598	8.620	0.	33.2	58.5	48.8	518.7	606.3	14.69	22.95
4	8.127	8.237	0.	39.8	57.0	53.2	518.7	595.7	14.69	19.92
5	8.020	8.142	0.	41.0	56.6	57.3	518.7	593.5	14.69	18.75
6	7.893	8.046	0.	41.6	56.1	57.8	518.7	595.5	14.69	18.45
7	7.772	7.950	0.	41.2	55.6	53.4	518.7	598.6	14.69	19.15
8	7.652	7.854	0.	39.5	55.1	48.7	518.7	601.4	14.69	20.07
9	6.665	7.089	0.	35.2	51.6	35.3	518.7	600.1	14.69	23.01
10	5.558	6.323	0.	38.2	50.0	23.2	518.7	602.4	14.69	23.90
11	5.240	6.131	0.	40.1	49.3	18.6	518.7	606.4	14.69	24.14

RP	ABS VEL		REL VEL		MERID VEL		TANG VEL		WHEEL SPEED	
	IN	OUT	IN	OUT	IN	OUT	IN	OUT	IN	OUT
1	721.7	753.3	1533.8	1100.1	721.7	622.0	0.	424.9	1353.4	1332.4
2	712.5	768.8	1502.6	1091.5	712.5	642.0	0.	423.0	1322.9	1305.7
3	730.7	795.5	1399.6	1011.3	730.7	665.7	0.	435.4	1193.7	1196.8
4	733.8	685.7	1346.3	879.3	733.8	526.4	0.	439.7	1128.7	1144.0
5	735.2	617.9	1335.0	862.4	735.2	466.1	0.	405.7	1114.3	1131.3
6	737.9	604.1	1323.3	848.9	737.9	451.8	0.	401.1	1098.5	1119.8
7	737.9	660.6	1307.6	833.2	737.9	497.0	0.	435.4	1079.5	1104.2
8	742.1	720.3	1296.9	842.3	742.1	555.6	0.	458.6	1063.6	1091.7
9	735.4	853.5	1183.0	854.6	735.4	697.6	0.	491.8	926.6	985.5
10	646.9	919.4	1007.3	786.1	646.9	722.5	0.	568.9	772.2	878.4
11	626.5	946.1	961.0	763.7	626.5	723.9	0.	609.4	728.7	852.6

RP	ABS MACH NO		REL MACH NO		MERID MACH NO		MERID VEL R	PEAK SS MACH NO	EFF
	IN	OUT	IN	OUT	IN	OUT			
1	0.675	0.644	1.435	0.941	0.675	0.532	0.862	1.585	0.697
2	0.666	0.661	1.404	0.939	0.666	0.552	0.901	1.598	0.761
3	0.685	0.690	1.311	0.877	0.685	0.577	0.911	1.615	0.803
4	0.688	0.593	1.262	0.760	0.688	0.455	0.717	1.590	0.612
5	0.689	0.532	1.251	0.742	0.689	0.401	0.634	1.586	0.501
6	0.692	0.518	1.241	0.729	0.692	0.388	0.612	1.578	0.453
7	0.692	0.568	1.226	0.717	0.692	0.428	0.673	1.567	0.510
8	0.696	0.622	1.217	0.727	0.696	0.480	0.749	1.557	0.585
9	0.689	0.750	1.109	0.751	0.689	0.613	0.949	1.480	0.871
10	0.600	0.813	0.934	0.695	0.600	0.639	1.117	1.359	0.923
11	0.580	0.837	0.889	0.676	0.580	0.640	1.156	1.276	0.901

RP	PERCENT SPAN		INCIDENCE		DEV	D-FACT	LOSS COEFF		LOSS PARAM	
	IN	OUT	MEAN	SS			TOT	PROF	TOT	PROF
1	3.19	4.99	0.2	-2.0	8.8	0.384	0.220	0.115	0.046	0.024
2	7.68	10.00	1.1	-1.4	7.6	0.374	0.173	0.070	0.037	0.015
3	26.35	30.01	2.9	-1.2	4.4	0.380	0.148	0.057	0.032	0.012
4	35.99	40.01	3.7	-1.2	12.2	0.450	0.270	0.192	0.051	0.036
5	38.18	42.49	3.9	-1.1	17.2	0.449	0.337	0.261	0.056	0.044
6	40.78	45.00	4.0	-1.1	18.7	0.452	0.379	0.307	0.062	0.050
7	43.25	47.51	4.1	-1.2	15.3	0.464	0.360	0.292	0.065	0.052
8	45.71	50.01	4.1	-1.4	11.6	0.457	0.321	0.256	0.063	0.050
9	65.92	69.99	4.7	-1.8	7.7	0.387	0.118	0.082	0.029	0.017
10	88.58	90.00	5.7	-1.6	8.2	0.350	0.093	0.086	0.019	0.017
11	95.09	95.01	5.1	-2.3	7.3	0.344	0.135	0.134	0.026	0.026

TABLE XV. - Concluded. BLADE ELEMENT PERFORMANCE FOR ROTOR 3, 100 PERCENT DESIGN SPEED

(f) Reading 551

RP	RADII		ABS BETAM		REL BETAM		TOTAL TEMP		TOTAL PRESS	
	IN	OUT	IN	OUT	IN	OUT	IN	OUT	IN	OUT
1	9.729	9.578	0.	50.5	63.6	52.6	519.7	664.1	14.69	28.59
2	9.510	9.386	0.	48.9	63.5	51.6	518.7	653.4	14.69	28.67
3	8.598	8.620	0.	47.9	60.6	45.8	518.7	643.5	14.69	28.15
4	8.127	8.237	0.	51.6	59.4	45.0	518.7	640.4	14.69	26.82
5	8.020	8.142	0.	53.2	59.2	46.4	518.7	637.7	14.69	26.12
6	7.893	8.046	0.	56.1	58.8	48.3	518.7	635.9	14.69	25.27
7	7.772	7.950	0.	56.2	58.5	47.1	518.7	634.2	14.69	25.23
8	7.652	7.854	0.	53.9	58.1	44.2	518.7	634.5	14.69	25.48
9	6.665	7.089	0.	47.7	55.0	32.7	518.7	622.8	14.69	26.15
10	5.558	6.323	0.	46.4	52.9	21.1	518.7	615.0	14.69	25.84
11	5.240	6.131	0.	47.7	52.3	14.7	518.7	620.4	14.69	26.25

RP	ABS VEL		REL VEL		MERID VEL		TANG VEL		WHEEL SPEED	
	IN	OUT	IN	OUT	IN	OUT	IN	OUT	IN	OUT
1	675.2	836.1	1519.8	875.4	675.2	532.0	0.	645.3	1361.5	1340.4
2	664.3	829.6	1486.8	877.2	664.3	545.1	0.	625.4	1330.1	1312.7
3	678.5	841.9	1380.4	809.6	678.5	564.3	0.	624.7	1202.2	1205.2
4	672.6	819.5	1320.2	720.3	672.6	509.4	0.	642.2	1136.0	1151.4
5	667.8	794.9	1304.2	690.8	667.8	476.0	0.	636.7	1120.3	1137.3
6	667.2	771.5	1288.2	647.2	667.2	430.6	0.	640.1	1102.0	1123.4
7	665.5	776.7	1273.8	634.6	665.5	431.6	0.	645.8	1086.1	1111.0
8	665.5	795.7	1260.2	654.3	665.5	469.3	0.	642.5	1070.1	1098.4
9	652.0	844.1	1136.1	675.9	652.0	568.5	0.	624.0	930.4	989.6
10	588.3	892.5	974.4	659.7	588.3	615.5	0.	646.2	776.8	883.7
11	565.5	935.6	925.2	651.1	565.5	629.9	0.	691.9	732.2	856.7

RP	ABS MACH NO		REL MACH NO		MERID MACH NO		MERID VEL R	PEAK SS MACH NO	EFF
	IN	OUT	IN	OUT	IN	OUT			
1	0.628	0.693	1.414	0.725	0.628	0.441	0.788	1.621	0.747
2	0.617	0.693	1.382	0.733	0.617	0.455	0.821	1.635	0.810
3	0.632	0.710	1.285	0.683	0.632	0.476	0.832	1.659	0.848
4	0.626	0.692	1.228	0.608	0.626	0.430	0.757	1.641	0.800
5	0.621	0.670	1.213	0.583	0.621	0.401	0.713	1.641	0.778
6	0.620	0.650	1.198	0.545	0.620	0.363	0.645	1.632	0.742
7	0.618	0.656	1.184	0.536	0.618	0.364	0.649	1.629	0.750
8	0.619	0.673	1.171	0.553	0.619	0.397	0.705	1.622	0.763
9	0.605	0.725	1.054	0.581	0.605	0.489	0.872	1.563	0.892
10	0.542	0.777	0.898	0.575	0.542	0.536	1.046	1.393	0.943
11	0.520	0.816	0.851	0.568	0.520	0.549	1.114	1.308	0.919

RP	PERCENT SPAN		INCIDENCE		DEV	D-FACT	LOSS TOT	COEFF PROF	LOSS TOT	PARAM PROF
	IN	OUT	MEAN	SS						
1	3.19	4.99	1.9	-0.4	5.7	0.579	0.255	0.145	0.057	0.032
2	7.68	10.00	2.9	0.3	5.3	0.561	0.189	0.081	0.042	0.018
3	26.35	30.01	4.9	0.8	1.4	0.563	0.158	0.060	0.036	0.014
4	35.99	40.01	6.1	1.2	4.0	0.608	0.214	0.130	0.048	0.029
5	38.18	42.49	6.5	1.5	6.4	0.623	0.236	0.154	0.050	0.033
6	40.78	45.00	6.7	1.6	9.1	0.651	0.274	0.196	0.056	0.040
7	43.25	47.51	7.0	1.6	9.1	0.656	0.267	0.192	0.055	0.039
8	45.71	50.01	7.1	1.7	7.1	0.634	0.258	0.186	0.055	0.040
9	65.92	69.99	8.1	1.6	5.1	0.550	0.129	0.085	0.028	0.018
10	88.58	90.00	8.5	1.2	6.2	0.476	0.083	0.075	0.017	0.015
11	95.09	95.01	8.1	0.7	3.8	0.460	0.133	0.132	0.026	0.026

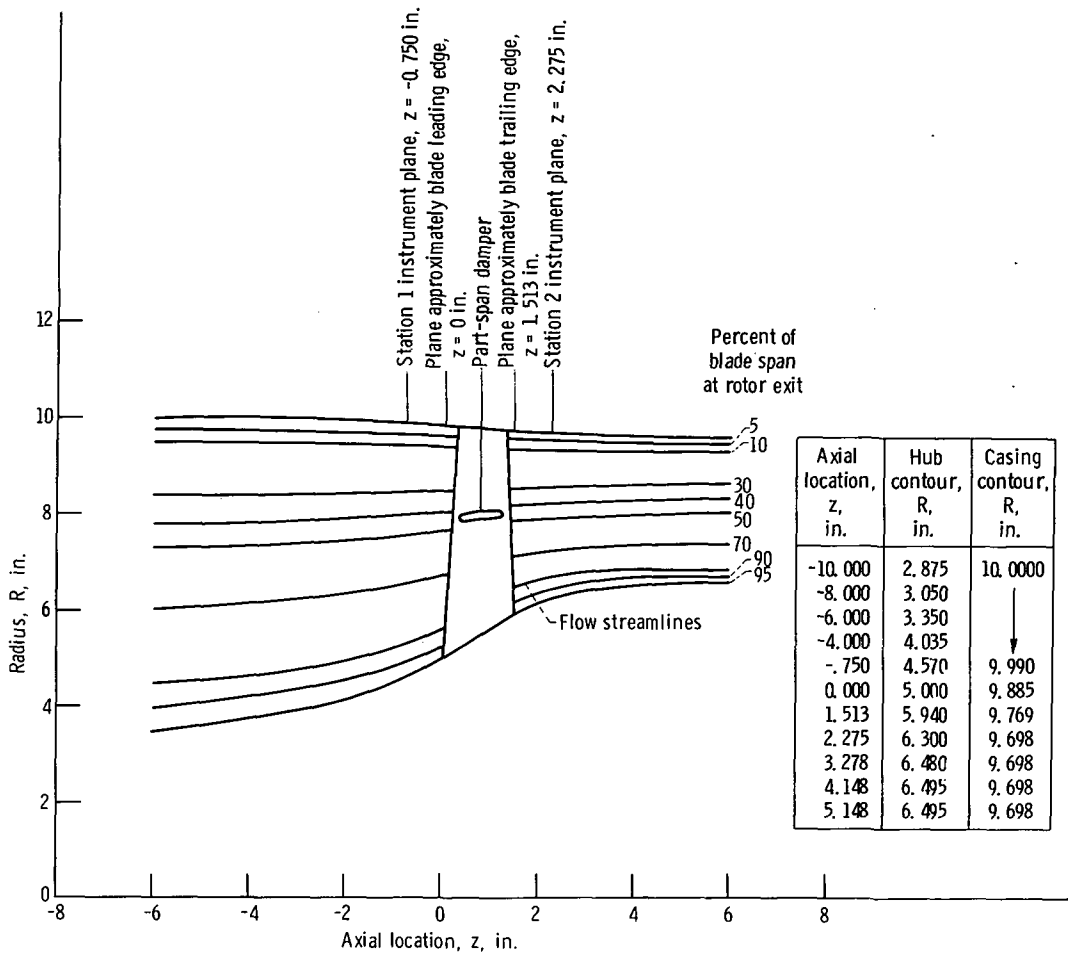

Figure 1. - Compressor flow path for rotor 3.

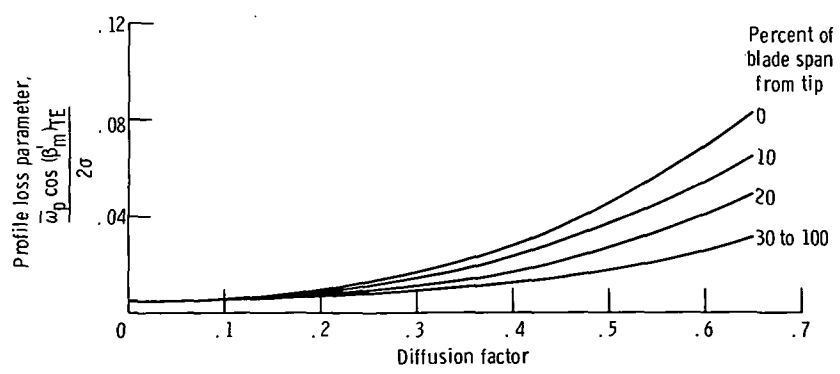
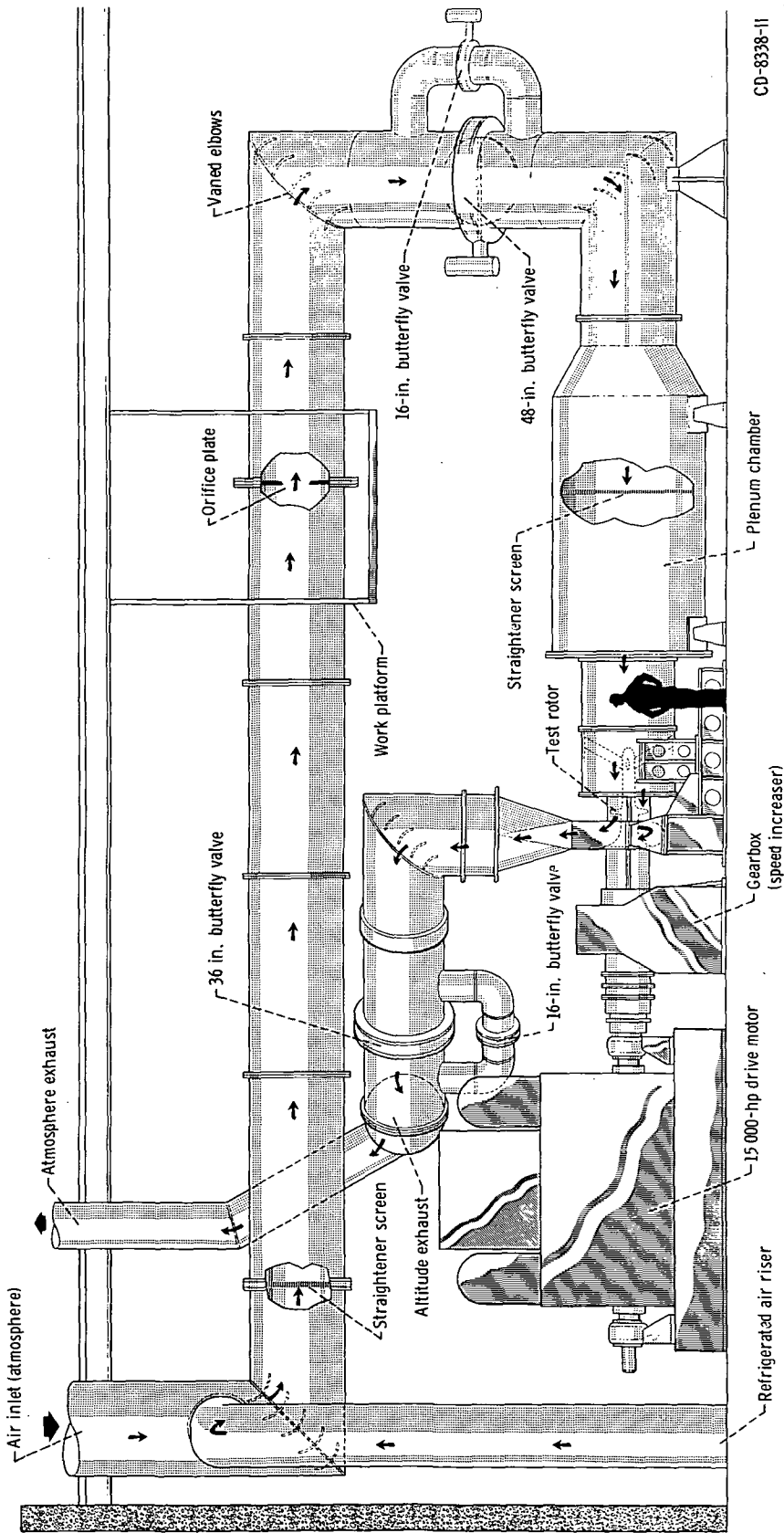

Figure 2. - Profile loss parameter as function of loading and percent span used in design of rotor 3.



CD-8338-II

Figure 3. - Compressor test facility.

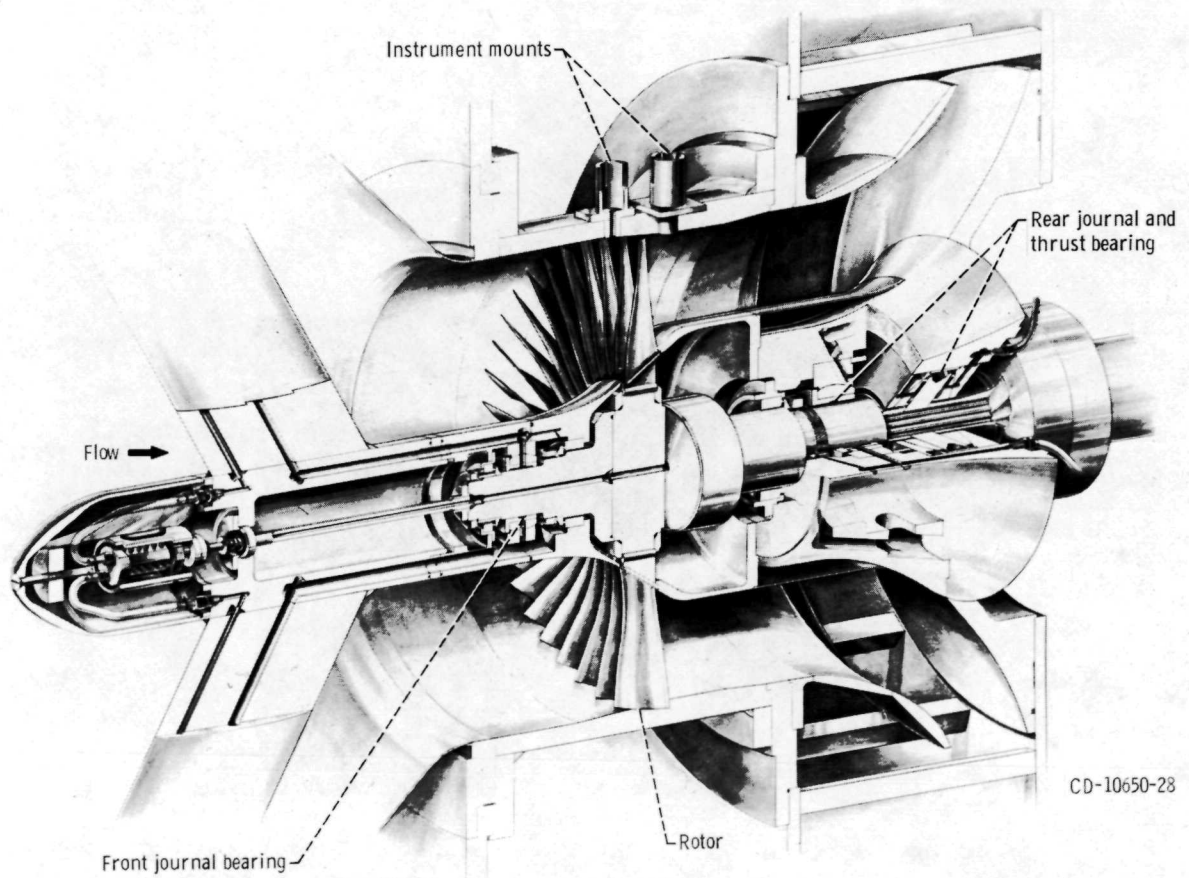

Figure 4. - Compressor assembly.

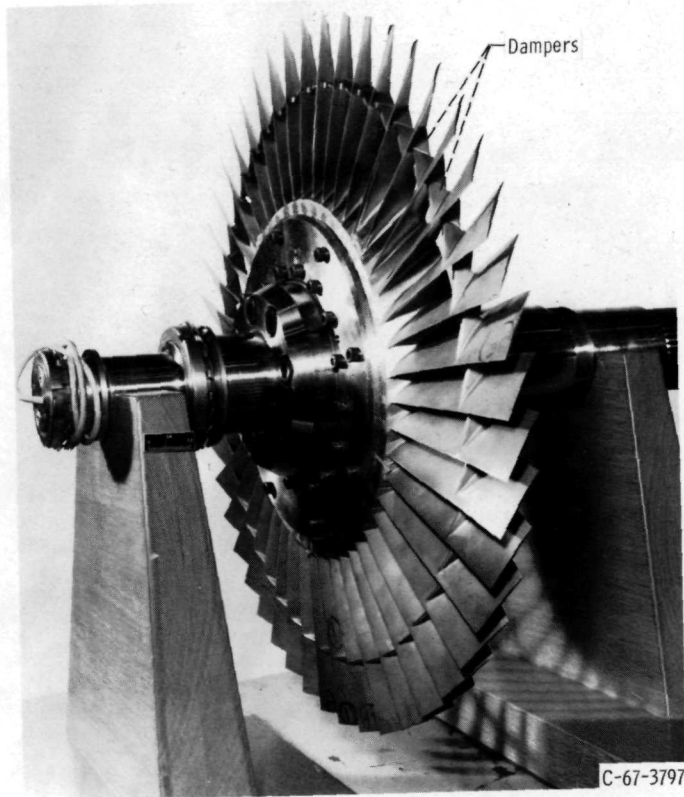
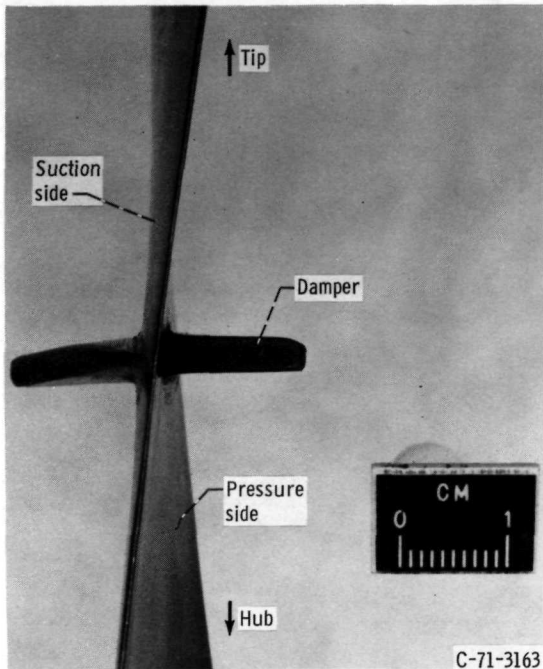
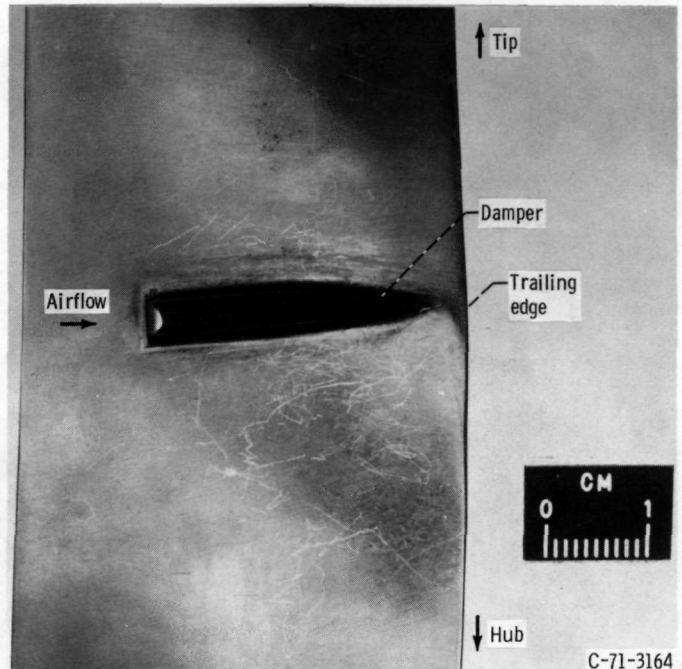

Figure 5. - Test rotor 3.



(a) Viewed from blade leading edge.



(b) Viewed from blade pressure surface.

Figure 6. - Part-span damper shroud.

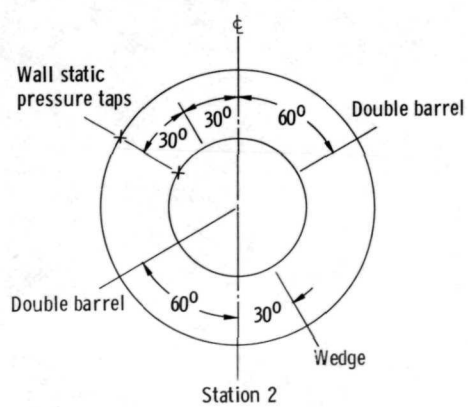
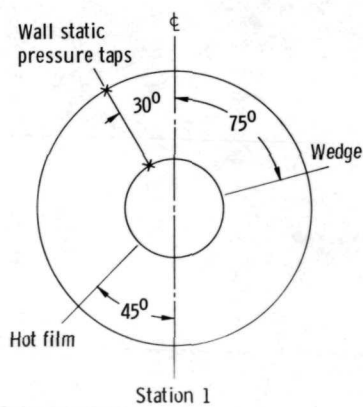
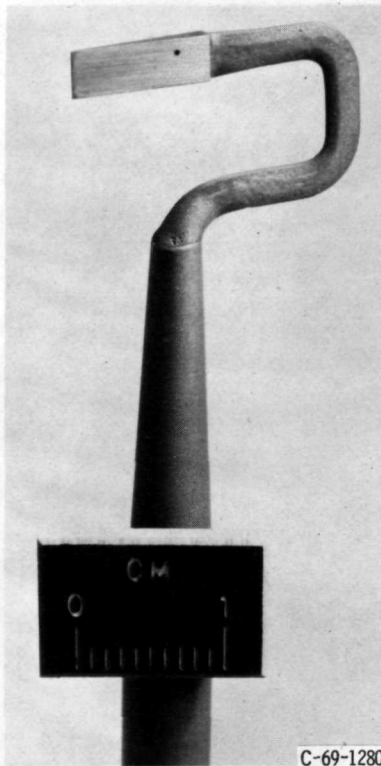
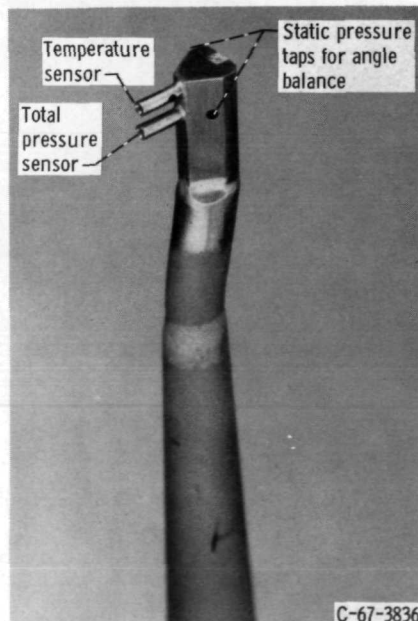

Figure 7. - Circumferential location of survey instrumentation and type of probes employed at each location.



C-69-1280

Figure 8. - Static pressure probe
(C) type; $7\frac{1}{2}^\circ$ wedge).



C-67-3836

Figure 9. - Combination total pressure, total temperature, and flow angle probe (double barrel).

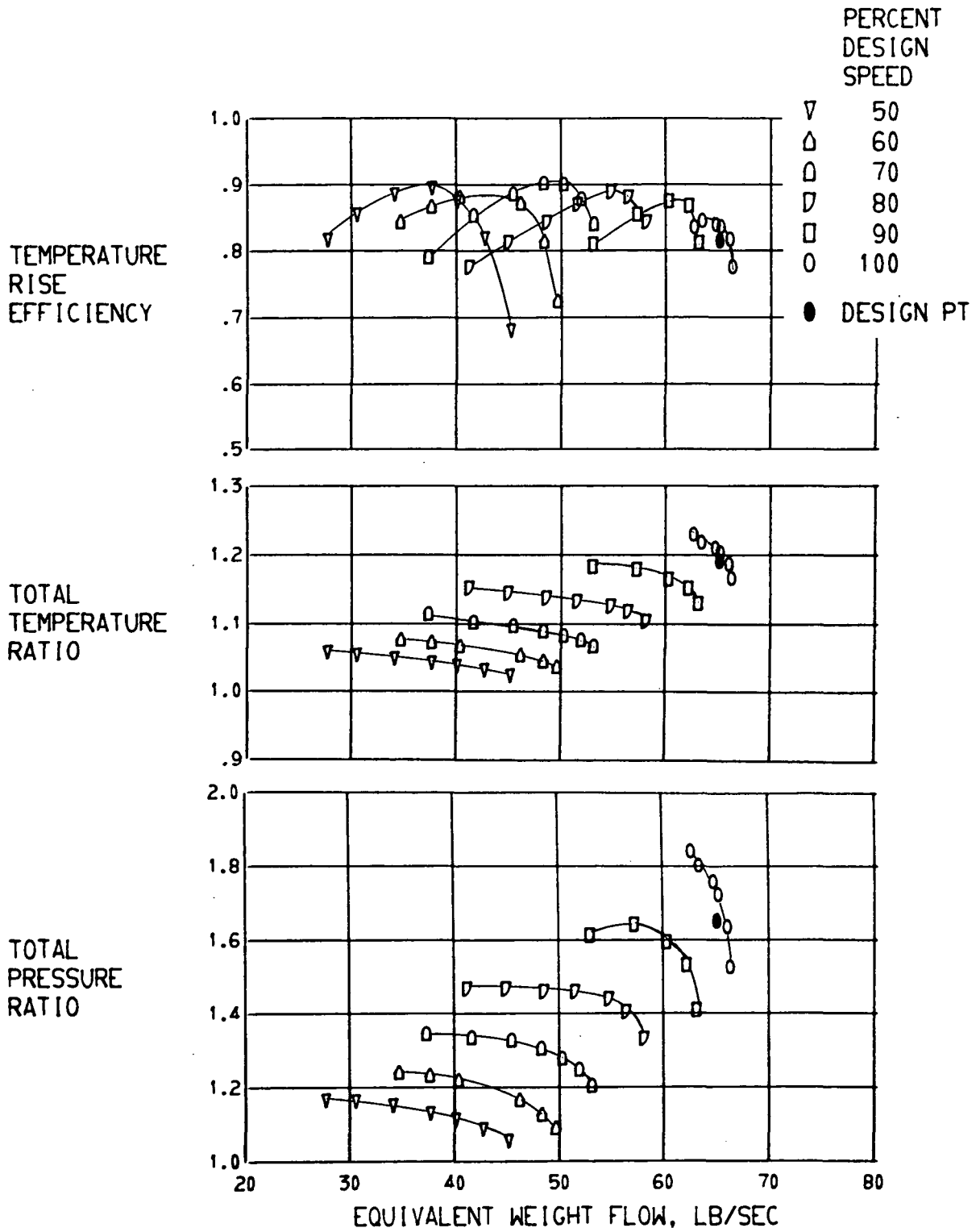

FIGURE 10. - OVERALL PERFORMANCE FOR ROTOR 3.

WEIGHT FLOW, LB/SEC	READING
▽ 65.3	530
○ 66.4	533
□ 62.7	551
--- 65.3	DESIGN

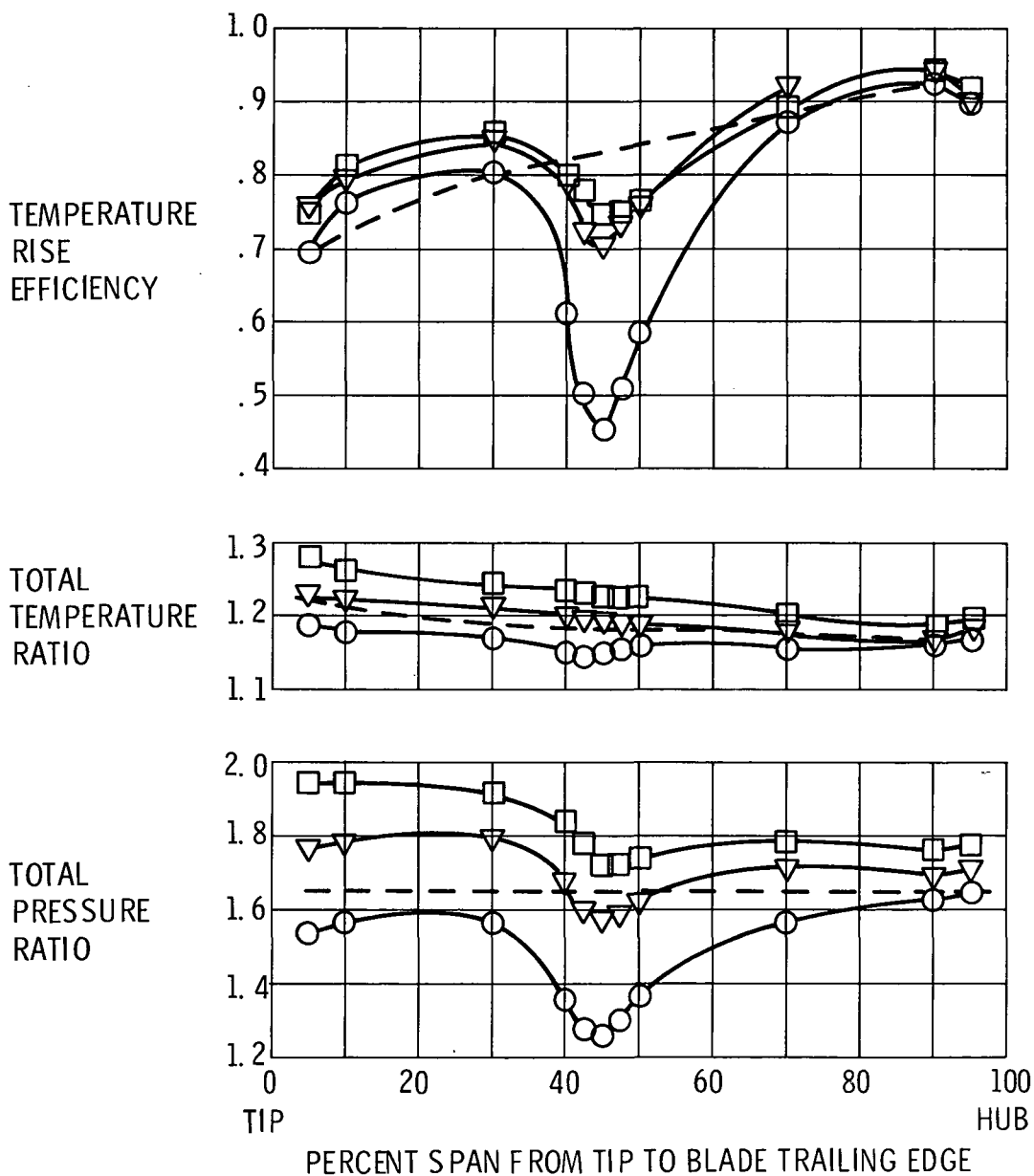

FIGURE 11. - RADIAL VARIATION OF PERFORMANCE PARAMETERS FOR ROTOR 3.

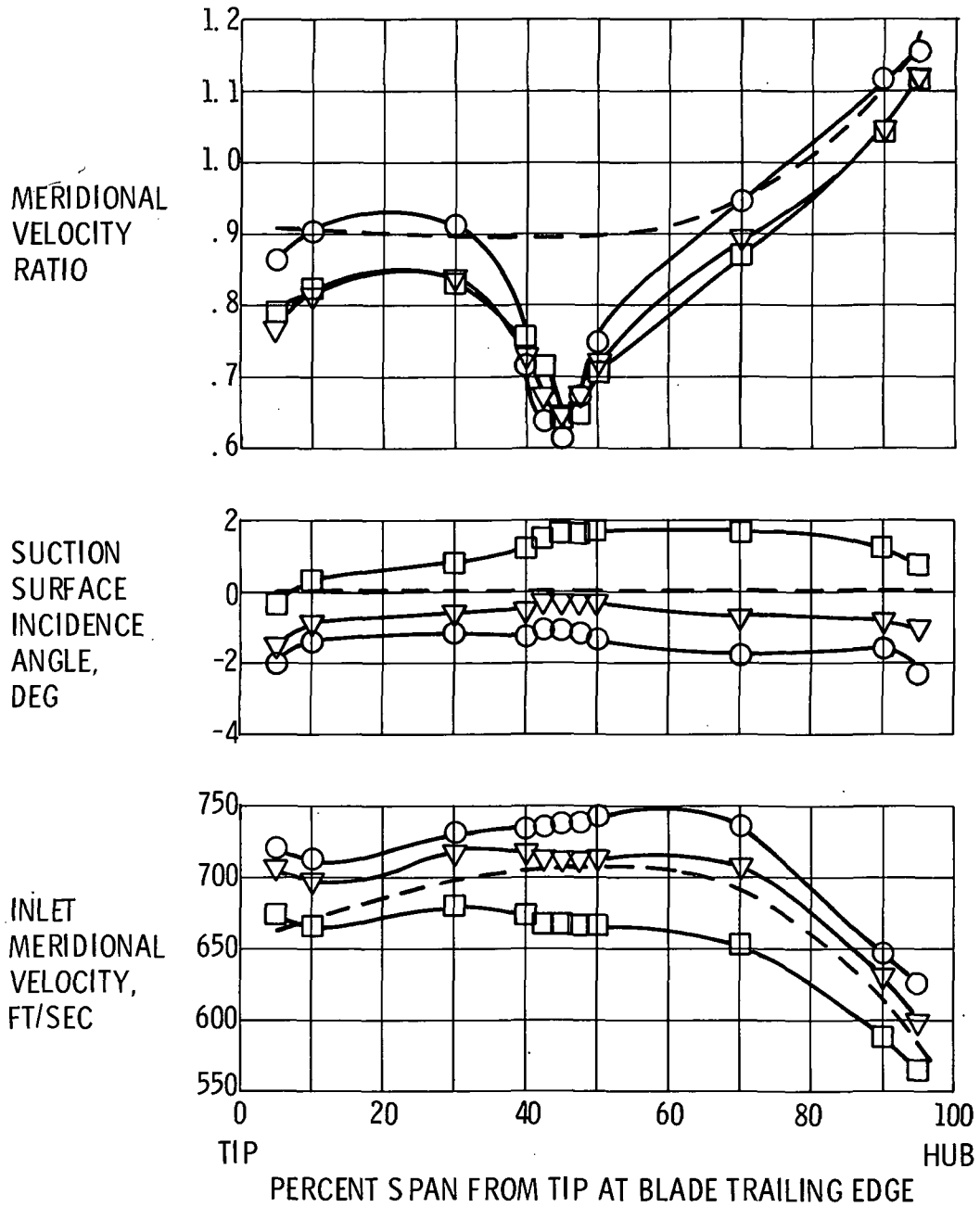

FIGURE 11. - CONTINUED.

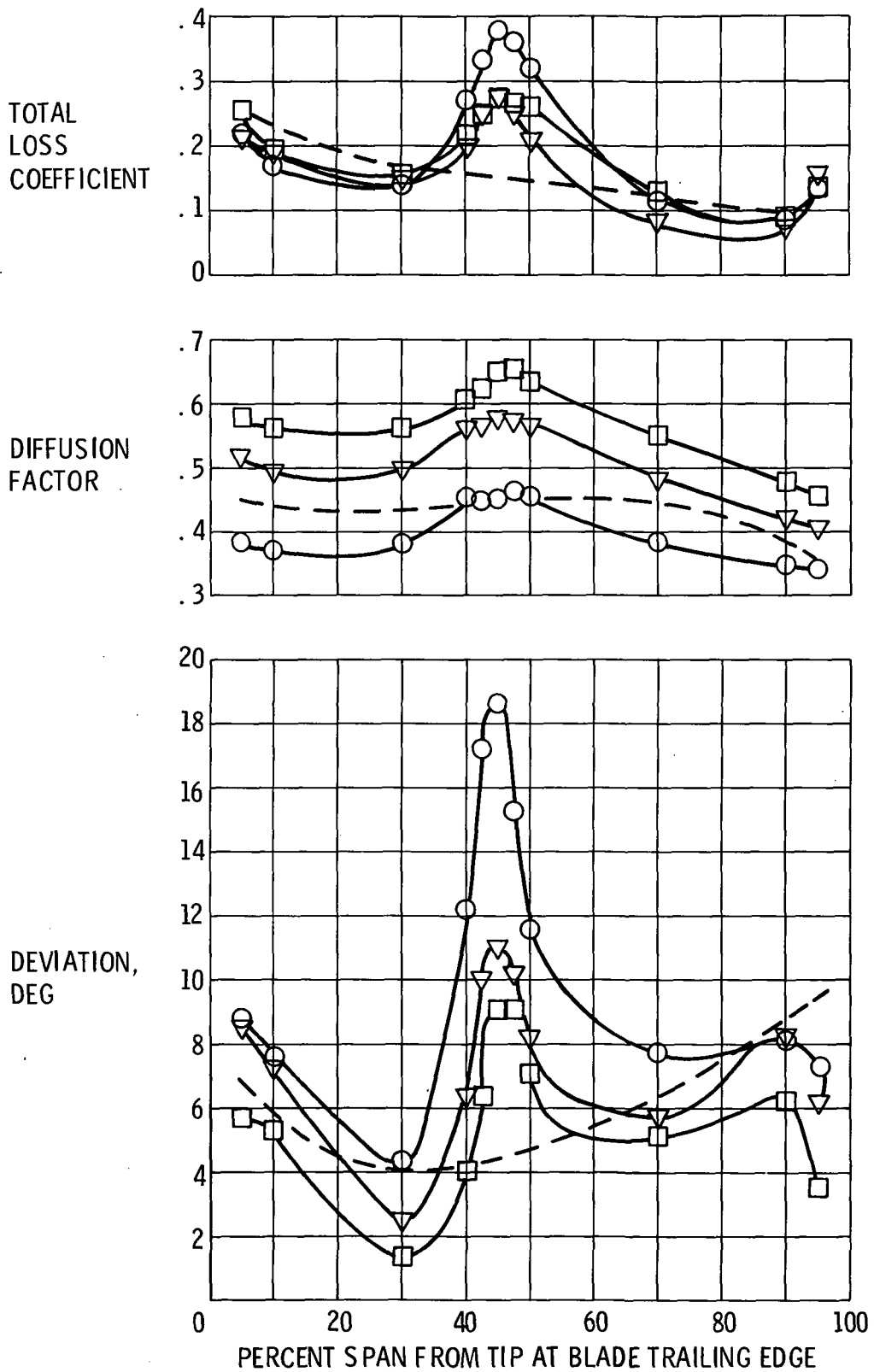
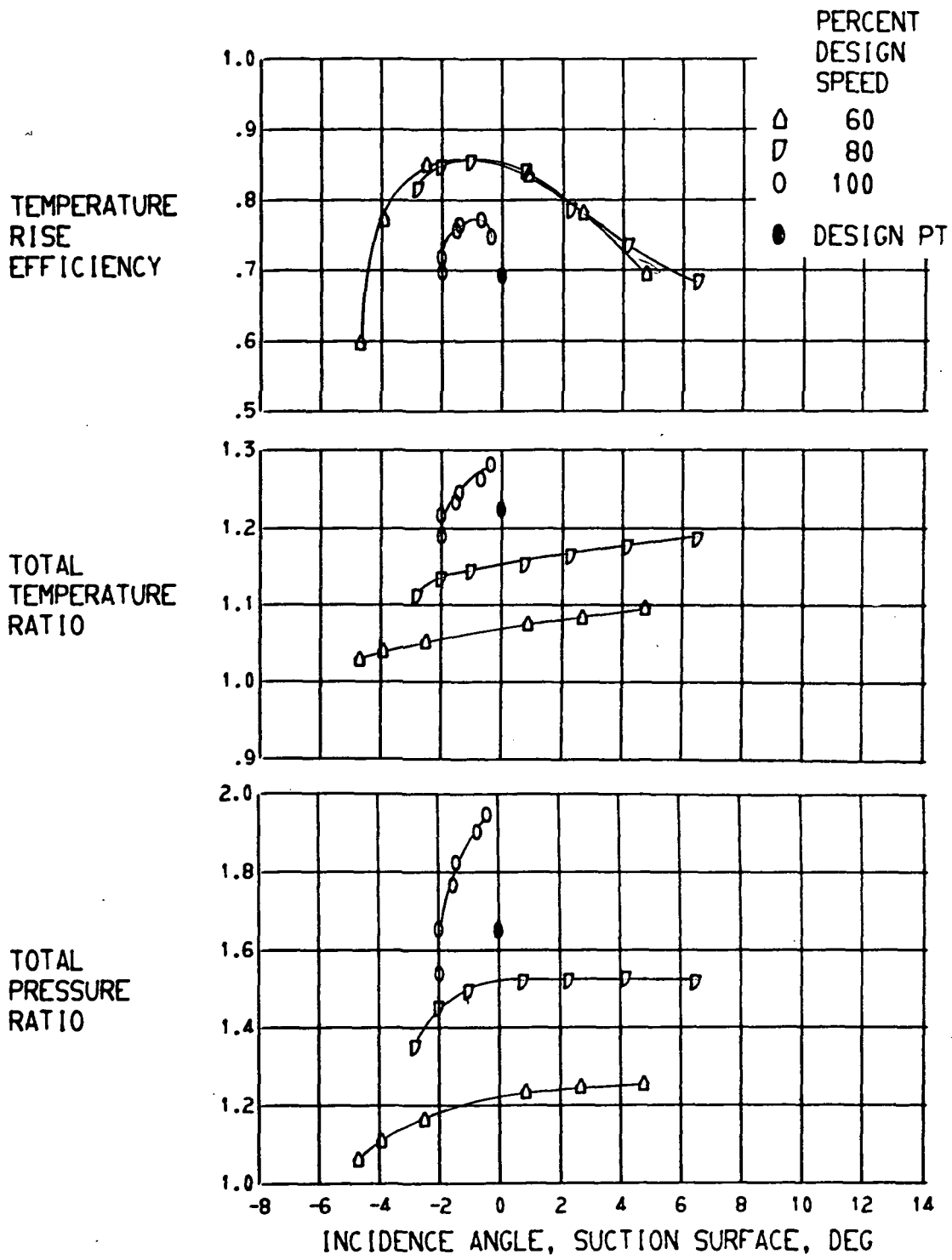
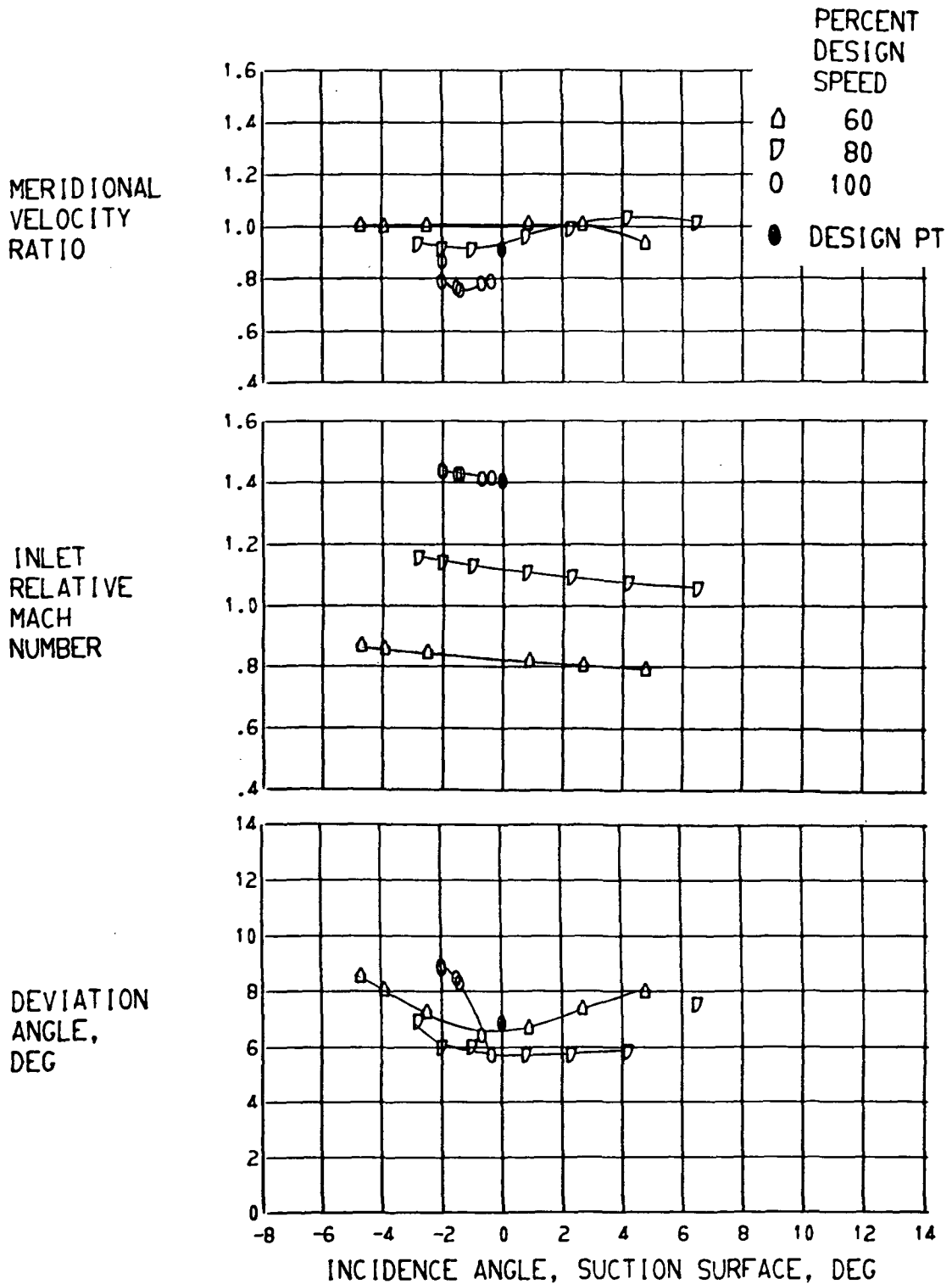

FIGURE 11. - CONCLUDED.



(A) 5.0 PERCENT SPAN.

FIGURE 12. - BLADE ELEMENT PERFORMANCE FOR ROTOR 3.



(A) CONTINUED. 5.0 PERCENT SPAN.

FIGURE 12. - BLADE ELEMENT PERFORMANCE FOR ROTOR 3.

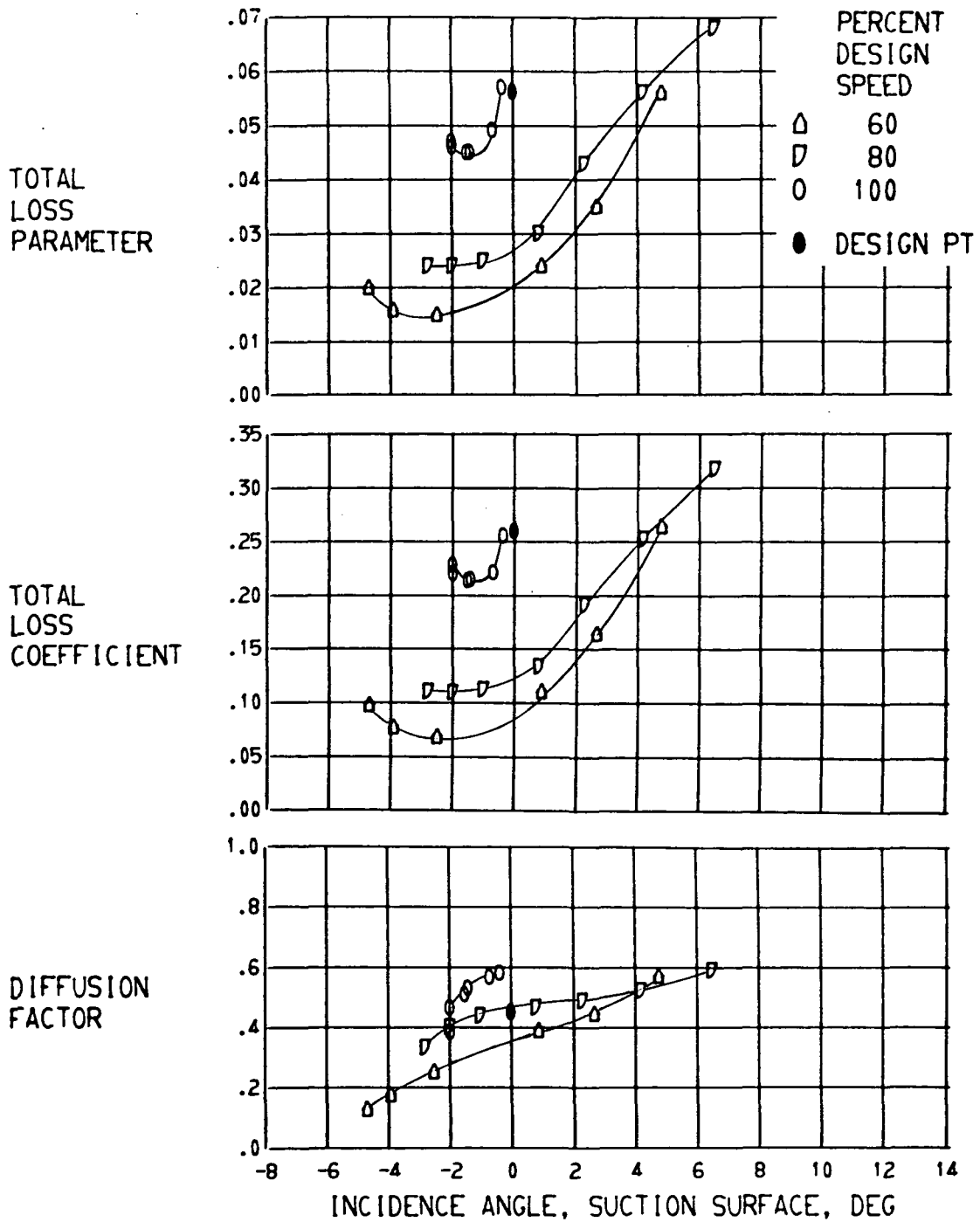

(A) CONCLUDED. 5.0 PERCENT SPAN.

FIGURE 12. - BLADE ELEMENT PERFORMANCE FOR ROTOR 3.

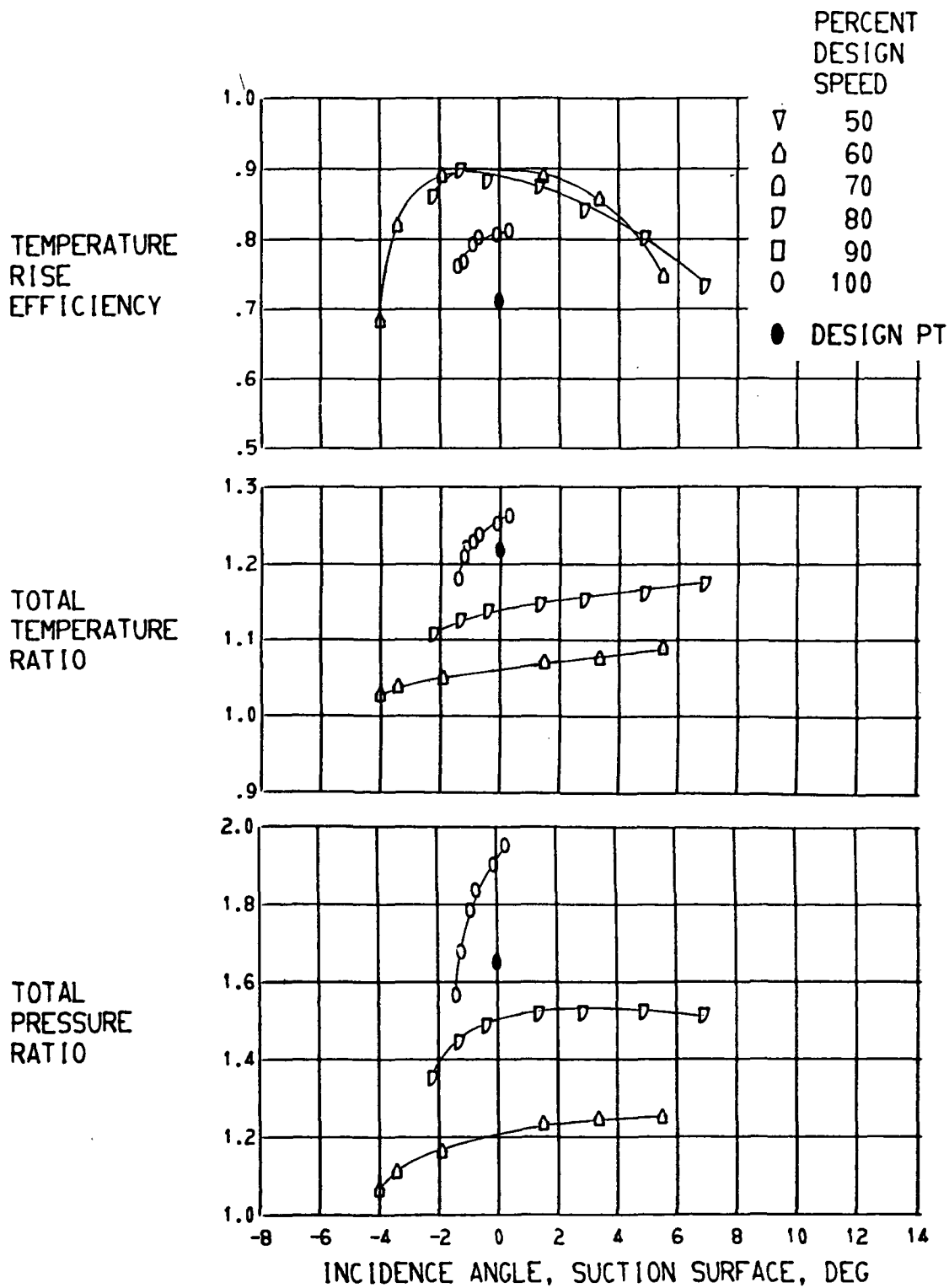

(B) 10.0 PERCENT SPAN.

FIGURE 12. - BLADE ELEMENT PERFORMANCE FOR ROTOR 3.

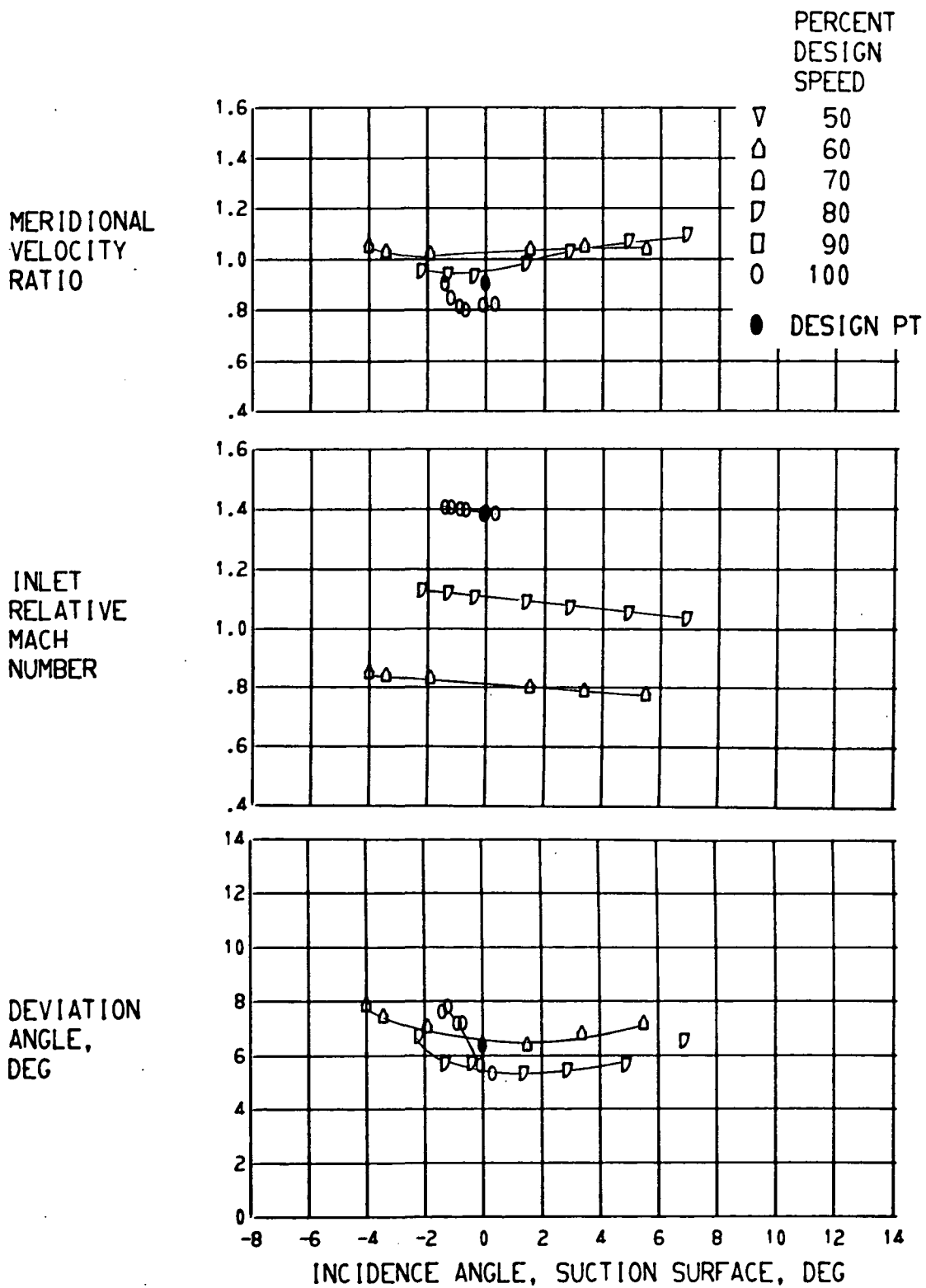

(B) CONTINUED. 10.0 PERCENT SPAN.

FIGURE 12. - BLADE ELEMENT PERFORMANCE FOR ROTOR 3.

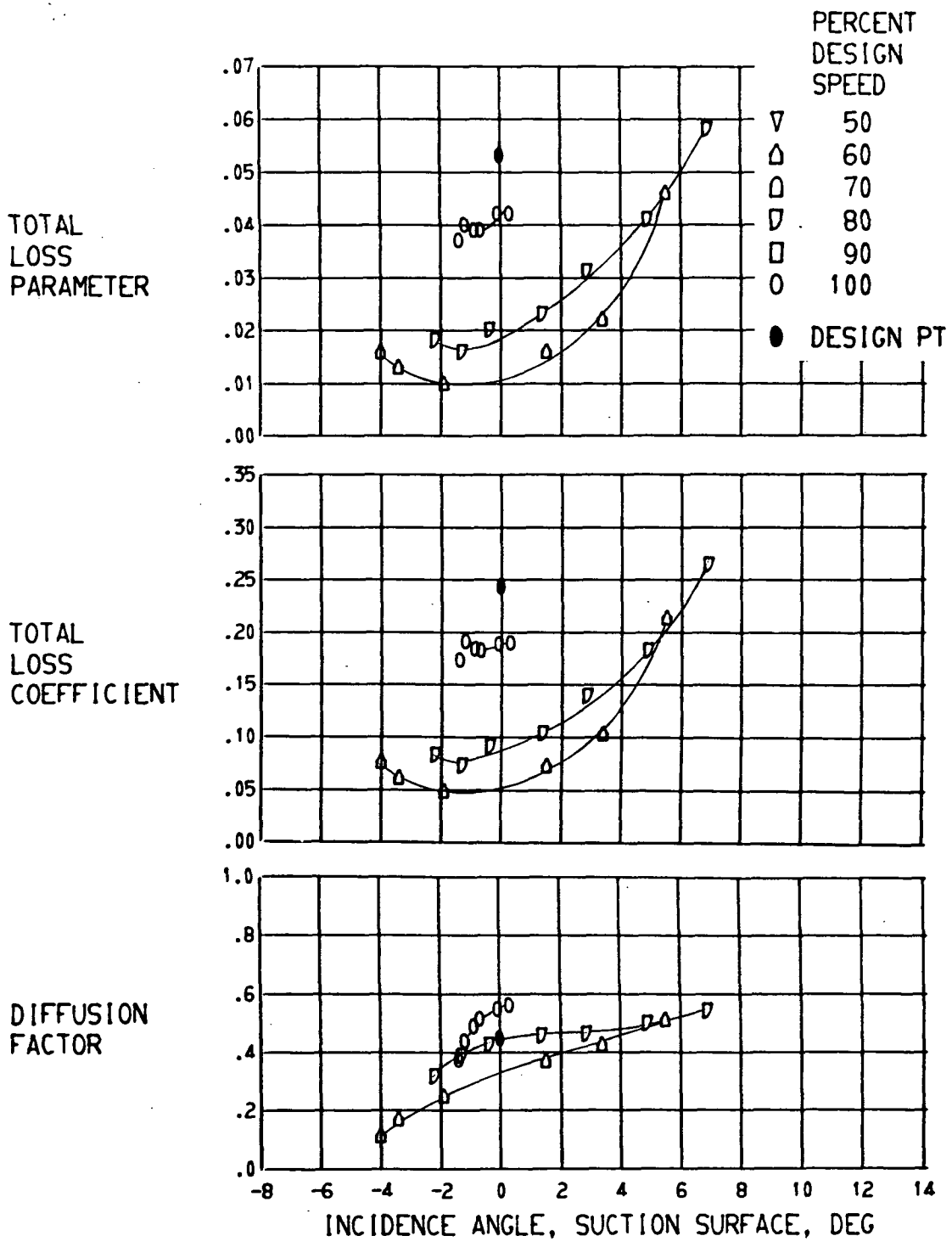

(B) CONCLUDED. 10.0 PERCENT SPAN.

FIGURE 12. - BLADE ELEMENT PERFORMANCE FOR ROTOR 3.

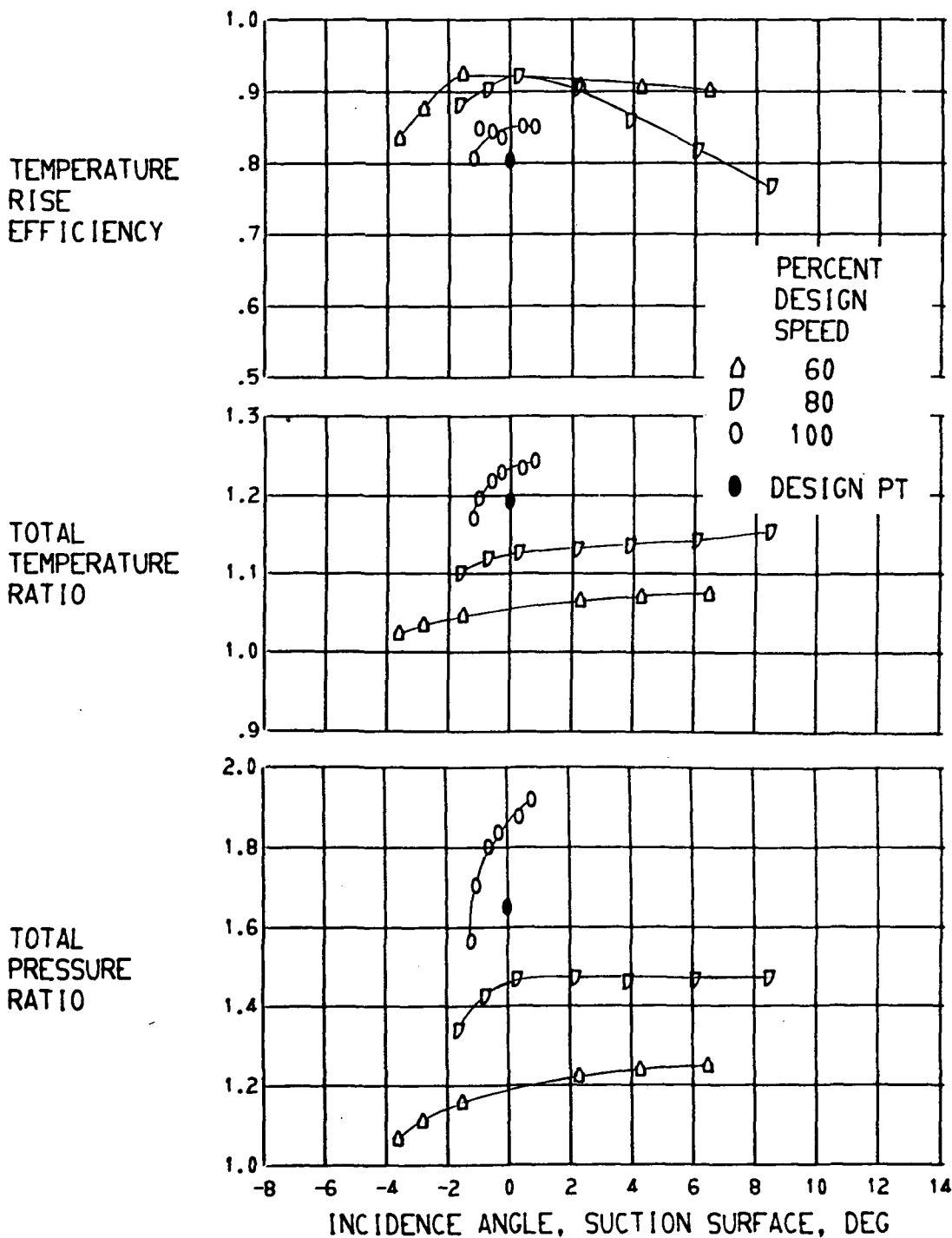

(C) 30.0 PERCENT SPAN.

FIGURE 12. - BLADE ELEMENT PERFORMANCE FOR ROTOR 3.

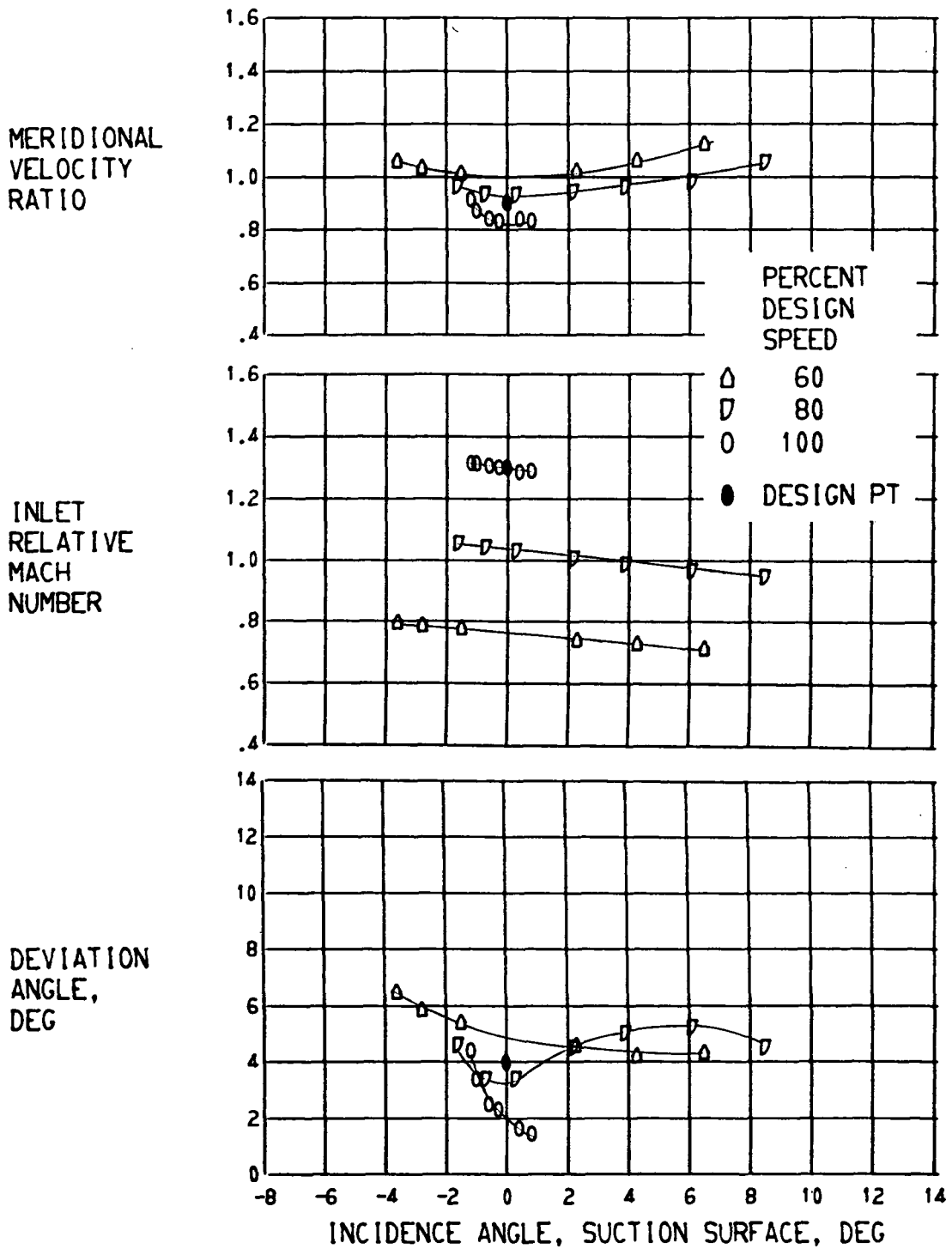

(C) CONTINUED. 30.0 PERCENT SPAN.

FIGURE 12. - BLADE ELEMENT PERFORMANCE FOR ROTOR 3.

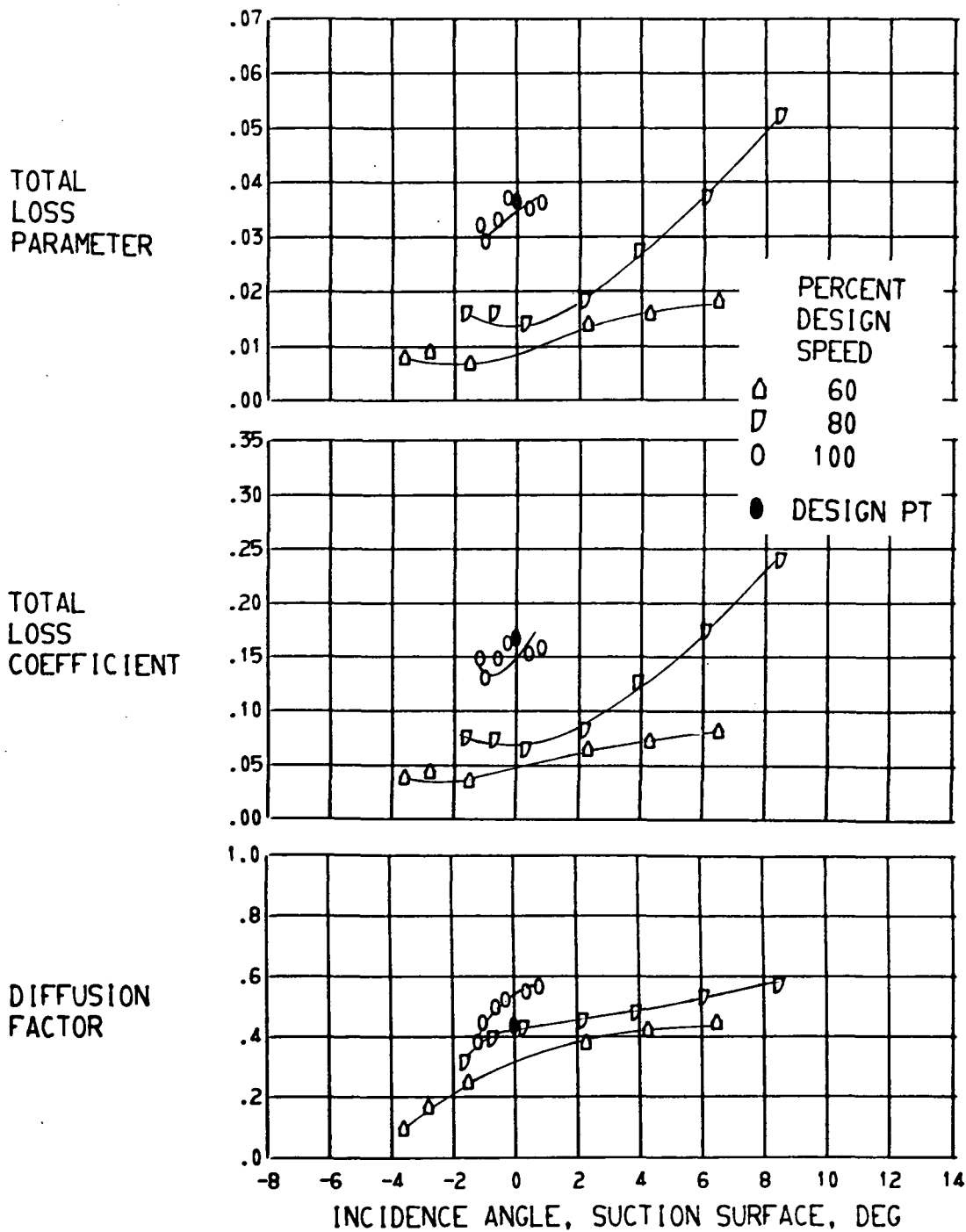

(C) CONCLUDED. 30.0 PERCENT SPAN.

FIGURE 12. - BLADE ELEMENT PERFORMANCE FOR ROTOR 3.

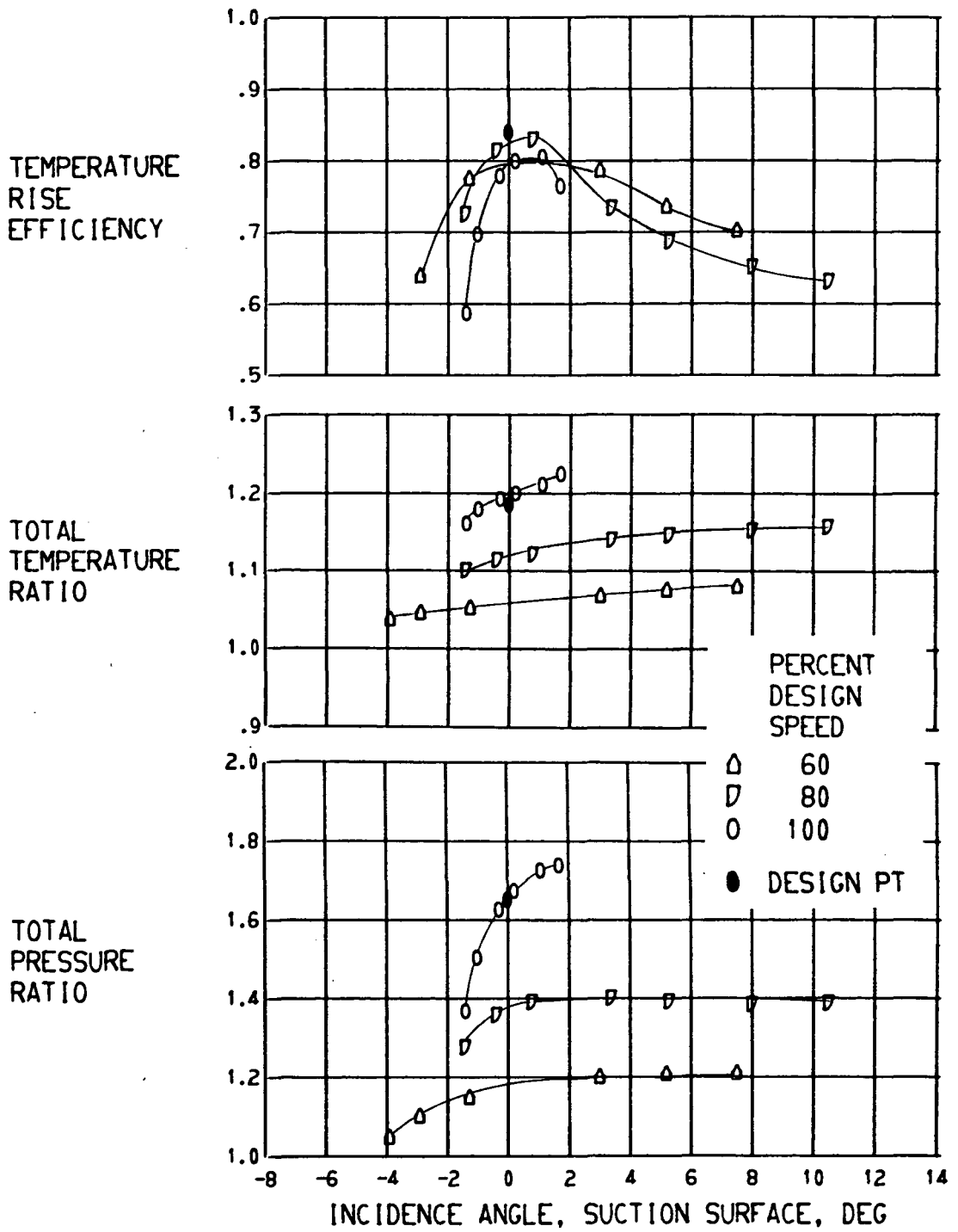

(D) 50.0 PERCENT SPAN.

FIGURE 12. - BLADE ELEMENT PERFORMANCE FOR ROTOR 3.

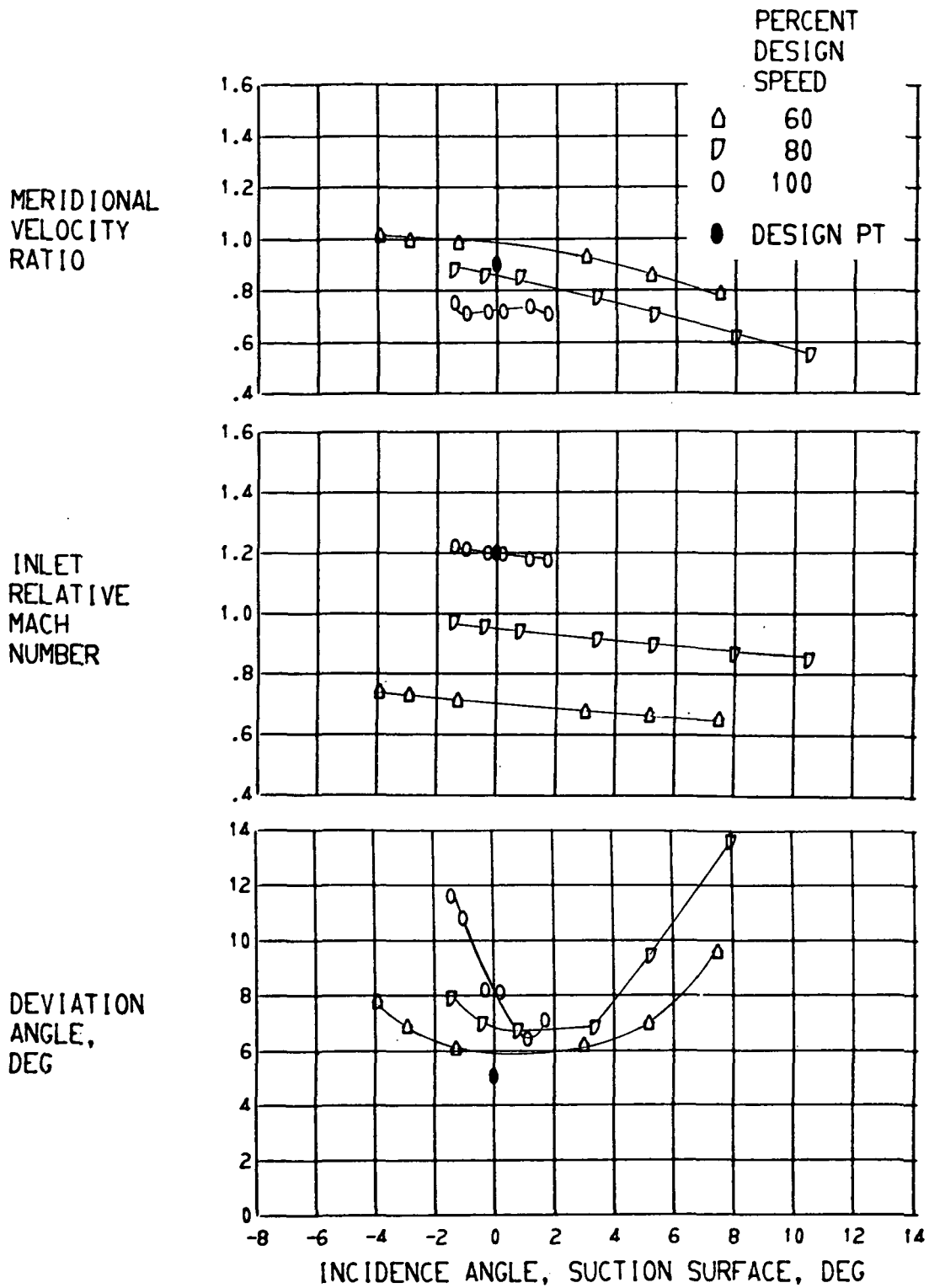

(D) CONTINUED. 50.0 PERCENT SPAN.

FIGURE 12. - BLADE ELEMENT PERFORMANCE FOR ROTOR 3.

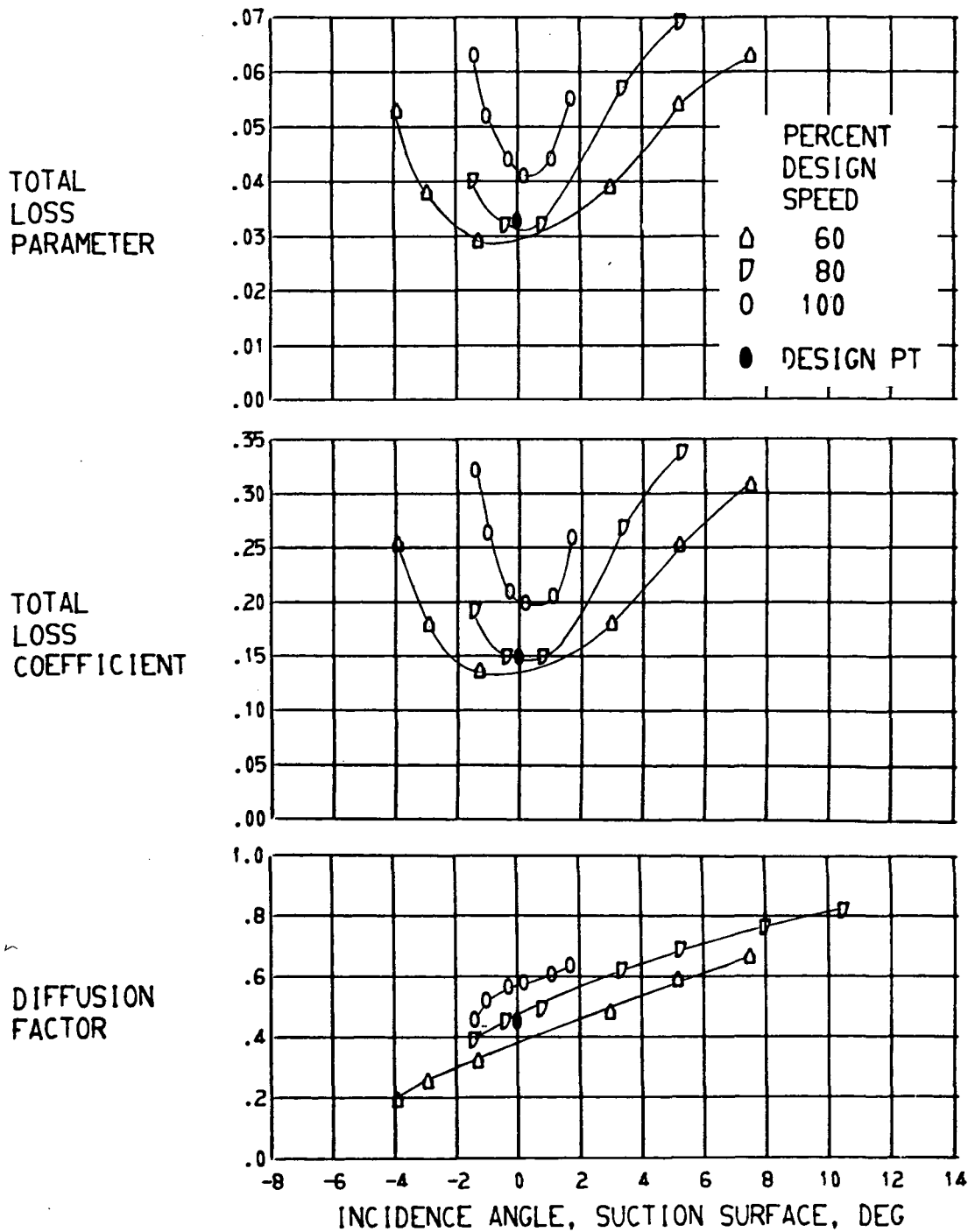

(D) CONCLUDED. 50.0 PERCENT SPAN.

FIGURE 12. - BLADE ELEMENT PERFORMANCE FOR ROTOR 3.

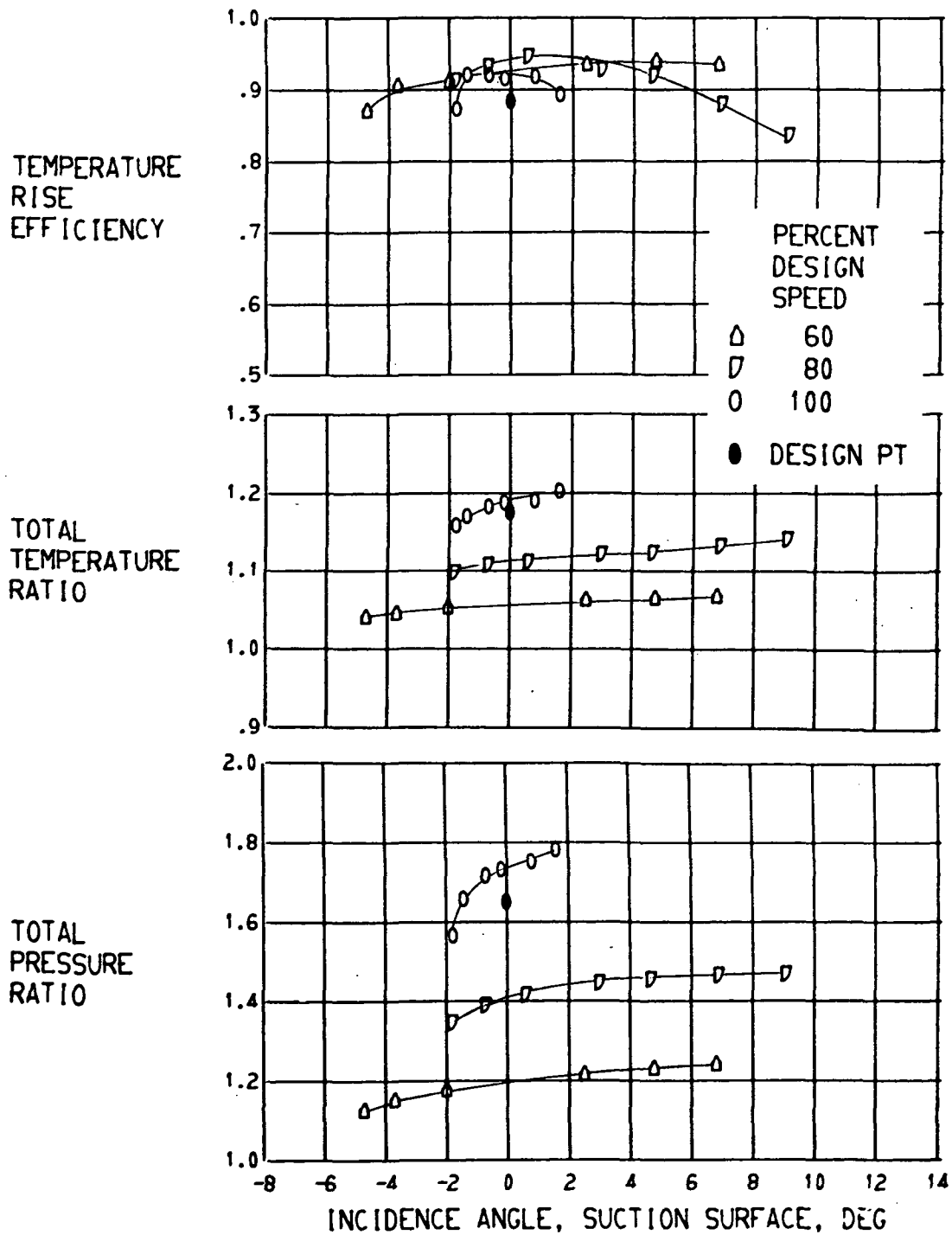

(E) 70.0 PERCENT SPAN.

FIGURE 12. - BLADE ELEMENT PERFORMANCE FOR ROTOR 3.

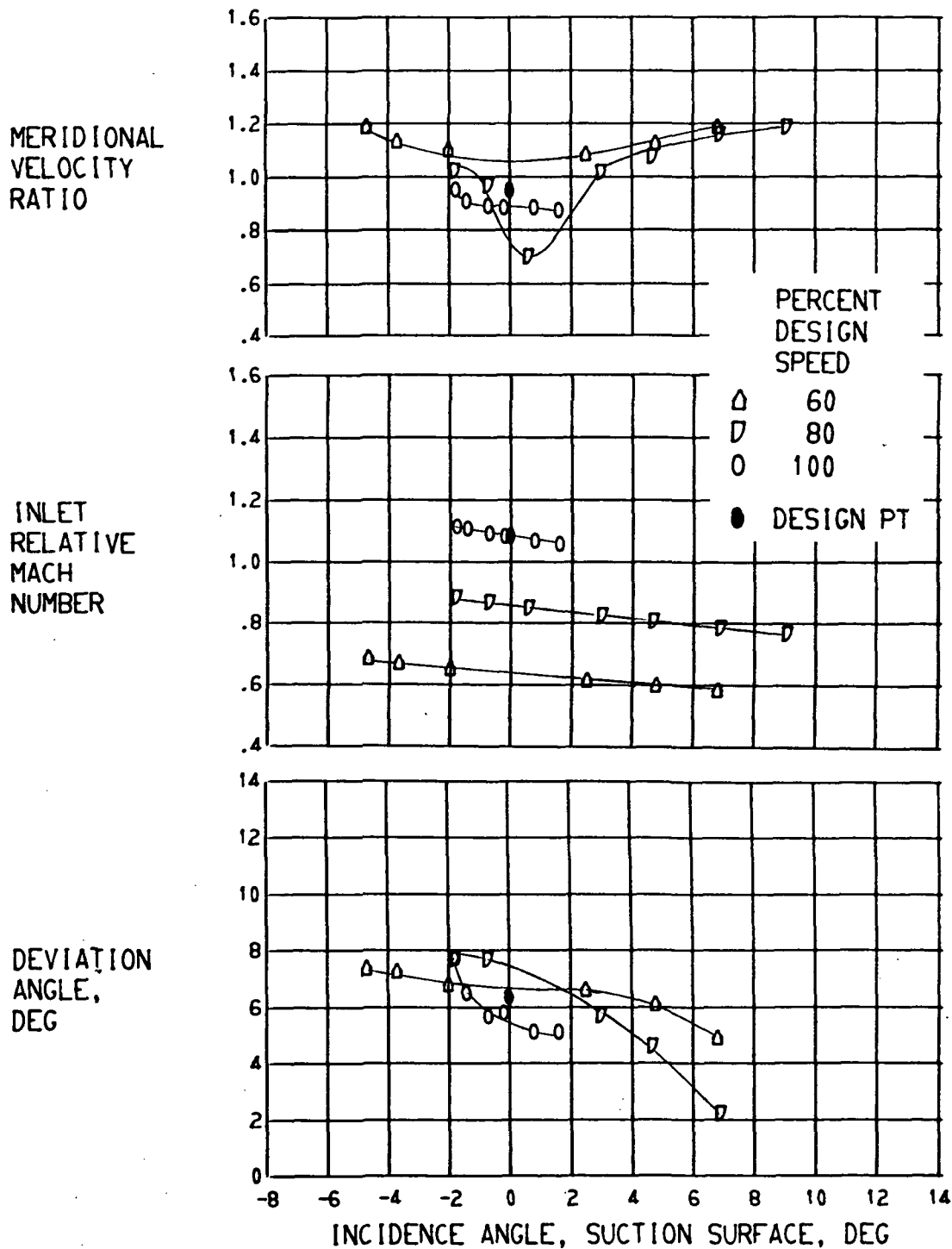

(E) CONTINUED. 70.0 PERCENT SPAN.

FIGURE 12. - BLADE ELEMENT PERFORMANCE FOR ROTOR 3.

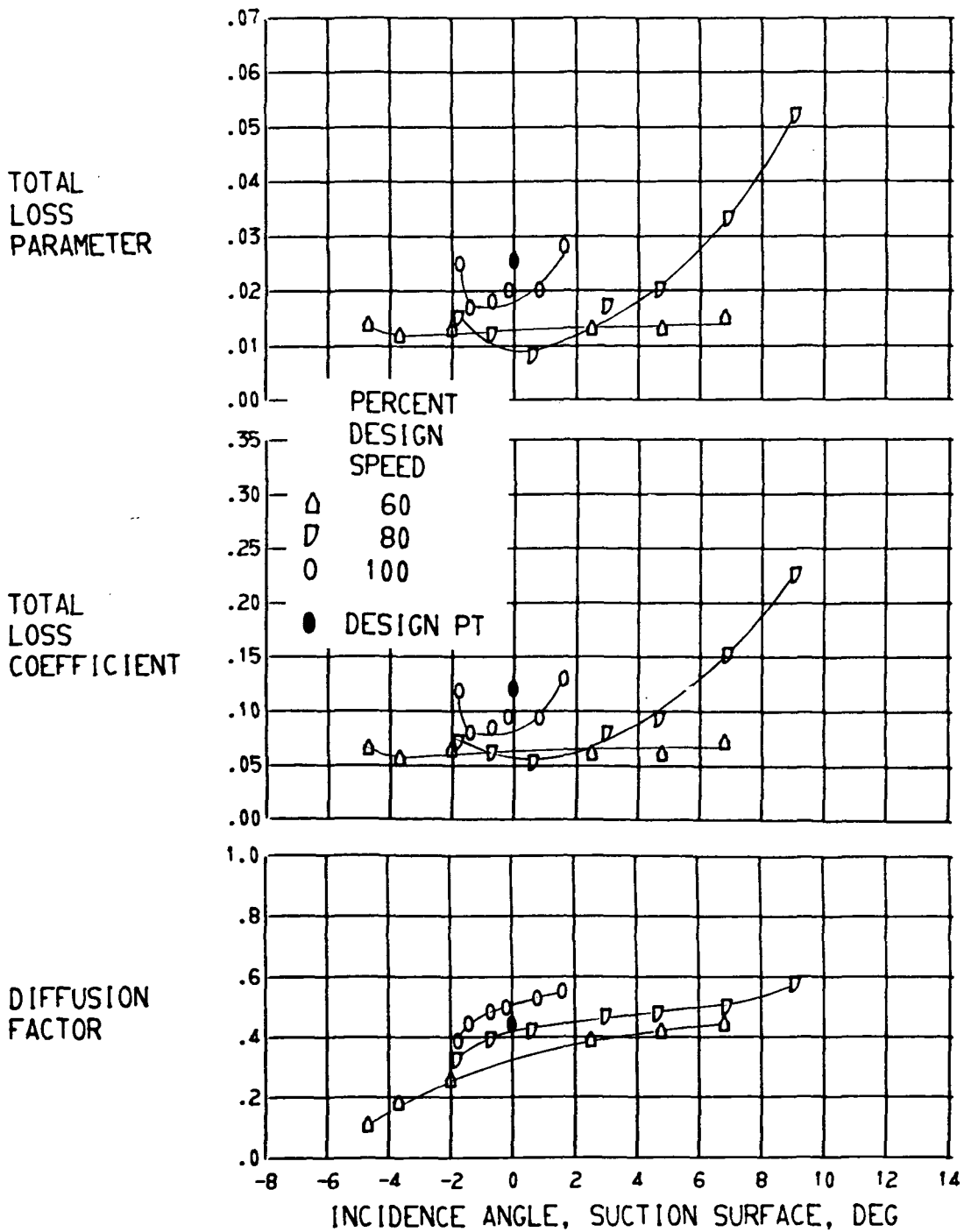

(E) CONCLUDED. 70.0 PERCENT SPAN.

FIGURE 12. - BLADE ELEMENT PERFORMANCE FOR ROTOR 3.

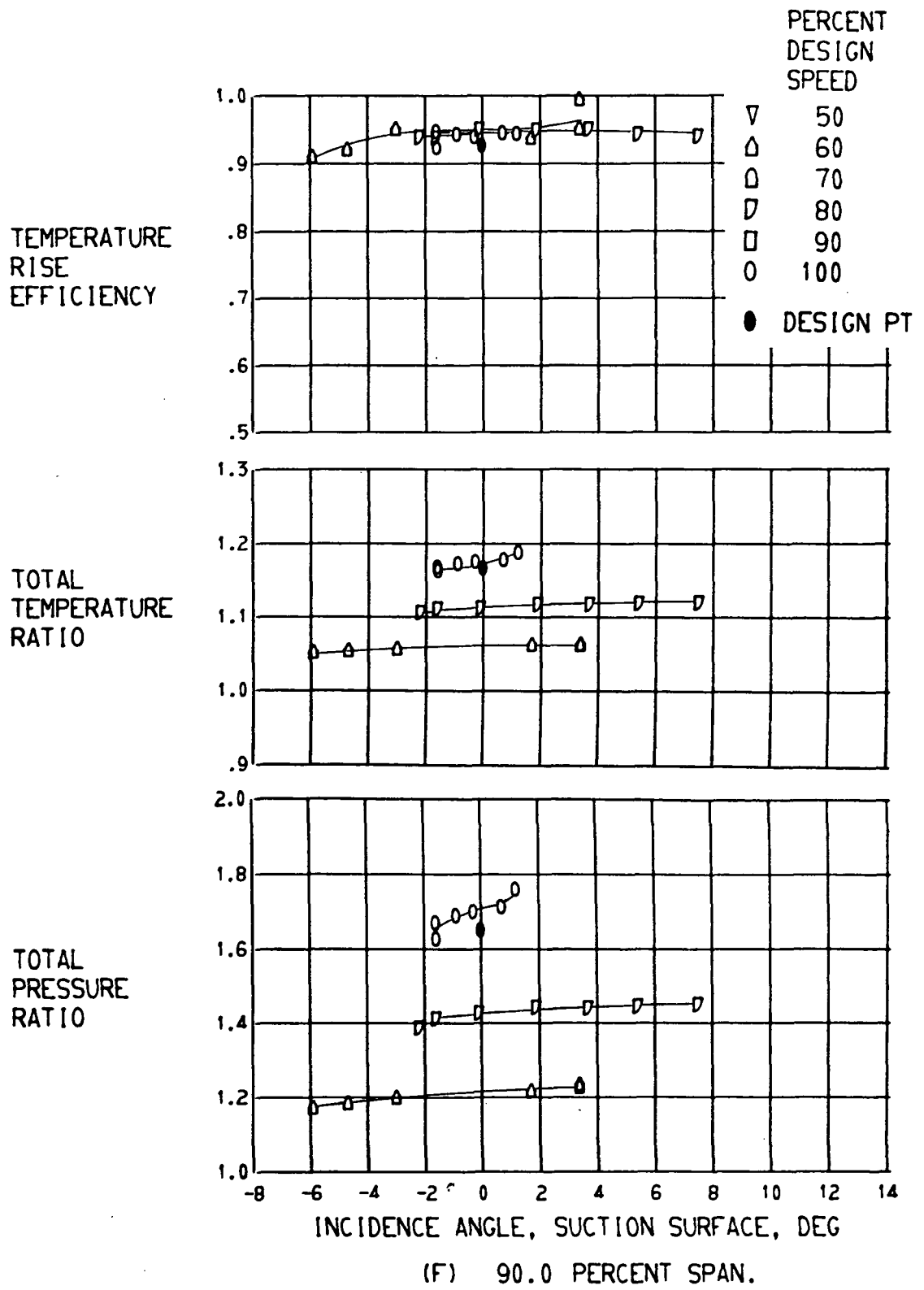
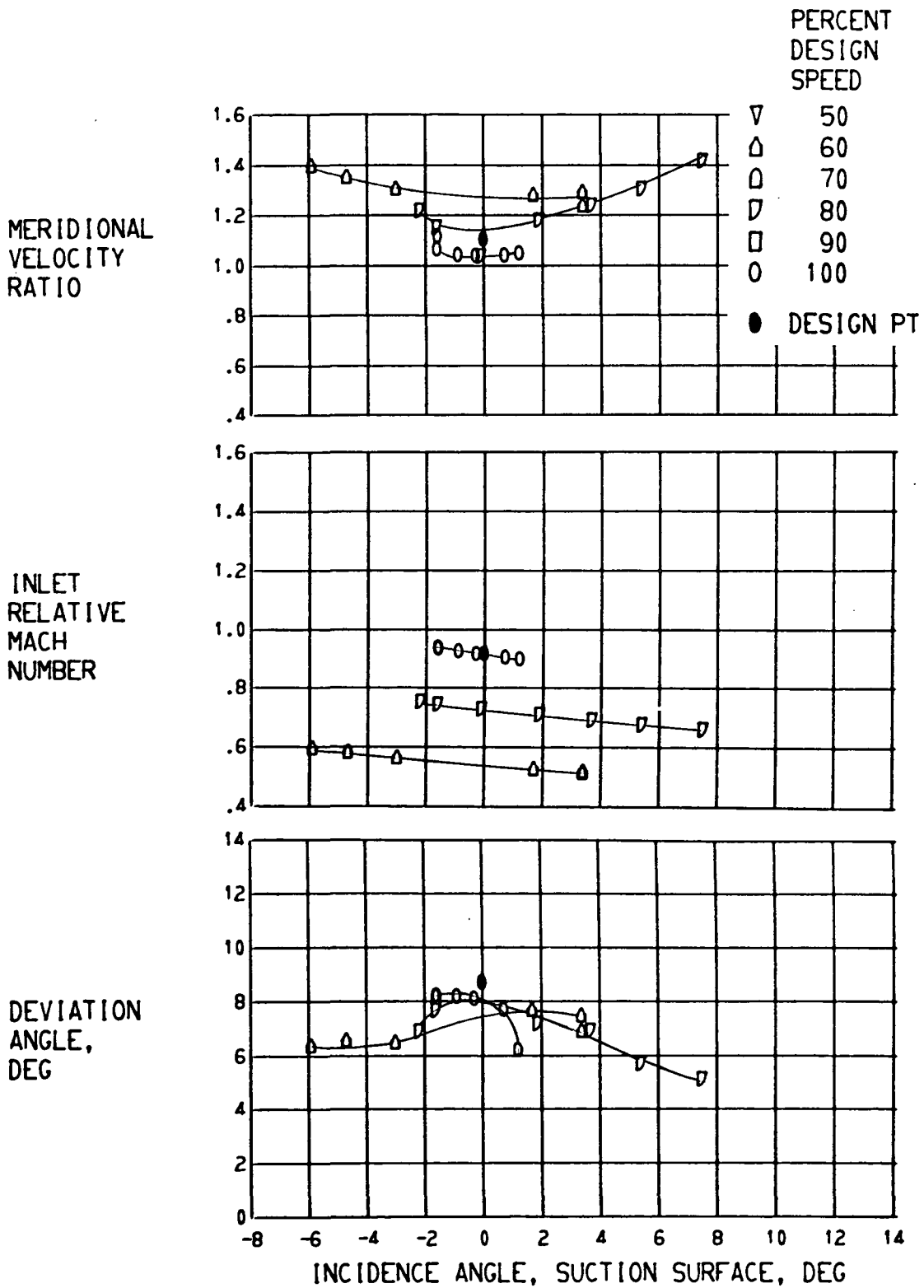
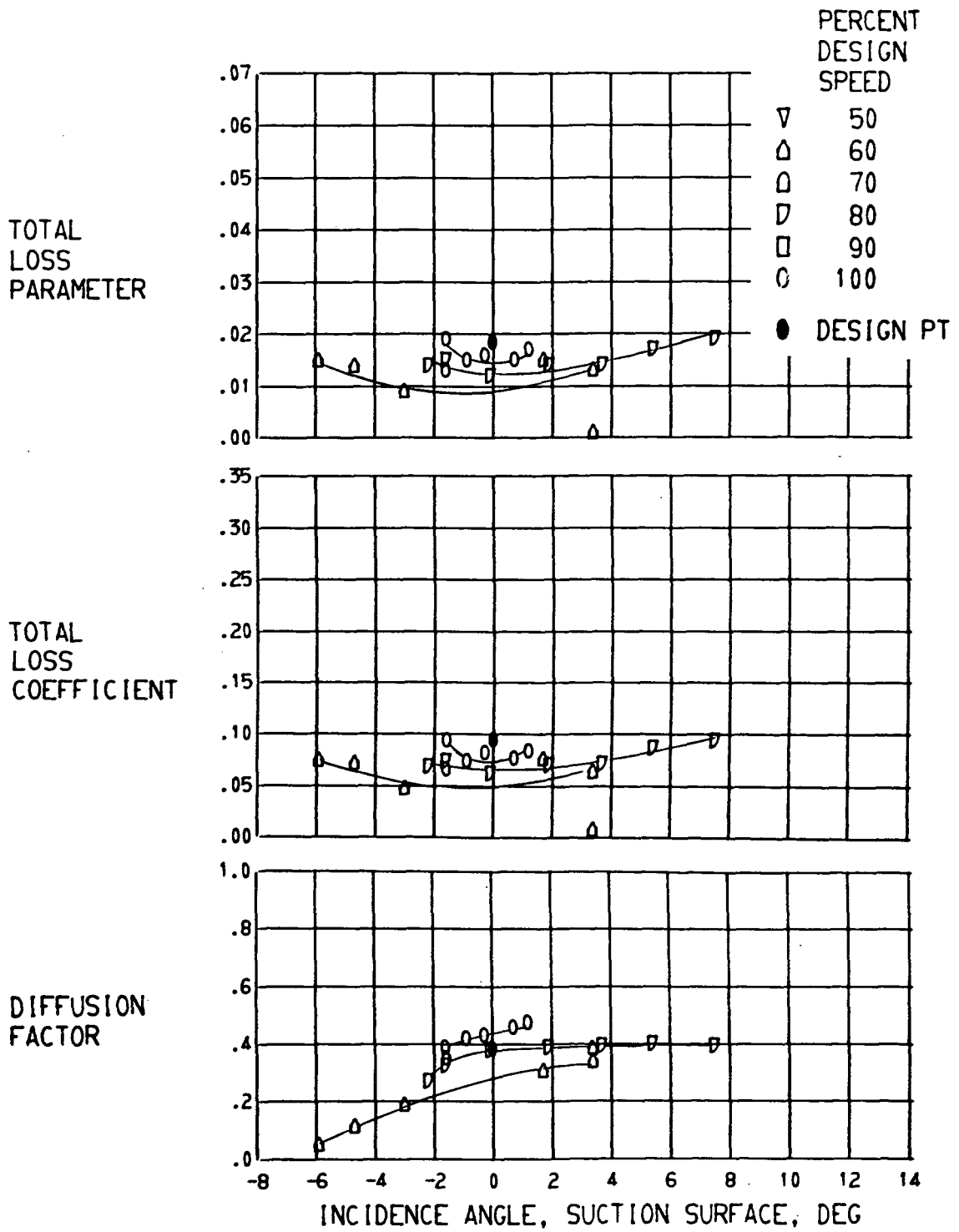

FIGURE 12. - BLADE ELEMENT PERFORMANCE FOR ROTOR 3.



(F) CONTINUED. 90.0 PERCENT SPAN.

FIGURE 12. - BLADE ELEMENT PERFORMANCE FOR ROTOR 3.



(F) CONCLUDED. 90.0 PERCENT SPAN.

FIGURE 12. - BLADE ELEMENT PERFORMANCE FOR ROTOR 3.

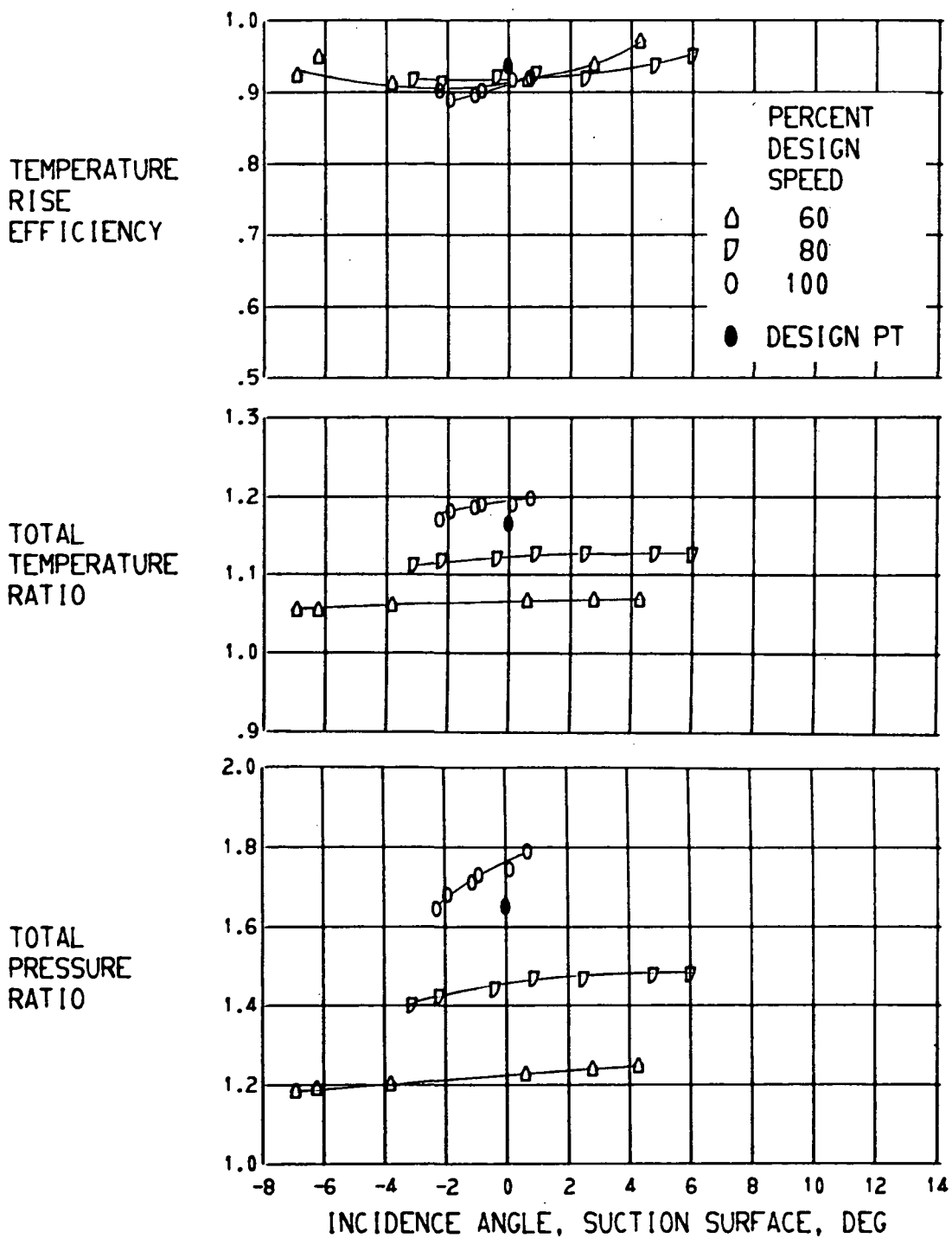

(G) 95.0 PERCENT SPAN.

FIGURE 12. - BLADE ELEMENT PERFORMANCE FOR ROTOR 3.

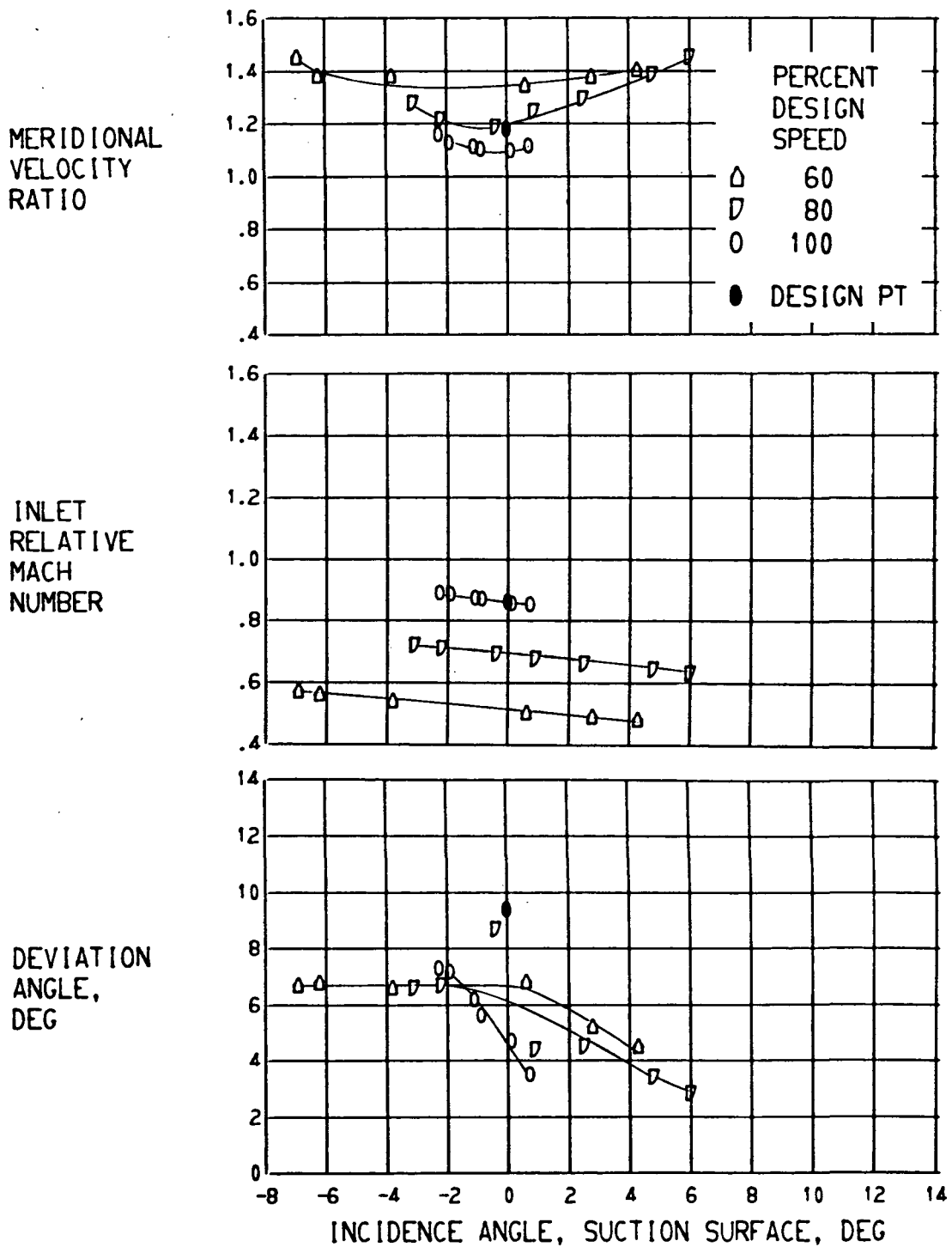

(G) CONTINUED. 95.0 PERCENT SPAN.

FIGURE 12. - BLADE ELEMENT PERFORMANCE FOR ROTOR 3.

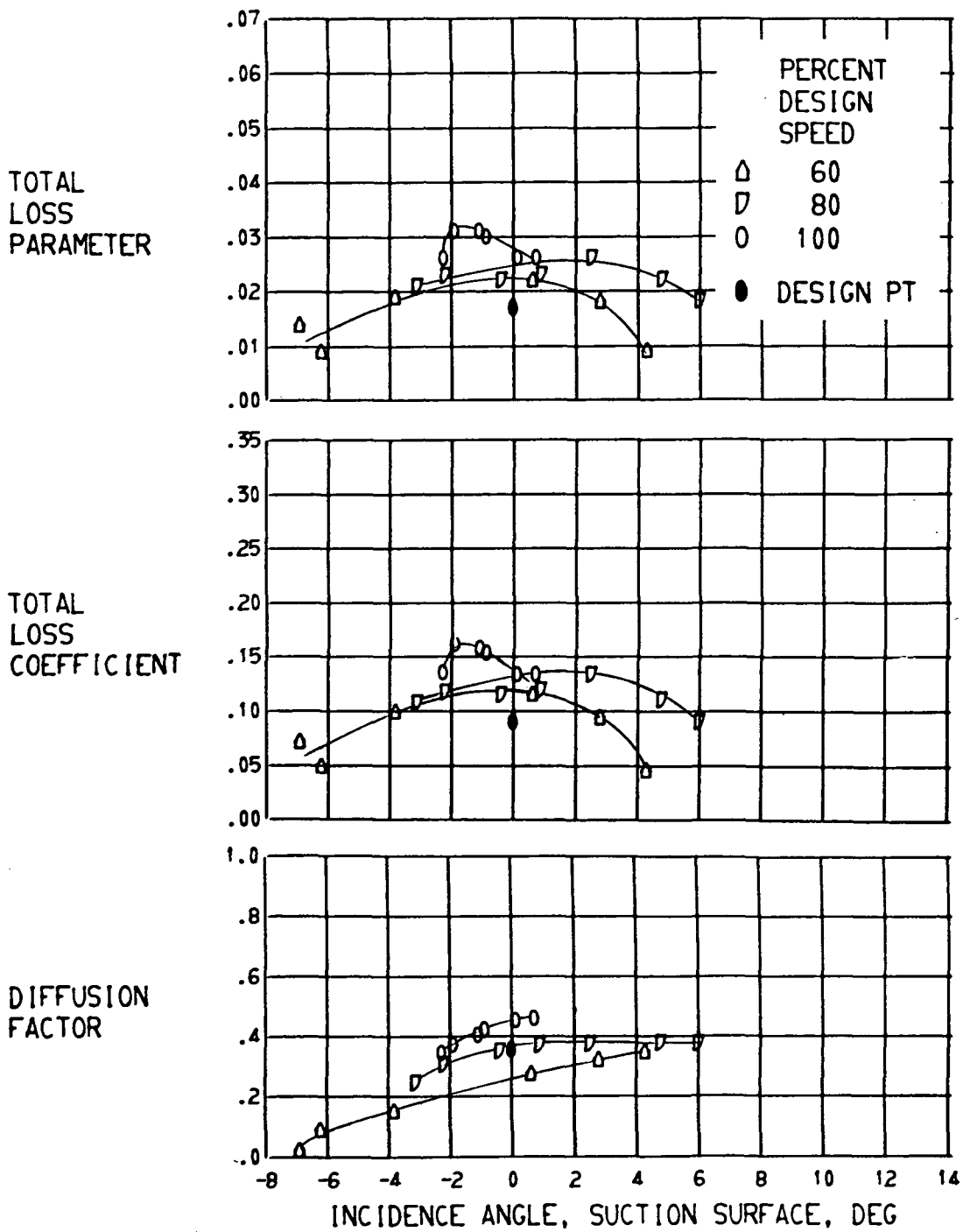

(G) CONCLUDED. 95.0 PERCENT SPAN.

FIGURE 12. - BLADE ELEMENT PERFORMANCE FOR ROTOR 3.



POSTMASTER: If Undeliverable (Section 156
Postal Manual) Do Not Return

"The aeronautical and space activities of the United States shall be conducted so as to contribute . . . to the expansion of human knowledge of phenomena in the atmosphere and space. The Administration shall provide for the widest practicable and appropriate dissemination of information concerning its activities and the results thereof."

— NATIONAL AERONAUTICS AND SPACE ACT OF 1958

NASA SCIENTIFIC AND TECHNICAL PUBLICATIONS

TECHNICAL REPORTS: Scientific and technical information considered important, complete, and a lasting contribution to existing knowledge.

TECHNICAL NOTES: Information less broad in scope but nevertheless of importance as a contribution to existing knowledge.

TECHNICAL MEMORANDUMS: Information receiving limited distribution because of preliminary data, security classification, or other reasons.

CONTRACTOR REPORTS: Scientific and technical information generated under a NASA contract or grant and considered an important contribution to existing knowledge.

TECHNICAL TRANSLATIONS: Information published in a foreign language considered to merit NASA distribution in English.

SPECIAL PUBLICATIONS: Information derived from or of value to NASA activities. Publications include conference proceedings, monographs, data compilations, handbooks, sourcebooks, and special bibliographies.

TECHNOLOGY UTILIZATION PUBLICATIONS: Information on technology used by NASA that may be of particular interest in commercial and other non-aerospace applications. Publications include Tech Briefs, Technology Utilization Reports and Technology Surveys.

Details on the availability of these publications may be obtained from:

**SCIENTIFIC AND TECHNICAL INFORMATION OFFICE
NATIONAL AERONAUTICS AND SPACE ADMINISTRATION
Washington, D.C. 20546**